

IS 456 : 2000
(Reaffirmed 2011)
(Reaffirmed 2016)
(Reaffirmed 2021)

भारतीय मानक
सामान्य एवं प्रबलित कंक्रीट — रीति संहिता
(चौथा पुनरीक्षण)

Indian Standard
PLAIN AND REINFORCED CONCRETE —
CODE OF PRACTICE
(*Fourth Revision*)

Fourteenth Reprint AUGUST 2014
(Including Amendments No. 1, 2, 3 & 4)

ICS 91.100.30

© BIS 2000

BUREAU OF INDIAN STANDARDS
MANAK BHAVAN, 9 BAHADUR SHAH ZAFAR MARG
NEW DELHI 110002

July 2000

Price Group 18 + Gr 3 + Gr 3

Indian Standard

PLAIN AND REINFORCED CONCRETE — CODE OF PRACTICE (Fourth Revision)

FOREWORD

This Indian Standard (Fourth Revision) was adopted by the Bureau of Indian Standards, after the draft finalized by the Cement and Concrete Sectional Committee had been approved by the Civil Engineering Division Council.

This standard was first published in 1953 under the title 'Code of practice for plain and reinforced concrete for general building construction' and subsequently revised in 1957. The code was further revised in 1964 and published under modified title 'Code of practice for plain and reinforced concrete', thus enlarging the scope of use of this code to structures other than general building construction also. The third revision was published in 1978, and it included limit state approach to design. This is the fourth revision of the standard. This revision was taken up with a view to keeping abreast with the rapid development in the field of concrete technology and to bring in further modifications/improvements in the light of experience gained while using the earlier version of the standard.

This revision incorporates a number of important changes. The major thrust in the revision is on the following lines:

- a) In recent years, durability of concrete structures have become the cause of concern to all concrete technologists. This has led to the need to codify the durability requirements world over. In this revision of the code, in order to introduce in-built protection from factors affecting a structure, earlier clause on durability has been elaborated and a detailed clause covering different aspects of design of durable structure has been incorporated.
- b) Sampling and acceptance criteria for concrete have been revised. With this revision acceptance criteria has been simplified in line with the provisions given in BS 5328 (Part 4):1990 'Concrete: Part 4 Specification for the procedures to be used in sampling, testing and assessing compliance of concrete'.

Some of the significant changes incorporated in Section 2 are as follows:

- a) All the three grades of ordinary Portland cement, namely 33 grade, 43 grade and 53 grade and sulphate resisting Portland cement have been included in the list of types of cement used (in addition to other types of cement).
- b) The permissible limits for solids in water have been modified keeping in view the durability requirements.
- c) The clause on admixtures has been modified in view of the availability of new types of admixtures including superplasticizers.
- d) In Table 2 'Grades of Concrete', grades higher than M 40 have been included.
- e) It has been recommended that minimum grade of concrete shall be not less than M 20 in reinforced concrete work (*see also 6.1.3*).
- f) The formula for estimation of modulus of elasticity of concrete has been revised.
- g) In the absence of proper correlation between compacting factor, vee-bee time and slump, workability has now been specified only in terms of slump in line with the provisions in BS 5328 (Parts 1 to 4).
- h) Durability clause has been enlarged to include detailed guidance concerning the factors affecting durability. The table on 'Environmental Exposure Conditions' has been modified to include 'very severe' and 'extreme' exposure conditions. This clause also covers requirements for shape and size of member, depth of concrete cover, concrete quality, requirement against exposure to aggressive chemical and sulphate attack, minimum cement requirement and maximum water cement ratio, limits of chloride content, alkali silica reaction, and importance of compaction, finishing and curing.
- j) A clause on 'Quality Assurance Measures' has been incorporated to give due emphasis to good practices of concreting.
- k) Proper limits have been introduced on the accuracy of measuring equipments to ensure accurate batching of concrete.

- m) The clause on 'Construction Joints' has been modified.
- n) The clause on 'Inspection' has been modified to give more emphasis on quality assurance.

The significant changes incorporated in Section 3 are as follows:

- a) Requirements for 'Fire Resistance' have been further detailed.
- b) The figure for estimation of modification factor for tension reinforcement used in calculation of basic values of span to effective depth to control the deflection of flexural member has been modified.
- c) Recommendations regarding effective length of cantilever have been added.
- d) Recommendations regarding deflection due to lateral loads have been added.
- e) Recommendations for adjustments of support moments in restrained slabs have been included.
- f) In the determination of effective length of compression members, stability index has been introduced to determine sway or no sway conditions.
- g) Recommendations have been made for lap length of hooks for bars in direct tension and flexural tension.
- h) Recommendations regarding strength of welds have been modified.
- j) Recommendations regarding cover to reinforcement have been modified. Cover has been specified based on durability requirements for different exposure conditions. The term 'nominal cover' has been introduced. The cover has now been specified based on durability requirement as well as for fire requirements.

The significant change incorporated in Section 4 is the modification of the clause on Walls. The modified clause includes design of walls against horizontal shear.

In Section 5 on limit state method a new clause has been added for calculation of enhanced shear strength of sections close to supports. Some modifications have also been made in the clause on Torsion. Formula for calculation of crack width has been added (separately given in Annex F).

Working stress method has now been given in Annex B so as to give greater emphasis to limit state design. In this Annex, modifications regarding torsion and enhanced shear strength on the same lines as in Section 5 have been made.

Whilst the common methods of design and construction have been covered in this code, special systems of design and construction of any plain or reinforced concrete structure not covered by this code may be permitted on production of satisfactory evidence regarding their adequacy and safety by analysis or test or both (*see 19*).

In this code it has been assumed that the design of plain and reinforced cement concrete work is entrusted to a qualified engineer and that the execution of cement concrete work is carried out under the direction of a qualified and experienced supervisor.

In the formulation of this standard, assistance has been derived from the following publications:

- BS 5328 : Part 1 : 1991 Concrete : Part 1 Guide to specifying concrete, British Standards Institution
- BS 5328 : Part 2 : 1991 Concrete : Part 2 Methods for specifying concrete mixes, British Standards Institution
- BS 5328 : Part 3 : 1990 Concrete : Part 3 Specification for the procedures to be used in producing and transporting concrete, British Standards Institution
- BS 5328 : Part 4 : 1990 Concrete : Part 4 Specification for the procedures to be used in sampling, testing and assessing compliance of concrete, British Standards Institution
- BS 8110 : Part 1 : 1985 Structural use of concrete : Part 1 Code of practice for design and construction, British Standards Institution
- BS 8110 : Part 2 : 1985 Structural use of concrete : Part 2 Code of practice for special circumstances, British Standards Institution
- ACI 319 : 1989 Building code requirements for reinforced concrete, American Concrete Institute
- AS 3600 : 1988 Concrete structures, Standards Association of Australia

DIN 1045 July 1988 Structural use of concrete, design and construction, Deutsches Institut für Normung E.V.
CEB-FIP Model code 1990, Comité Euro - International Du Béton

The composition of the technical committee responsible for the formulation of this standard is given in Annex H.

For the purpose of deciding whether a particular requirement of this standard is complied with, the final value, observed or calculated, expressing the result of a test or analysis shall be rounded off in accordance with IS 2 : 1960 'Rules for rounding off numerical values (*revised*)'. The number of significant places retained in the rounded off value should be the same as that of the specified value in this standard.

CONTENTS

	PAGE
SECTION 1 GENERAL	
1 SCOPE	11
2 REFERENCES	11
3 TERMINOLOGY	11
4 SYMBOLS	11
SECTION 2 MATERIALS, WORKMANSHIP, INSPECTION AND TESTING	
5 MATERIALS	13
5.1 Cement	13
5.2 Mineral Admixtures	13
5.3 Aggregates	14
5.4 Water	14
5.5 Admixtures	15
5.6 Reinforcement	15
5.7 Storage of Materials	15
6 CONCRETE	15
6.1 Grades	15
6.2 Properties of Concrete	15
7 WORKABILITY OF CONCRETE	17
8 DURABILITY OF CONCRETE	17
8.1 General	17
8.2 Requirements for Durability	18
9 CONCRETE MIX PROPORTIONING	22
9.1 Mix Proportion	22
9.2 Design Mix Concrete	22
9.3 Nominal Mix Concrete	23
10 PRODUCTION OF CONCRETE	23
10.1 Quality Assurance Measures	23
10.2 Batching	24
10.3 Mixing	24
11 FORMWORK	25
11.1 General	25
11.2 Cleaning and Treatment of Formwork	25
11.3 Stripping Time	25
12 ASSEMBLY OF REINFORCEMENT	25
13 TRANSPORTING, PLACING, COMPACTION AND CURING	26
13.1 Transporting and Handling	26
13.2 Placing	26
13.3 Compaction	26

	PAGE
13.4 Construction Joints and Cold Joints	27
13.5 Curing	27
13.6 Supervision	27
14 CONCRETING UNDER SPECIAL CONDITIONS	27
14.1 Work in Extreme Weather Conditions	27
14.2 Under-Water Concreting	27
15 SAMPLING AND STRENGTH OF DESIGNED CONCRETE MIX	29
15.1 General	29
15.2 Frequency of Sampling	29
15.3 Test Specimen	29
15.4 Test Results of Sample	29
16 ACCEPTANCE CRITERIA	29
17 INSPECTION AND TESTING OF STRUCTURE	30
SECTION 3 GENERAL DESIGN CONSIDERATION	
18 BASES FOR DESIGN	32
18.1 Aim of Design	32
18.2 Methods of Design	32
18.3 Durability, Workmanship and Materials	32
18.4 Design Process	32
19 LOADS AND FORCES	32
19.1 General	32
19.2 Dead Loads	32
19.3 Imposed Loads, Wind Loads and Snow Loads	32
19.4 Earthquake Forces	32
19.5 Shrinkage, Creep and Temperature Effects	32
19.6 Other Forces and Effects	33
19.7 Combination of Loads	33
19.8 Dead Load Counteracting Other Loads and Forces	33
19.9 Design Load	33
20 STABILITY OF THE STRUCTURE	33
20.1 Overturning	33
20.2 Sliding	33
20.3 Probable Variation in Dead Load	33
20.4 Moment Connection	33
20.5 Lateral Sway	33
21 FIRE RESISTANCE	33
22 ANALYSIS	34
22.1 General	34
22.2 Effective Span	34
22.3 Stiffness	35

	PAGE
22.4 Structural Frames	35
22.5 Moment and Shear Coefficients for Continuous Beams	35
22.6 Critical Sections for Moment and Shear	36
22.7 Redistribution of Moments	36
23 BEAMS	36
23.0 Effective Depth	36
23.1 T-Beams and L-Beams	36
23.2 Control of Deflection	37
23.3 Slenderness Limits for Beams to Ensure Lateral Stability	39
24 SOLID SLABS	39
24.1 General	39
24.2 Slabs Continuous Over Supports	39
24.3 Slabs Monolithic with Supports	39
24.4 Slabs Spanning in Two Directions at Right Angles	41
24.5 Loads on Supporting Beams	41
25 COMPRESSION MEMBERS	41
25.1 Definitions	41
25.2 Effective Length of Compression Members	42
25.3 Slenderness Limits for Columns	42
25.4 Minimum Eccentricity	42
26 REQUIREMENTS GOVERNING REINFORCEMENT AND DETAILING	42
26.1 General	42
26.2 Development of Stress in Reinforcement	42
26.3 Spacing of Reinforcement	45
26.4 Nominal Cover to Reinforcement	46
26.5 Requirements of Reinforcement for Structural Members	46
27 EXPANSION JOINTS	50

SECTION 4 SPECIAL DESIGN REQUIREMENTS FOR STRUCTURAL MEMBERS AND SYSTEMS

28 CONCRETE CORBELS	51
28.1 General	51
28.2 Design	51
29 DEEP BEAMS	51
29.1 General	51
29.2 Lever Arm	51
29.3 Reinforcement	51
30 RIBBED, HOLLOW BLOCK OR VOIDED SLAB	52
30.1 General	52
30.2 Analysis of Structure	52
30.3 Shear	52
30.4 Deflection	52

	PAGE
30.5 Size and Position of Ribs	52
30.6 Hollow Blocks and Formers	52
30.7 Arrangement of Reinforcement	53
30.8 Precast Joists and Hollow Filler Blocks	53
31 FLAT SLABS	53
31.1 General	53
31.2 Proportioning	53
31.3 Determination of Bending Moment	53
31.4 Direct Design Method	54
31.5 Equivalent Frame Method	56
31.6 Shear in Flat Slab	57
31.7 Slab Reinforcement	59
31.8 Openings in Flat Slabs	61
32 WALLS	61
32.1 General	61
32.2 Empirical Design Method for Walls Subjected to Inplane Vertical Loads	61
32.3 Walls Subjected to Combined Horizontal and Vertical Forces	62
32.4 Design for Horizontal Shear	62
32.5 Minimum Requirements for Reinforcement in Walls	62
33 STAIRS	63
33.1 Effective Span of Stairs	63
33.2 Distribution of Loading on Stairs	63
33.3 Depth of Section	63
34 FOOTINGS	63
34.1 General	63
34.2 Moments and Forces	64
34.3 Tensile Reinforcement	65
34.4 Transfer of Load at the Base of Column	65
34.5 Nominal Reinforcement	66
SECTION 5 STRUCTURAL DESIGN (LIMIT STATE METHOD)	
35 SAFETY AND SERVICEABILITY REQUIREMENTS	67
35.1 General	67
35.2 Limit State of Collapse	67
35.3 Limit States of Serviceability	67
35.4 Other Limit States	67
36 CHARACTERISTIC AND DESIGN VALUES AND PARTIAL SAFETY FACTORS	67
36.1 Characteristic Strength of Materials	67
36.2 Characteristic Loads	67
36.3 Design Values	68
36.4 Partial Safety Factors	68
37 ANALYSIS	68
37.1 Analysis of Structure	68

	PAGE
38 LIMIT STATE OF COLLAPSE : FLEXURE	69
38.1 Assumptions	69
39 LIMIT STATE OF COLLAPSE: COMPRESSION	70
39.1 Assumptions	70
39.2 Minimum Eccentricity	71
39.3 Short Axially Loaded Members in Compression	71
39.4 Compression Members with Helical Reinforcement	71
39.5 Members Subjected to Combined Axial Load and Uniaxial Bending	71
39.6 Members Subjected to Combined Axial Load and Biaxial Bending	71
39.7 Slender Compression Members	71
40 LIMIT STATE OF COLLAPSE : SHEAR	72
40.1 Nominal Shear Stress	72
40.2 Design Shear Strength of Concrete	72
40.3 Minimum Shear Reinforcement	72
40.4 Design of Shear Reinforcement	72
40.5 Enhanced Shear Strength of Sections Close to Supports	74
41 LIMIT STATE OF COLLAPSE : TORSION	74
41.1 General	74
41.2 Critical Section	75
41.3 Shear and Torsion	75
41.4 Reinforcement in Members Subjected to Torsion	75
42 LIMIT STATE OF SERVICEABILITY: DEFLECTION	75
42.1 Flexural Members	75
43 LIMIT STATE OF SERVICEABILITY: CRACKING	76
43.1 Flexural Members	76
43.2 Compression Members	76
ANNEX A LIST OF REFERRED INDIAN STANDARDS	77
ANNEX B STRUCTURAL DESIGN (WORKING STRESS METHOD)	80
B-1 GENERAL	80
B-1.1 General Design Requirements	80
B-1.2 Redistribution of Moments	80
B-1.3 Assumptions for Design of Members	80
B-2 PERMISSIBLE STRESSES	80
B-2.1 Permissible Stresses in Concrete	80
B-2.2 Permissible Stresses in Steel Reinforcement	80
B-2.3 Increase in Permissible Stresses	80
B-3 PERMISSIBLE LOADS IN COMPRESSION MEMBERS	81
B-3.1 Pedestals and Short Columns with Lateral Ties	81
B-3.2 Short Columns with Helical Reinforcement	81
B-3.3 Long Columns	81
B-3.4 Composite Columns	81

	PAGE
B-4 MEMBERS SUBJECTED TO COMBINED AXIAL LOAD AND BENDING	83
B-4.1 Design Based on Uncracked Section	83
B-4.2 Design Based on Cracked Section	83
B-4.3 Members Subjected to Combined Direct Load and Flexure	83
B-5 SHEAR	83
B-5.1 Nominal Shear Stress	83
B-5.2 Design Shear Strength of Concrete	84
B-5.3 Minimum Shear Reinforcement	85
B-5.4 Design of Shear Reinforcement	85
B-5.5 Enhanced Shear Strength of Sections Close to Supports	85
B-6 TORSION	86
B-6.1 General	86
B-6.2 Critical Section	86
B-6.3 Shear and Torsion	86
B-6.4 Reinforcement in Members Subjected to Torsion	86
ANNEX C CALCULATION OF DEFLECTION	88
C-1 TOTAL DEFLECTION	88
C-2 SHORT-TERM DEFLECTION	88
C-3 DEFLECTION DUE TO SHRINKAGE	88
C-4 DEFLECTION DUE TO CREEP	89
ANNEX D SLABS SPANNING IN TWO DIRECTIONS	90
D-1 RESTRAINED SLABS	90
D-2 SIMPLY SUPPORTED SLABS	90
ANNEX E EFFECTIVE LENGTH OF COLUMNS	92
ANNEX F CALCULATION OF CRACK WIDTH	95
ANNEX G MOMENTS OF RESISTANCE FOR RECTANGULAR AND T-SECTIONS	96
G-1 RECTANGULAR SECTIONS	96
G-1.1 Sections without Compression Reinforcement	96
G-1.2 Sections with Compression Reinforcement	96
G-2 FLANGED SECTION	96
ANNEX H COMMITTEE COMPOSITION	98

SECTION 1 GENERAL

1 SCOPE

1.1 This standard deals with the general structural use of plain and reinforced concrete.

1.1.1 For the purpose of this standard, plain concrete structures are those where reinforcement, if provided is ignored for determination of strength of the structure.

1.2 Special requirements of structures, such as shells, folded plates, arches, bridges, chimneys, blast resistant structures, hydraulic structures, liquid retaining structures and earthquake resistant structures, covered in respective standards have not been covered in this standard; these standards shall be used in conjunction with this standard.

2 REFERENCES

The Indian Standards listed in Annex A contain provisions which through reference in this text, constitute provisions of this standard. At the time of publication, the editions indicated were valid. All standards are subject to revision and parties to agreements based on this standard are encouraged to investigate the possibility of applying the most recent editions of the standards indicated in Annex A.

3 TERMINOLOGY

For the purpose of this standard, the definitions given in IS 4845 and IS 6461 (Parts 1 to 12) shall generally apply.

4 SYMBOLS

For the purpose of this standard, the following letter symbols shall have the meaning indicated against each; where other symbols are used, they are explained at the appropriate place:

A	– Area
b	– Breadth of beam, or shorter dimension of a rectangular column
b_{ef}	– Effective width of slab
b_f	– Effective width of flange
b_w	– Breadth of web or rib
D	– Overall depth of beam or slab or diameter of column; dimension of a rectangular column in the direction under consideration
D_f	– Thickness of flange
DL	– Dead load
d	– Effective depth of beam or slab
d'	– Depth of compression reinforcement from the highly compressed face
E_c	– Modulus of elasticity of concrete

EL	– Earthquake load
E_s	– Modulus of elasticity of steel
e	– Eccentricity
f_{ck}	– Characteristic cube compressive strength of concrete
f_{cr}	– Modulus of rupture of concrete (flexural tensile strength)
f_{ct}	– Splitting tensile strength of concrete
f_d	– Design strength
f_y	– Characteristic strength of steel
H_w	– Unsupported height of wall
H_{we}	– Effective height of wall
I_{ef}	– Effective moment of inertia
I_{gr}	– Moment of inertia of the gross section excluding reinforcement
I_r	– Moment of inertia of cracked section
K	– Stiffness of member
k	– Constant or coefficient or factor
L_d	– Development length
LL	– Live load or imposed load
L_w	– Horizontal distance between centres of lateral restraint
l	– Length of a column or beam between adequate lateral restraints or the unsupported length of a column
l_{ef}	– Effective span of beam or slab or effective length of column
l_{ex}	– Effective length about $x-x$ axis
l_{ey}	– Effective length about $y-y$ axis
l_n	– Clear span, face-to-face of supports
l'_n	– l'_n for shorter of the two spans at right angles
l_x	– Length of shorter side of slab
l_y	– Length of longer side of slab
l_0	– Distance between points of zero moments in a beam
l_1	– Span in the direction in which moments are determined, centre to centre of supports
l_2	– Span transverse to l_1 , centre to centre of supports
l'_2	– l'_2 for the shorter of the continuous spans
M	– Bending moment
m	– Modular ratio
n	– Number of samples
P	– Axial load on a compression member
q_0	– Calculated maximum bearing pressure

q_0	- Calculated maximum bearing pressure of soil	γ_m	- Partial safety factor for material
r	- Radius	δ_m	- Percentage reduction in moment
s	- Spacing of stirrups or standard deviation	ϵ_{cc}	- Creep strain of concrete
T	- Torsional moment	σ_{cbc}	- Permissible stress in concrete in bending compression
t	- Wall thickness	σ_{cc}	- Permissible stress in concrete in direct compression
V	- Shear force	σ_{mc}	- Permissible stress in metal in direct compression
W	- Total load	σ_{sc}	- Permissible stress in steel in compression
WL	- Wind load	σ_{st}	- Permissible stress in steel in tension
w	- Distributed load per unit area	σ_{sv}	- Permissible tensile stress in shear reinforcement
w_d	- Distributed dead load per unit area	τ_{bd}	- Design bond stress
w_l	- Distributed imposed load per unit area	τ_c	- Shear stress in concrete
x	- Depth of neutral axis	$\tau_{c,max}$	- Maximum shear stress in concrete with shear reinforcement
Z	- Modulus of section	τ_v	- Nominal shear stress
z	- Lever arm	ϕ	- Diameter of bar
α, β	- Angle or ratio		
γ_r	- Partial safety factor for load		

SECTION 2 MATERIALS, WORKMANSHIP, INSPECTION AND TESTING

5 MATERIALS

5.1 Cement

The cement used shall be any of the following and the type selected should be appropriate for the intended use:

- a) 33 Grade ordinary Portland cement conforming to IS 269
- b) 43 Grade ordinary Portland cement conforming to IS 8112
- c) 53 Grade ordinary Portland cement conforming to IS 12269
- d) Rapid hardening Portland cement conforming to IS 8041
- e) Portland slag cement conforming to IS 455
- f) Portland pozzolana cement (fly ash based) conforming to IS 1489 (Part 1)
- g) Portland pozzolana cement (calcined clay based) conforming to IS 1489 (Part 2)
- h) Hydrophobic cement conforming to IS 8043
- j) Low heat Portland cement conforming to IS 12600
- k) Sulphate resisting Portland cement conforming to IS 12330

Other combinations of Portland cement with mineral admixtures (*see* 5.2) of quality conforming with relevant Indian Standards laid down may also be used in the manufacture of concrete provided that there are satisfactory data on their suitability, such as performance test on concrete containing them.

5.1.1 Low heat Portland cement conforming to IS 12600 shall be used with adequate precautions with regard to removal of formwork, etc.

5.1.2 High alumina cement conforming to IS 6452 or supersulphated cement conforming to IS 6909 may be used only under special circumstances with the prior approval of the engineer-in-charge. Specialist literature may be consulted for guidance regarding the use of these types of cements.

5.1.3 The attention of the engineers-in-charge and users of cement is drawn to the fact that quality of various cements mentioned in 5.1 is to be determined on the basis of its conformity to the performance characteristics given in the respective Indian Standard Specification for that cement. Any trade-mark or any trade name indicating any special features not covered in the standard or any qualification or other special performance characteristics sometimes claimed/indicated on the bags or containers or in advertisements alongside the 'Statutory Quality Marking' or otherwise

have no relation whatsoever with the characteristics guaranteed by the Quality Marking as relevant to that cement. Consumers are, therefore, advised to go by the characteristics as given in the corresponding Indian Standard Specification or seek specialist advise to avoid any problem in concrete making and construction.

5.2 Mineral Admixtures

5.2.1 Pozzolanas

Pozzolanic materials conforming to relevant Indian Standards may be used with the permission of the engineer-in-charge, provided uniform blending with cement is ensured.

5.2.1.1 Fly ash (pulverized fuel ash)

Fly ash conforming to Grade 1 of IS 3812 may be used as part replacement of ordinary Portland cement provided uniform blending with cement is ensured.

5.2.1.2 Silica fume

Silica fume conforming to a standard approved by the deciding authority may be used as part replacement of cement provided uniform blending with the cement is ensured.

NOTE—The silica fume (very fine non-crystalline silicon dioxide) is a by-product of the manufacture of silicon, ferrosilicon or the like, from quartz and carbon in electric arc furnace. It is usually used in proportion of 5 to 10 percent of the cement content of a mix.

5.2.1.3 Rice husk ash

Rice husk ash giving required performance and uniformity characteristics may be used with the approval of the deciding authority.

NOTE—Rice husk ash is produced by burning rice husk and contain large proportion of silica. To achieve amorphous state, rice husk may be burnt at controlled temperature. It is necessary to evaluate the product from a particular source for performance and uniformity since it can range from being as deleterious as silt when incorporated in concrete. Water demand and drying shrinkage should be studied before using rice husk.

5.2.1.4 Metakaoline

Metakaoline having fineness between 700 to 900 m²/kg may be used as pozzolanic material in concrete.

NOTE—Metakaoline is obtained by calcination of pure or refined kaolintic clay at a temperature between 650°C and 850°C, followed by grinding to achieve a fineness of 700 to 900 m²/kg. The resulting material has high pozzolanicity.

5.2.2 Ground Granulated Blast Furnace Slag

Ground granulated blast furnace slag obtained by grinding granulated blast furnace slag conforming to IS 12089 may be used as part replacement of ordinary

Portland cements provided uniform blending with cement is ensured.

5.3 Aggregates

Aggregates shall comply with the requirements of IS 383. As far as possible preference shall be given to natural aggregates.

5.3.1 Other types of aggregates such as slag and crushed overburnt brick or tile, which may be found suitable with regard to strength, durability of concrete and freedom from harmful effects may be used for plain concrete members, but such aggregates should not contain more than 0.5 percent of sulphates as SO_3 and should not absorb more than 10 percent of their own mass of water.

5.3.2 Heavy weight aggregates or light weight aggregates such as bloated clay aggregates and sintered fly ash aggregates may also be used provided the engineer-in-charge is satisfied with the data on the properties of concrete made with them.

NOTE—Some of the provisions of the code would require modification when these aggregates are used; specialist literature may be consulted for guidance.

5.3.3 Size of Aggregate

The nominal maximum size of coarse aggregate should be as large as possible within the limits specified but in no case greater than one-fourth of the minimum thickness of the member, provided that the concrete can be placed without difficulty so as to surround all reinforcement thoroughly and fill the corners of the form. For most work, 20 mm aggregate is suitable. Where there is no restriction to the flow of concrete into sections, 40 mm or larger size may be permitted. In concrete elements with thin sections, closely spaced reinforcement or small cover, consideration should be given to the use of 10 mm nominal maximum size.

Plums above 160 mm and up to any reasonable size may be used in plain concrete work up to a maximum limit of 20 percent by volume of concrete when specifically permitted by the engineer-in-charge. The plums shall be distributed evenly and shall be not closer than 150 mm from the surface.

5.3.3.1 For heavily reinforced concrete members as in the case of ribs of main beams, the nominal maximum size of the aggregate should usually be restricted to 5 mm less than the minimum clear distance between the main bars or 5 mm less than the minimum cover to the reinforcement whichever is smaller.

5.3.4 Coarse and fine aggregate shall be batched separately. All-in-aggregate may be used only where specifically permitted by the engineer-in-charge.

5.4 Water

Water used for mixing and curing shall be clean and

free from injurious amounts of oils, acids, alkalis, salts, sugar, organic materials or other substances that may be deleterious to concrete or steel.

Potable water is generally considered satisfactory for mixing concrete. As a guide the following concentrations represent the maximum permissible values:

- a) To neutralize 100 ml sample of water, using phenolphthalein as an indicator, it should not require more than 5 ml of 0.02 normal NaOH. The details of test are given in 8.1 of IS 3025 (Part 22).
- b) To neutralize 100 ml sample of water, using mixed indicator, it should not require more than 25 ml of 0.02 normal H_2SO_4 . The details of test shall be as given in 8 of IS 3025 (Part 23).
- c) Permissible limits for solids shall be as given in Table I.

5.4.1 In case of doubt regarding development of strength, the suitability of water for making concrete shall be ascertained by the compressive strength and initial setting time tests specified in 5.4.1.2 and 5.4.1.3.

5.4.1.1 The sample of water taken for testing shall represent the water proposed to be used for concreting, due account being paid to seasonal variation. The sample shall not receive any treatment before testing other than that envisaged in the regular supply of water proposed for use in concrete. The sample shall be stored in a clean container previously rinsed out with similar water.

5.4.1.2 Average 28 days compressive strength of at least three 150 mm concrete cubes prepared with water proposed to be used shall not be less than 90 percent of the average of strength of three similar concrete cubes prepared with distilled water. The cubes shall be prepared, cured and tested in accordance with the requirements of IS 516.

5.4.1.3 The initial setting time of test block made with the appropriate cement and the water proposed to be used shall not be less than 30 min and shall not differ by ± 30 min from the initial setting time of control test block prepared with the same cement and distilled water. The test blocks shall be prepared and tested in accordance with the requirements of IS 4031 (Part 5).

5.4.2 The pH value of water shall be not less than 6.

5.4.3 Sea Water

Mixing or curing of concrete with sea water is not recommended because of presence of harmful salts in sea water. Under unavoidable circumstances sea water may be used for mixing or curing in plain concrete with no embedded steel after having given due consideration to possible disadvantages and precautions including use of appropriate cement system.

Table 1 Permissible Limit for Solids
(Clause 5.4)

Sl No.		Tested as per	Permissible Limit, Max
i)	Organic	IS 3025 (Part 18)	200 mg/l
ii)	Inorganic	IS 3025 (Part 18)	3 000 mg/l
iii)	Sulphates (as SO ₃)	IS 3025 (Part 24)	400 mg/l
iv)	Chlorides (as Cl)	IS 3025 (Part 32)	2 000 mg/l for concrete not containing embedded steel and 500 mg/l for reinforced concrete work
v)	Suspended matter	IS 3025 (Part 17)	2 000 mg/l

5.4.4 Water found satisfactory for mixing is also suitable for curing concrete. However, water used for curing should not produce any objectionable stain or unsightly deposit on the concrete surface. The presence of tannic acid or iron compounds is objectionable.

5.5 Admixtures

5.5.1 Admixture, if used shall comply with IS 9103. Previous experience with and data on such materials should be considered in relation to the likely standards of supervision and workmanship to the work being specified.

5.5.2 Admixtures should not impair durability of concrete nor combine with the constituent to form harmful compounds nor increase the risk of corrosion of reinforcement.

5.5.3 The workability, compressive strength and the slump loss of concrete with and without the use of admixtures shall be established during the trial mixes before use of admixtures.

5.5.4 The relative density of liquid admixtures shall be checked for each drum containing admixtures and compared with the specified value before acceptance.

5.5.5 The chloride content of admixtures shall be independently tested for each batch before acceptance.

5.5.6 If two or more admixtures are used simultaneously in the same concrete mix, data should be obtained to assess their interaction and to ensure their compatibility.

5.6 Reinforcement

The reinforcement shall be any of the following:

- Mild steel and medium tensile steel bars conforming to IS 432 (Part 1).
- High strength deformed steel bars conforming to IS 1786.
- Hard-drawn steel wire fabric conforming to IS 1566.
- Structural steel conforming to Grade A of IS 2062.

5.6.1 All reinforcement shall be free from loose mill scales, loose rust and coats of paints, oil, mud or any other substances which may destroy or reduce bond. Sand blasting or other treatment is recommended to clean reinforcement.

5.6.2 Special precautions like coating of reinforcement may be required for reinforced concrete elements in exceptional cases and for rehabilitation of structures. Specialist literature may be referred to in such cases.

5.6.3 The modulus of elasticity of steel shall be taken as 200 kN/mm². The characteristic yield strength of different steel shall be assumed as the minimum yield stress/0.2 percent proof stress specified in the relevant Indian Standard.

5.7 Storage of Materials

Storage of materials shall be as described in IS 4082.

6 CONCRETE

6.1 Grades

The concrete shall be in grades designated as per Table 2.

6.1.1 The characteristic strength is defined as the strength of material below which not more than 5 percent of the test results are expected to fall.

6.1.2 The minimum grade of concrete for plain and reinforced concrete shall be as per Table 5.

6.1.3 Concrete of grades lower than those given in Table 5 may be used for plain concrete constructions, lean concrete, simple foundations, foundation for masonry walls and other simple or temporary reinforced concrete construction.

6.2 Properties of Concrete

6.2.1 Increase of Strength with Age

There is normally a gain of strength beyond 28 days. The quantum of increase depends upon the grade and type of cement, curing and environmental conditions, etc. The design should be based on 28 days characteristic strength of concrete unless there is a evidence to

Table 2 Grades of Concrete
(Clause 6.1, 9.2.2, 15.1.1 and 36.1)

Group	Grade Designation	Specified Characteristic Compressive Strength of 150 mm Cube at 28 Days in N/mm ²
(1)	(2)	(3)
Ordinary Concrete	M 10	10
	M 15	15
	M 20	20
Standard Concrete	M 25	25
	M 30	30
	M 35	35
	M 40	40
	M 45	45
	M 50	50
High Strength Concrete	M 55	55
	M 60	60
	M 65	65
	M 70	70
	M 75	75
	M 80	80

NOTES

1 In the designation of concrete mix M refers to the mix and the number to the specified compressive strength of 150 mm size cube at 28 days, expressed in N/mm².

2 For concrete of compressive strength greater than M 55, design parameters given in the standard may not be applicable and the values may be obtained from specialized literatures and experimental results.

justify a higher strength for a particular structure due to age.

6.2.1.1 For concrete of grade M 30 and above, the rate of increase of compressive strength with age shall be based on actual investigations.

6.2.1.2 Where members are subjected to lower direct load during construction, they should be checked for stresses resulting from combination of direct load and bending during construction.

6.2.2 Tensile Strength of Concrete

The flexural and splitting tensile strengths shall be obtained as described in IS 516 and IS 5816 respectively. When the designer wishes to use an estimate of the tensile strength from the compressive strength, the following formula may be used:

$$\text{Flexural strength, } f_{cr} = 0.7 \sqrt{f_{ck}} \text{ N/mm}^2$$

where f_{ck} is the characteristic cube compressive strength of concrete in N/mm².

6.2.3 Elastic Deformation

The modulus of elasticity is primarily influenced by the elastic properties of the aggregate and to a lesser extent by the conditions of curing and age of the concrete, the mix proportions and the type of cement. The modulus of elasticity is normally related to the compressive strength of concrete.

6.2.3.1 The modulus of elasticity of concrete can be assumed as follows:

$$E_c = 5000 \sqrt{f_{ck}}$$

where

E_c is the short term static modulus of elasticity in N/mm².

Actual measured values may differ by ± 20 percent from the values obtained from the above expression.

6.2.4 Shrinkage

The total shrinkage of concrete depends upon the constituents of concrete, size of the member and environmental conditions. For a given humidity and temperature, the total shrinkage of concrete is most influenced by the total amount of water present in the concrete at the time of mixing and, to a lesser extent, by the cement content.

6.2.4.1 In the absence of test data, the approximate value of the total shrinkage strain for design may be taken as 0.0003 (for more information, see IS 1343).

6.2.5 Creep of Concrete

Creep of concrete depends, in addition to the factors listed in 6.2.4, on the stress in the concrete, age at loading and the duration of loading. As long as the stress in concrete does not exceed one-third of its characteristic compressive strength, creep may be assumed to be proportional to the stress.

6.2.5.1 In the absence of experimental data and detailed information on the effect of the variables, the ultimate creep strain may be estimated from the following values of creep coefficient (that is, ultimate creep strain/elastic strain at the age of loading); for long span structure, it is advisable to determine actual creep strain, likely to take place:

Age at Loading	Creep Coefficient
7 days	2.2
28 days	1.6
1 year	1.1

NOTE—The ultimate creep strain, estimated as described above does not include the elastic strain.

6.2.6 Thermal Expansion

The coefficient of thermal expansion depends on nature of cement, the aggregate, the cement content, the relative humidity and the size of sections. The value of coefficient of thermal expansion for concrete with different aggregates may be taken as below:

Type of Aggregate	Coefficient of Thermal Expansion for Concrete/°C
Quartzite	1.2 to 1.3×10^{-5}
Sandstone	0.9 to 1.2×10^{-5}
Granite	0.7 to 0.95×10^{-5}
Basalt	0.8 to 0.95×10^{-5}
Limestone	0.6 to 0.9×10^{-5}

7 WORKABILITY OF CONCRETE

7.1 The concrete mix proportions chosen should be such that the concrete is of adequate workability for the placing conditions of the concrete and can properly

be compacted with the means available. Suggested ranges of workability of concrete measured in accordance with IS 1199 are given below:

Placing Conditions (1)	Degree of Workability (2)	Slump (mm) (3)
Blinding concrete; Shallow sections; Pavements using pavers	Very low	See 7.1.1
Mass concrete; Lightly reinforced sections in slabs, beams, walls, columns; Floors; Hand placed pavements; Canal lining; Strip footings	Low	25-75
Heavily reinforced sections in slabs, beams, walls, columns; Slipform work; Pumped concrete	Medium	50-100 75-100
Trench fill; <i>In-situ</i> piling	High	100-150
Tremie concrete	Very high	See 7.1.2

NOTE—For most of the placing conditions, internal vibrators (needle vibrators) are suitable. The diameter of the needle shall be determined based on the density and spacing of reinforcement bars and thickness of sections. For tremie concrete, vibrators are not required to be used (see also 13.3).

7.1.1 In the 'very low' category of workability where strict control is necessary, for example pavement quality concrete, measurement of workability by determination of compacting factor will be more appropriate than slump (see IS 1199) and a value of compacting factor of 0.75 to 0.80 is suggested.

7.1.2 In the 'very high' category of workability, measurement of workability by determination of flow will be appropriate (see IS 9103).

8 DURABILITY OF CONCRETE

8.1 General

A durable concrete is one that performs satisfactorily in the working environment during its anticipated exposure conditions during service. The materials and mix proportions specified and used should be such as to maintain its integrity and, if applicable, to protect embedded metal from corrosion.

8.1.1 One of the main characteristics influencing the durability of concrete is its permeability to the ingress of water, oxygen, carbon dioxide, chloride, sulphate and other potentially deleterious substances. Impermeability is governed by the constituents and workmanship used in making the concrete. With normal-weight aggregates

a suitably low permeability is achieved by having an adequate cement content, sufficiently low free water/cement ratio, by ensuring complete compaction of the concrete, and by adequate curing.

The factors influencing durability include:

- the environment;
- the cover to embedded steel;
- the type and quality of constituent materials;
- the cement content and water/cement ratio of the concrete;
- workmanship, to obtain full compaction and efficient curing; and
- the shape and size of the member.

The degree of exposure anticipated for the concrete during its service life together with other relevant factors relating to mix composition, workmanship, design and detailing should be considered. The concrete mix to provide adequate durability under these conditions should be chosen taking account of the accuracy of current testing regimes for control and compliance as described in this standard.

8.2 Requirements for Durability

8.2.1 Shape and Size of Member

The shape or design details of exposed structures should be such as to promote good drainage of water and to avoid standing pools and rundown of water. Care should also be taken to minimize any cracks that may collect or transmit water. Adequate curing is essential to avoid the harmful effects of early loss of moisture (see 13.5). Member profiles and their intersections with other members shall be designed and detailed in a way to ensure easy flow of concrete and proper compaction during concreting.

Concrete is more vulnerable to deterioration due to chemical or climatic attack when it is in thin sections, in sections under hydrostatic pressure from one side only, in partially immersed sections and at corners and edges of elements. The life of the structure can be lengthened by providing extra cover to steel, by chamfering the corners or by using circular cross-sections or by using surface coatings which prevent or reduce the ingress of water, carbon dioxide or aggressive chemicals.

8.2.2 Exposure Conditions

8.2.2.1 General environment

The general environment to which the concrete will be exposed during its working life is classified into five levels of severity, that is, mild, moderate, severe, very severe and extreme as described in Table 3.

Table 3 Environmental Exposure Conditions
(Clauses 8.2.2.1 and 35.3.2)

Sl No. (1)	Environment (2)	Exposure Conditions (3)
i)	Mild	Concrete surfaces protected against weather or aggressive conditions, except those situated in coastal area.
ii)	Moderate	Concrete surfaces sheltered from severe rain or freezing whilst wet Concrete exposed to condensation and rain Concrete continuously under water Concrete in contact or buried under non-aggressive soil/ground water Concrete surfaces sheltered from saturated salt air in coastal area
iii)	Severe	Concrete surfaces exposed to severe rain, alternate wetting and drying or occasional freezing whilst wet or severe condensation. Concrete completely immersed in sea water
iv)	Very severe	Concrete exposed to coastal environment Concrete surfaces exposed to sea water spray, corrosive fumes or severe freezing conditions whilst wet Concrete in contact with or buried under aggressive sub-soil/ground water
v)	Extreme	Surface of members in tidal zone Members in direct contact with liquid/solid aggressive chemicals

8.2.2.2 Abrasive.

Specialist literatures may be referred to for durability requirements of concrete surfaces exposed to abrasive action, for example, in case of machinery and metal tyres.

8.2.2.3 Freezing and thawing

Where freezing and thawing actions under wet conditions exist, enhanced durability can be obtained by the use of suitable air entraining admixtures. When concrete lower than grade M 50 is used under these conditions, the mean total air content by volume of the fresh concrete at the time of delivery into the construction should be:

Nominal Maximum Size Aggregate (mm)	Entrained Air Percentage
20	5 ± 1
40	4 ± 1

Since air entrainment reduces the strength, suitable adjustments may be made in the mix design for achieving required strength.

8.2.2.4 Exposure to sulphate attack

Table 4 gives recommendations for the type of cement, maximum free water/cement ratio and minimum cement content, which are required at different sulphate concentrations in near-neutral ground water having pH of 6 to 9.

For the very high sulphate concentrations in Class 5 conditions, some form of lining such as polyethylene or polychloroprene sheet; or surface coating based on asphalt, chlorinated rubber, epoxy; or polyurethane materials should also be used to prevent access by the sulphate solution.

8.2.3 Requirement of Concrete Cover

8.2.3.1 The protection of the steel in concrete against corrosion depends upon an adequate thickness of good quality concrete.

8.2.3.2 The nominal cover to the reinforcement shall be provided as per 26.4.

8.2.4 Concrete Mix Proportions

8.2.4.1 General

The free water-cement ratio is an important factor in governing the durability of concrete and should always be the lowest value. Appropriate values for minimum cement content and the maximum free water-cement ratio are given in Table 5 for different exposure conditions. The minimum cement content and maximum water-cement ratio apply to 20 mm nominal maximum size aggregate. For other sizes of aggregate they should be changed as given in Table 6.

8.2.4.2 Maximum cement content

Cement content not including fly ash and ground granulated blast furnace slag in excess of 450 kg/m³ should not be used unless special consideration has

been given in design to the increased risk of cracking due to drying shrinkage in thin sections, or to early thermal cracking and to the increased risk of damage due to alkali silica reactions.

Table 4 Requirements for Concrete Exposed to Sulphate Attack

(Clauses 8.2.2.4 and 9.1.2)

Sl No.	Class	Concentration of Sulphates, Expressed as SO ₃			Type of Cement	Dense, Fully Compacted Concrete. Made with 20 mm Nominal Maximum Size Aggregates Complying with IS 383	
		In Soil		In Ground Water		Minimum Cement Content kg/m ³	Maximum Face Water-Cement Ratio
		Total SO ₃	SO ₃ in 2:1 Water: Soil Extract				
(1)	(2)	(3)	(4)	(5)	(6)	(7)	(8)
i)	1	Traces (< 0.2)	Less than 1.0	Less than 0.3	Ordinary Portland cement or Portland slag cement or Portland pozzolana cement	280	0.55
ii)	2	0.2 to 0.5	1.0 to 1.9	0.3 to 1.2	Ordinary Portland cement or Portland slag cement or Portland pozzolana cement Supersulphated cement or sulphate resisting Portland cement	330 310	0.50 0.50
iii)	3	0.5 to 1.0	1.9 to 3.1	1.2 to 2.5	Supersulphated cement or sulphate resisting Portland cement Portland pozzolana cement or Portland slag cement	330 350	0.50 0.45
iv)	4	1.0 to 2.0	3.1 to 5.0	2.5 to 5.0	Supersulphated or sulphate resisting Portland cement	370	0.45
v)	5	More than 2.0	More than 5.0	More than 5.0	Sulphate resisting Portland cement or supersulphated cement with protective coatings	400	0.40

NOTES

- Cement content given in this table is irrespective of grades of cement.
- Use of supersulphated cement is generally restricted where the prevailing temperature is above 40 °C.
- Supersulphated cement gives an acceptable life provided that the concrete is dense and prepared with a water-cement ratio of 0.4 or less, in mineral acids, down to pH 3.5.
- The cement contents given in col 6 of this table are the minimum recommended. For SO₃ contents near the upper limit of any class, cement contents above these minimum are advised.
- For severe conditions, such as thin sections under hydrostatic pressure on one side only and sections partly immersed, considerations should be given to a further reduction of water-cement ratio.
- Portland slag cement conforming to IS 455 with slag content more than 50 percent exhibits better sulphate resisting properties.
- Where chloride is encountered along with sulphates in soil or ground water, ordinary Portland cement with C₃A content from 5 to 8 percent shall be desirable to be used in concrete, instead of sulphate resisting cement. Alternatively, Portland slag cement conforming to IS 455 having more than 50 percent slag or a blend of ordinary Portland cement and slag may be used provided sufficient information is available on performance of such blended cements in these conditions.

8.2.5 Mix Constituents

8.2.5.1 General

For concrete to be durable, careful selection of the mix and materials is necessary, so that deleterious constituents do not exceed the limits.

8.2.5.2 Chlorides in concrete

Whenever there is chloride in concrete there is an increased risk of corrosion of embedded metal. The higher the chloride content, or if subsequently exposed to warm moist conditions, the greater the risk of corrosion. All constituents may contain chlorides and concrete may be contaminated by chlorides from the external environment. To minimize the chances of deterioration of concrete from harmful chemical salts, the levels of such harmful salts in concrete coming from concrete materials, that is, cement, aggregates water and admixtures, as well as by diffusion from the environment should be limited. The total amount of chloride content (as Cl) in the concrete at the time of placing shall be as given in Table 7.

The total acid soluble chloride content should be calculated from the mix proportions and the measured chloride contents of each of the constituents. Wherever possible, the total chloride content of the concrete should be determined.

8.2.5.3 Sulphates in concrete

Sulphates are present in most cements and in some aggregates; excessive amounts of water-soluble sulphate from these or other mix constituents can cause

expansion and disruption of concrete. To prevent this, the total water-soluble sulphate content of the concrete mix, expressed as SO_3 , should not exceed 4 percent by mass of the cement in the mix. The sulphate content should be calculated as the total from the various constituents of the mix.

The 4 percent limit does not apply to concrete made with supersulphated cement complying with IS 6909.

8.2.5.4 Alkali-aggregate reaction

Some aggregates containing particular varieties of silica may be susceptible to attack by alkalis (Na_2O and K_2O) originating from cement or other sources, producing an expansive reaction which can cause cracking and disruption of concrete. Damage to concrete from this reaction will normally only occur when all the following are present together:

- A high moisture level, within the concrete;
- A cement with high alkali content, or another source of alkali;
- Aggregate containing an alkali reactive constituent.

Where the service records of particular cement/aggregate combination are well established, and do not include any instances of cracking due to alkali-aggregate reaction, no further precautions should be necessary. When the materials are unfamiliar, precautions should take one of more of the following forms:

- Use of non-reactive aggregate from alternate sources.

Table 5 Minimum Cement Content, Maximum Water-Cement Ratio and Minimum Grade of Concrete for Different Exposures with Normal Weight Aggregates of 20 mm Nominal Maximum Size

(Clauses 6.1.2, 8.2.4.1 and 9.1.2)

Sl No.	Exposure	Plain Concrete			Reinforced Concrete		
		Minimum Cement Content kg/m^3	Maximum Free Water-Cement Ratio	Minimum Grade of Concrete	Minimum Cement Content kg/m^3	Maximum Free Water-Cement Ratio	Minimum Grade of Concrete
1)	(2)	(3)	(4)	(5)	(6)	(7)	(8)
i)	Mild	220	0.60	—	300	0.55	M 20
iii)	Moderate	240	0.60	M 15	300	0.50	M 25
iii)	Severe	250	0.50	M 20	320	0.45	M 30
iv)	Very severe	260	0.45	M 20	340	0.45	M 35
v)	Extreme	280	0.40	M 25	360	0.40	M 40

NOTES

1 Cement content prescribed in this table is irrespective of the grades of cement and it is inclusive of additions mentioned in 5.2. The additions such as fly ash or ground granulated blast furnace slag may be taken into account in the concrete composition with respect to the cement content and water-cement ratio if the suitability is established and as long as the maximum amounts taken into account do not exceed the limit of pozzolona and slag specified in IS 1489 (Part 1) and IS 455 respectively.

2 Minimum grade for plain concrete under mild exposure condition is not specified.

Table 6 Adjustments to Minimum Cement Contents for Aggregates Other Than 20 mm Nominal Maximum Size
(Clause 8.2.4.1)

Sl No.	Nominal Maximum Aggregate Size mm	Adjustments to Minimum Cement Contents in Table 5 kg/m ³
(1)	(2)	(3)
i)	10	+40
ii)	20	0
iii)	40	-30

Table 7 Limits of Chloride Content of Concrete
(Clause 8.2.5.2)

Sl No.	Type or Use of Concrete	Maximum Total Acid Soluble Chloride Content Expressed as kg/m ³ of Concrete
(1)	(2)	(3)
i)	Concrete containing metal and steam cured at elevated temperature and pre-stressed concrete	0.4
ii)	Reinforced concrete or plain concrete containing embedded metal	0.6
iii)	Concrete not containing embedded metal or any material requiring protection from chloride	3.0

- b) Use of low alkali ordinary Portland cement having total alkali content not more than 0.6 percent (as Na₂O equivalent).

Further advantage can be obtained by use of fly ash (Grade 1) conforming to IS 3812 or granulated blastfurnace slag conforming to IS 12089 as part replacement of ordinary Portland cement (having total alkali content as Na₂O equivalent not more than 0.6 percent), provided fly ash content is at least 20 percent or slag content is at least 50 percent.

- c) Measures to reduce the degree of saturation of the concrete during service such as use of impermeable membranes.
- d) Limiting the cement content in the concrete mix and thereby limiting total alkali content in the concrete mix. For more guidance specialist literatures may be referred.

8.2.6 Concrete in Aggressive Soils and Water

8.2.6.1 General

The destructive action of aggressive waters on concrete is progressive. The rate of deterioration decreases as the concrete is made stronger and more impermeable, and increases as the salt content of the water increases. Where structures are only partially immersed or are in contact with aggressive soils or waters on one side only,

evaporation may cause serious concentrations of salts with subsequent deterioration, even where the original salt content of the soil or water is not high.

NOTE—Guidance regarding requirements for concrete exposed to sulphate attack is given in 8.2.2.4.

8.2.6.2 Drainage

At sites where alkali concentrations are high or may become very high, the ground water should be lowered by drainage so that it will not come into direct contact with the concrete.

Additional protection may be obtained by the use of chemically resistant stone facing or a layer of plaster of Paris covered with suitable fabric, such as jute thoroughly impregnated with bituminous material.

8.2.7 Compaction, Finishing and Curing

Adequate compaction without segregation should be ensured by providing suitable workability and by employing appropriate placing and compacting equipment and procedures. Full compaction is particularly important in the vicinity of construction and movement joints and of embedded water bars and reinforcement.

Good finishing practices are essential for durable concrete.

Overworking the surface and the addition of water/cement to aid in finishing should be avoided; the resulting laitance will have impaired strength and durability and will be particularly vulnerable to freezing and thawing under wet conditions.

It is essential to use proper and adequate curing techniques to reduce the permeability of the concrete, and enhance its durability by extending the hydration of the cement, particularly in its surface zone (see 13.5).

8.2.8 Concrete in Sea-water

Concrete in sea-water or exposed directly along the sea-coast shall be at least M 20 Grade in the case of plain concrete and M 30 in case of reinforced concrete. The use of slag or pozzolana cement is advantageous under such conditions.

8.2.8.1 Special attention shall be given to the design of the mix to obtain the densest possible concrete; slag, broken brick, soft limestone, soft sandstone, or other porous or weak aggregates shall not be used.

8.2.8.2 As far as possible, preference shall be given to precast members unreinforced, well-cured and hardened, without sharp corners, and having trowel-smooth finished surfaces free from crazing, cracks or other defects; plastering should be avoided.

8.2.8.3 No construction joints shall be allowed within 600 mm below low water-level or within 600 mm of the upper and lower planes of wave action. Where

unusually severe conditions or abrasion are anticipated, such parts of the work shall be protected by bituminous or silico-fluoride coatings or stone facing bedded with bitumen.

8.2.8.4 In reinforced concrete structures, care shall be taken to protect the reinforcement from exposure to saline atmosphere during storage, fabrication and use. It may be achieved by treating the surface of reinforcement with cement wash or by suitable methods.

9 CONCRETE MIX PROPORTIONING

9.1 Mix Proportion

The mix proportions shall be selected to ensure the workability of the fresh concrete and when concrete is hardened, it shall have the required strength, durability and surface finish.

9.1.1 The determination of the proportions of cement, aggregates and water to attain the required strengths shall be made as follows:

- a) By designing the concrete mix; such concrete shall be called 'Design mix concrete', or
- b) By adopting nominal concrete mix; such concrete shall be called 'Nominal mix concrete'.

Design mix concrete is preferred to nominal mix. If design mix concrete cannot be used for any reason on the work for grades of M 20 or lower, nominal mixes may be used with the permission of engineer-in-charge, which, however, is likely to involve a higher cement content.

9.1.2 Information Required

In specifying a particular grade of concrete, the following information shall be included:

- a) Type of mix, that is, design mix concrete or nominal mix concrete;
- b) Grade designation;
- c) Type of cement;
- d) Maximum nominal size of aggregate;
- e) Minimum cement content (for design mix concrete);
- f) Maximum water-cement ratio;
- g) Workability;
- h) Mix proportion (for nominal mix concrete);
- j) Exposure conditions as per Tables 4 and 5;
- k) Maximum temperature of concrete at the time of placing;
- m) Method of placing; and
- n) Degree of supervision.

9.1.2.1 In appropriate circumstances, the following additional information may be specified:

- a) Type of aggregate.
- b) Maximum cement content, and
- c) Whether an admixture shall or shall not be used and the type of admixture and the condition of use.

9.2 Design Mix Concrete

9.2.1 As the guarantor of quality of concrete used in the construction, the constructor shall carry out the mix design and the mix so designed (not the method of design) shall be approved by the employer within the limitations of parameters and other stipulations laid down by this standard.

9.2.2 The mix shall be designed to produce the grade of concrete having the required workability and a characteristic strength not less than appropriate values given in Table 2. The target mean strength of concrete mix should be equal to the characteristic strength plus 1.65 times the standard deviation.

9.2.3 Mix design done earlier not prior to one year may be considered adequate for later work provided there is no change in source and the quality of the materials.

9.2.4 Standard Deviation

The standard deviation for each grade of concrete shall be calculated, separately.

9.2.4.1 Standard deviation based on test strength of sample

- a) *Number of test results of samples*—The total number of test strength of samples required to constitute an acceptable record for calculation of standard deviation shall be not less than 30. Attempts should be made to obtain the 30 samples, as early as possible, when a mix is used for the first time.
- b) *In case of significant changes in concrete*—When significant changes are made in the production of concrete batches (for example changes in the materials used, mix design, equipment or technical control), the standard deviation value shall be separately calculated for such batches of concrete.
- c) *Standard deviation to be brought up to date*—The calculation of the standard deviation shall be brought up to date after every change of mix design.

9.2.4.2 Assumed standard deviation

Where sufficient test results for a particular grade of concrete are not available, the value of standard deviation given in Table 8 may be assumed for design of mix in the first instance. As soon as the results of samples are available, actual calculated standard deviation shall be used and the mix designed properly.

However, when adequate past records for a similar grade exist and justify to the designer a value of standard deviation different from that shown in Table 8, it shall be permissible to use that value.

Table 8 Assumed Standard Deviation
(Clause 9.2.4.2 and Table 11)

Grade of Concrete	Assumed Standard Deviation N/mm^2
M 10	3.5
M 15	
M 20	4.0
M 25	
M 30	5.0
M 35	
M 40	
M 45	
M 50	

NOTE—The above values correspond to the site control having proper storage of cement; weigh batching of all materials; controlled addition of water; regular checking of all materials, aggregate gradings and moisture content; and periodical checking of workability and strength. Where there is deviation from the above the values given in the above table shall be increased by $1N/mm^2$.

9.3 Nominal Mix Concrete

Nominal mix concrete may be used for concrete of M 20 or lower. The proportions of materials for nominal mix concrete shall be in accordance with Table 9.

9.3.1 The cement content of the mix specified in Table 9 for any nominal mix shall be proportionately increased if the quantity of water in a mix has to be increased to overcome the difficulties of placement and compaction, so that the water-cement ratio as specified is not exceeded.

10 PRODUCTION OF CONCRETE

10.1 Quality Assurance Measures

10.1.1 In order that the properties of the completed structure be consistent with the requirements and the assumptions made during the planning and the design, adequate quality assurance measures shall be taken. The construction should result in satisfactory strength, serviceability and long term durability so as to lower the overall life-cycle cost. Quality assurance in construction activity relates to proper design, use of adequate materials and components to be supplied by the producers, proper workmanship in the execution of works by the contractor and ultimately proper care during the use of structure including timely maintenance and repair by the owner.

10.1.2 Quality assurance measures are both technical and organizational. Some common cases should be specified in a general Quality Assurance Plan which shall identify the key elements necessary to provide fitness of the structure and the means by which they are to be provided and measured with the overall purpose to provide confidence that the realized project will work satisfactorily in service fulfilling intended needs. The job of quality control and quality assurance would involve quality audit of both the inputs as well as the outputs. Inputs are in the form of materials for concrete; workmanship in all stages of batching, mixing, transportation, placing, compaction and curing; and the related plant, machinery and equipments; resulting in the output in the form of concrete in place. To ensure proper performance, it is necessary that each step in concreting which will be covered by the next step is inspected as the work proceeds (see also 17).

Table 9 Proportions for Nominal Mix Concrete

(Clauses 9.3 and 9.3.1)

Grade of Concrete	Total Quantity of Dry Aggregates by Mass per 50 kg of Cement, to be Taken as the Sum of the Individual Masses of Fine and Coarse Aggregates, kg, <i>Max</i>	Proportion of Fine Aggregate to Coarse Aggregate (by Mass)	Quantity of Water per 50 kg of Cement, <i>Max</i>
(1)	(2)	(3)	(4)
M 5	800	Generally 1:2 but subject to an upper limit of $1:1\frac{1}{2}$ and a lower limit of $1:2\frac{1}{2}$	60
M 7.5	625		45
M 10	480		34
M 15	330		32
M 20	250		30

NOTE—The proportion of the fine to coarse aggregates should be adjusted from upper limit to lower limit progressively as the grading of fine aggregates becomes finer and the maximum size of coarse aggregate becomes larger. Graded coarse aggregate shall be used.

Example

For an average grading of fine aggregate (that is, Zone II of Table 4 of IS 383), the proportions shall be $1:1\frac{1}{2}$, 1:2 and $1:2\frac{1}{2}$ for maximum size of aggregates 10 mm, 20 mm and 40 mm respectively.

10.1.3 Each party involved in the realization of a project should establish and implement a Quality Assurance Plan, for its participation in the project. Supplier's and subcontractor's activities shall be covered in the plan. The individual Quality Assurance Plans shall fit into the general Quality Assurance Plan. A Quality Assurance Plan shall define the tasks and responsibilities of all persons involved, adequate control and checking procedures, and the organization and maintaining adequate documentation of the building process and its results. Such documentation should generally include:

- a) test reports and manufacturer's certificate for materials, concrete mix design details;
- b) pour cards for site organization and clearance for concrete placement;
- c) record of site inspection of workmanship, field tests;
- d) non-conformance reports, change orders;
- e) quality control charts; and
- f) statistical analysis.

NOTE—Quality control charts are recommended wherever the concrete is in continuous production over considerable period.

10.2 Batching

To avoid confusion and error in batching, consideration should be given to using the smallest practical number of different concrete mixes on any site or in any one plant. In batching concrete, the quantity of both cement and aggregate shall be determined by mass; admixture, if solid, by mass; liquid admixture may however be measured in volume or mass; water shall be weighed or measured by volume in a calibrated tank (*see also* IS 4925).

Ready-mixed concrete supplied by ready-mixed concrete plant shall be preferred. For large and medium project sites the concrete shall be sourced from ready-mixed concrete plants or from on site or off site batching and mixing plants (*see* IS 4926).

10.2.1 Except where it can be shown to the satisfaction of the engineer-in-charge that supply of properly graded aggregate of uniform quality can be maintained over a period of work, the grading of aggregate should be controlled by obtaining the coarse aggregate in different sizes and blending them in the right proportions when required, the different sizes being stocked in separate stock-piles. The material should be stock-piled for several hours preferably a day before use. The grading of coarse and fine aggregate should be checked as frequently as possible, the frequency for a given job being determined by the engineer-in-charge to ensure that the specified grading is maintained.

10.2.2 The accuracy of the measuring equipment shall be within ± 2 percent of the quantity of cement being

measured and within ± 3 percent of the quantity of aggregate, admixtures and water being measured.

10.2.3 Proportion/Type and grading of aggregates shall be made by trial in such a way so as to obtain densest possible concrete. All ingredients of the concrete should be used by mass only.

10.2.4 Volume batching may be allowed only where weigh-batching is not practical and provided accurate bulk densities of materials to be actually used in concrete have earlier been established. Allowance for bulking shall be made in accordance with IS 2386 (Part 3). The mass volume relationship should be checked as frequently as necessary, the frequency for the given job being determined by engineer-in-charge to ensure that the specified grading is maintained.

10.2.5 It is important to maintain the water-cement ratio constant at its correct value. To this end, determination of moisture contents in both fine and coarse aggregates shall be made as frequently as possible, the frequency for a given job being determined by the engineer-in-charge according to weather conditions. The amount of the added water shall be adjusted to compensate for any observed variations in the moisture contents. For the determination of moisture content in the aggregates, IS 2386 (Part 3) may be referred to. To allow for the variation in mass of aggregate due to variation in their moisture content, suitable adjustments in the masses of aggregates shall also be made. In the absence of exact data, only in the case of nominal mixes, the amount of surface water may be estimated from the values given in Table 10.

Table 10 Surface Water Carried by Aggregate
(Clause 10.2.5)

Sl No.	Aggregate	Approximate Quantity of Surface Water	
		Percent by Mass	l/m ³
(1)	(2)	(3)	(4)
i)	Very wet sand	7.5	120
ii)	Moderately wet sand	5.0	80
iii)	Moist sand	2.5	40
iv)	¹⁾ Moist gravel or crushed rock	1.25-2.5	20-40

¹⁾ Coarser the aggregate, less the water it will carry.

10.2.6 No substitutions in materials used on the work or alterations in the established proportions, except as permitted in 10.2.4 and 10.2.5 shall be made without additional tests to show that the quality and strength of concrete are satisfactory.

10.3 Mixing

Concrete shall be mixed in a mechanical mixer. The mixer should comply with IS 1791 and IS 12119. The mixers shall be fitted with water measuring (metering) devices. The mixing shall be continued until there is a uniform distribution of the materials and the mass is

uniform in colour and consistency. If there is segregation after unloading from the mixer, the concrete should be remixed.

10.3.1 For guidance, the mixing time shall be at least 2 min. For other types of more efficient mixers, manufacturers recommendations shall be followed; for hydrophobic cement it may be decided by the engineer-in-charge.

10.3.2 Workability should be checked at frequent intervals (see IS 1199).

10.3.3 Dosages of retarders, plasticisers and superplasticisers shall be restricted to 0.5, 1.0 and 2.0 percent respectively by weight of cementitious materials and unless a higher value is agreed upon between the manufacturer and the constructor based on performance test.

11 FORMWORK

11.1 General

The formwork shall be designed and constructed so as to remain sufficiently rigid during placing and compaction of concrete, and shall be such as to prevent loss of slurry from the concrete. For further details regarding design, detailing, etc, reference may be made to IS 14687. The tolerances on the shapes, lines and dimensions shown in the drawing shall be within the limits given below:

a) Deviation from specified dimensions of cross-section of columns and beams	+ 12 - 6 mm
b) Deviation from dimensions of footings	
1) Dimensions in plan	+ 50 mm - 12
2) Eccentricity	0.02 times the width of the footing in the direction of deviation but not more than 50 mm
3) Thickness	± 0.05 times the specified thickness

These tolerances apply to concrete dimensions only, and not to positioning of vertical reinforcing steel or dowels.

11.2 Cleaning and Treatment of Formwork

All rubbish, particularly, chippings, shavings and sawdust shall be removed from the interior of the forms before the concrete is placed. The face of formwork in contact with the concrete shall be cleaned and treated with form release agent. Release agents should be applied so as to provide a thin uniform coating to the forms without coating the reinforcement.

11.3 Stripping Time

Forms shall not be released until the concrete has achieved a strength of at least twice the stress to which the concrete may be subjected at the time of removal of formwork. The strength referred to shall be that of concrete using the same cement and aggregates and admixture, if any, with the same proportions and cured under conditions of temperature and moisture similar to those existing on the work.

11.3.1 While the above criteria of strength shall be the guiding factor for removal of formwork, in normal circumstances where ambient temperature does not fall below 15°C and where ordinary Portland cement is used and adequate curing is done, following striking period may deem to satisfy the guideline given in 11.3:

Type of Formwork	Minimum Period Before Striking Formwork
a) Vertical formwork to columns, walls, beams	16-24 h
b) Soffit formwork to slabs (Props to be refixed immediately after removal of formwork)	3 days
c) Soffit formwork to beams (Props to be refixed immediately after removal of formwork)	7 days
d) Props to slabs:	
1) Spanning up to 4.5 m	7 days
2) Spanning over 4.5 m	14 days
e) Props to beams and arches:	
1) Spanning up to 6 m	14 days
2) Spanning over 6 m	21 days

For other cements and lower temperature, the stripping time recommended above may be suitably modified.

11.3.2 The number of props left under, their sizes and disposition shall be such as to be able to safely carry the full dead load of the slab, beam or arch as the case may be together with any live load likely to occur during curing or further construction.

11.3.3 Where the shape of the element is such that the formwork has re-entrant angles, the formwork shall be removed as soon as possible after the concrete has set, to avoid shrinkage cracking occurring due to the restraint imposed.

12 ASSEMBLY OF REINFORCEMENT

12.1 Reinforcement shall be bent and fixed in accordance with procedure specified in IS 2502. The high strength deformed steel bars should not be re-bent

or straightened without the approval of engineer-in-charge.

Bar bending schedules shall be prepared for all reinforcement work.

12.2 All reinforcement shall be placed and maintained in the position shown in the drawings by providing proper cover blocks, spacers, supporting bars, etc.

12.2.1 Crossing bars should not be tack-welded for assembly of reinforcement unless permitted by engineer-in-charge.

12.3 Placing of Reinforcement

Rough handling, shock loading (prior to embedment) and the dropping of reinforcement from a height should be avoided. Reinforcement should be secured against displacement outside the specified limits.

12.3.1 Tolerances on Placing of Reinforcement

Unless otherwise specified by engineer-in-charge, the reinforcement shall be placed within the following tolerances:

- | | |
|--|---------|
| a) for effective depth 200 mm
or less | ± 10 mm |
| b) for effective depth more than
200 mm | ± 15 mm |

12.3.2 Tolerance for Cover

Unless specified otherwise, actual concrete cover should not deviate from the required nominal cover by $\begin{matrix} +10 \\ 0 \end{matrix}$ mm.

Nominal cover as given in 26.4.1 should be specified to all steel reinforcement including links. Spacers between the links (or the bars where no links exist) and the formwork should be of the same nominal size as the nominal cover.

Spacers, chairs and other supports detailed on drawings, together with such other supports as may be necessary, should be used to maintain the specified nominal cover to the steel reinforcement. Spacers or chairs should be placed at a maximum spacing of 1m and closer spacing may sometimes be necessary.

Spacers, cover blocks should be of concrete of same strength or PVC.

12.4 Welded Joints or Mechanical Connections

Welded joints or mechanical connections in reinforcement may be used but in all cases of important connections, tests shall be made to prove that the joints are of the full strength of bars connected. Welding of reinforcements shall be done in accordance with the recommendations of IS 2751 and IS 9417.

12.5 Where reinforcement bars upto 12 mm for high strength deformed steel bars and up to 16 mm for mild

steel bars are bent aside at construction joints and afterwards bent back into their original positions, care should be taken to ensure that at no time is the radius of the bend less than 4 bar diameters for plain mild steel or 6 bar diameters for deformed bars. Care shall also be taken when bending back bars, to ensure that the concrete around the bar is not damaged beyond the band.

12.6 Reinforcement should be placed and tied in such a way that concrete placement be possible without segregation of the mix. Reinforcement placing should allow compaction by immersion vibrator. Within the concrete mass, different types of metal in contact should be avoided to ensure that bimetal corrosion does not take place.

13 TRANSPORTING, PLACING, COMPACTION AND CURING

13.1 Transporting and Handling

After mixing, concrete shall be transported to the formwork as rapidly as possible by methods which will prevent the segregation or loss of any of the ingredients or ingress of foreign matter or water and maintaining the required workability.

13.1.1 During hot or cold weather, concrete shall be transported in deep containers. Other suitable methods to reduce the loss of water by evaporation in hot weather and heat loss in cold weather may also be adopted.

13.2 Placing

The concrete shall be deposited as nearly as practicable in its final position to avoid rehandling. The concrete shall be placed and compacted before initial setting of concrete commences and should not be subsequently disturbed. Methods of placing should be such as to preclude segregation. Care should be taken to avoid displacement of reinforcement or movement of formwork. As a general guidance, the maximum permissible free fall of concrete may be taken as 1.5 m.

13.3 Compaction

Concrete should be thoroughly compacted and fully worked around the reinforcement, around embedded fixtures and into corners of the formwork.

13.3.1 Concrete shall be compacted using mechanical vibrators complying with IS 2505, IS 2506, IS 2514 and IS 4656. Over vibration and under vibration of concrete are harmful and should be avoided. Vibration of very wet mixes should also be avoided.

Whenever vibration has to be applied externally, the design of formwork and the disposition of vibrators should receive special consideration to ensure efficient compaction and to avoid surface blemishes.

13.4 Construction Joints and Cold Joints

Joints are a common source of weakness and, therefore, it is desirable to avoid them. If this is not possible, their number shall be minimized. Concreting shall be carried out continuously up to construction joints, the position and arrangement of which shall be indicated by the designer. Construction joints should comply with IS 11817.

Construction joints shall be placed at accessible locations to permit cleaning out of laitance, cement slurry and unsound concrete, in order to create rough/uneven surface. It is recommended to clean out laitance and cement slurry by using wire brush on the surface of joint immediately after initial setting of concrete and to clean out the same immediately thereafter. The prepared surface should be in a clean saturated surface dry condition when fresh concrete is placed, against it.

In the case of construction joints at locations where the previous pour has been cast against shuttering the recommended method of obtaining a rough surface for the previously poured concrete is to expose the aggregate with a high pressure water jet or any other appropriate means.

Fresh concrete should be thoroughly vibrated near construction joints so that mortar from the new concrete flows between large aggregates and develop proper bond with old concrete.

Where high shear resistance is required at the construction joints, shear keys may be provided.

Sprayed curing membranes and release agents should be thoroughly removed from joint surfaces.

13.5 Curing

Curing is the process of preventing the loss of moisture from the concrete whilst maintaining a satisfactory temperature regime. The prevention of moisture loss from the concrete is particularly important if the water-cement ratio is low, if the cement has a high rate of strength development, if the concrete contains granulated blast furnace slag or pulverised fuel ash. The curing regime should also prevent the development of high temperature gradients within the concrete.

The rate of strength development at early ages of concrete made with supersulphated cement is significantly reduced at lower temperatures. Supersulphated cement concrete is seriously affected by inadequate curing and the surface has to be kept moist for at least seven days.

13.5.1 Moist Curing

Exposed surfaces of concrete shall be kept continuously in a damp or wet condition by ponding or by covering with a layer of sacking, canvas, hessian or similar materials and kept constantly wet for at least seven days from the date of placing concrete in case

of ordinary Portland Cement and at least 10 days where mineral admixtures or blended cements are used. The period of curing shall not be less than 10 days for concrete exposed to dry and hot weather conditions. In the case of concrete where mineral admixtures or blended cements are used, it is recommended that above minimum periods may be extended to 14 days.

13.5.2 Membrane Curing

Approved curing compounds may be used in lieu of moist curing with the permission of the engineer-in-charge. Such compounds shall be applied to all exposed surfaces of the concrete as soon as possible after the concrete has set. Impermeable membranes such as polyethylene sheeting covering closely the concrete surface may also be used to provide effective barrier against evaporation.

13.5.3 For the concrete containing Portland pozzolana cement, Portland slag cement or mineral admixture, period of curing may be increased.

13.6 Supervision

It is exceedingly difficult and costly to alter concrete once placed. Hence, constant and strict supervision of all the items of the construction is necessary during the progress of the work, including the proportioning and mixing of the concrete. Supervision is also of extreme importance to check the reinforcement and its placing before being covered.

13.6.1 Before any important operation, such as concreting or stripping of the formwork is started, adequate notice shall be given to the construction supervisor.

14 CONCRETING UNDER SPECIAL CONDITIONS

14.1 Work in Extreme Weather Conditions

During hot or cold weather, the concreting should be done as per the procedure set out in IS 7861 (Part 1) or IS 7861 (Part 2).

14.2 Under-Water Concreting

14.2.1 When it is necessary to deposit concrete under water, the methods, equipment, materials and proportions of the mix to be used shall be submitted to and approved by the engineer-in-charge before the work is started.

14.2.2 Under-water concrete should have a slump recommended in 7.1. The water-cement ratio shall not exceed 0.6 and may need to be smaller, depending on the grade of concrete or the type of chemical attack. For aggregates of 40 mm maximum particle size, the cement content shall be at least 350 kg/m³ of concrete.

14.2.3 Coffers-dams or forms shall be sufficiently tight

to ensure still water if practicable, and in any case to reduce the flow of water to less than 3 m/min through the space into which concrete is to be deposited. Cofferdams or forms in still water shall be sufficiently tight to prevent loss of mortar through the walls. De-watering by pumping shall not be done while concrete is being placed or until 24 h thereafter.

14.2.4 Concrete cast under water should not fall freely through the water. Otherwise it may be leached and become segregated. Concrete shall be deposited continuously until it is brought to the required height. While depositing, the top surface shall be kept as nearly level as possible and the formation of seams avoided. The methods to be used for depositing concrete under water shall be one of the following:

- a) *Tremie*—The concrete is placed through vertical pipes the lower end of which is always inserted sufficiently deep into the concrete which has been placed previously but has not set. The concrete emerging from the pipe pushes the material that has already been placed to the side and upwards and thus does not come into direct contact with water.

When concrete is to be deposited under water by means of tremie, the top section of the tremie shall be a hopper large enough to hold one entire batch of the mix or the entire contents the transporting bucket, if any. The tremie pipe shall be not less than 200 mm in diameter and shall be large enough to allow a free flow of concrete and strong enough to withstand the external pressure of the water in which it is suspended, even if a partial vacuum develops inside the pipe. Preferably, flanged steel pipe of adequate strength for the job should be used. A separate lifting device shall be provided for each tremie pipe with its hopper at the upper end. Unless the lower end of the pipe is equipped with an approved automatic check valve, the upper end of the pipe shall be plugged with a wadding of the gunny sacking or other approved material before delivering the concrete to the tremie pipe through the hopper, so that when the concrete is forced down from the hopper to the pipe, it will force the plug (and along with it any water in the pipe) down the pipe and out of the bottom end, thus establishing a continuous stream of concrete. It will be necessary to raise slowly the tremie in order to cause a uniform flow of the concrete, but the tremie shall not be emptied so that water enters the pipe. At all times after the placing of concrete is started and until all the concrete is placed, the lower end of the tremie pipe shall be below the top surface of the plastic concrete. This will cause the concrete to build up from below instead of flowing out over the

surface, and thus avoid formation of laitance layers. If the charge in the tremie is lost while depositing, the tremie shall be raised above the concrete surface, and unless sealed by a check valve, it shall be re-plugged at the top end, as at the beginning, before refilling for depositing concrete.

- b) *Direct placement with pumps*—As in the case of the tremie method, the vertical end piece of the pipe line is always inserted sufficiently deep into the previously cast concrete and should not move to the side during pumping.
- c) *Drop bottom bucket*—The top of the bucket shall be covered with a canvas flap. The bottom doors shall open freely downward and outward when tripped. The bucket shall be filled completely and lowered slowly to avoid backwash. The bottom doors shall not be opened until the bucket rests on the surface upon which the concrete is to be deposited and when discharged, shall be withdrawn slowly until well above the concrete.
- d) *Bags*—Bags of at least 0.028 m³ capacity of jute or other coarse cloth shall be filled about two-thirds full of concrete, the spare end turned under so that bag is square ended and securely tied. They shall be placed carefully in header and stretcher courses so that the whole mass is interlocked. Bags used for this purpose shall be free from deleterious materials.
- e) *Grouting*—A series of round cages made from 50 mm mesh of 6 mm steel and extending over the full height to be concreted shall be prepared and laid vertically over the area to be concreted so that the distance between centres of the cages and also to the faces of the concrete shall not exceed one metre. Stone aggregate of not less than 50 mm nor more than 200 mm size shall be deposited outside the steel cages over the full area and height to be concreted with due care to prevent displacement of the cages.

A stable 1:2 cement-sand grout with a water-cement ratio of not less than 0.6 and not more than 0.8 shall be prepared in a mechanical mixer and sent down under pressure (about 0.2 N/mm²) through 38 to 50 mm diameter pipes terminating into steel cages, about 50 mm above the bottom of the concrete. As the grouting proceeds, the pipe shall be raised gradually up to a height of not more than 6 000 mm above its starting level after which it may be withdrawn and placed into the next cage for further grouting by the same procedure.

After grouting the whole area for a height of about 600 mm, the same operation shall be repeated, if necessary, for the next layer of

600 mm and so on.

The amount of grout to be sent down shall be sufficient to fill all the voids which may be either ascertained or assumed as 55 percent of the volume to be concreted.

14.2.5 To minimize the formulation of laitance, great care shall be exercised not to disturb the concrete as far as possible while it is being deposited.

15 SAMPLING AND STRENGTH OF DESIGNED CONCRETE MIX

15.1 General

Samples from fresh concrete shall be taken as per IS 1199 and cubes shall be made, cured and tested at 28 days in accordance with IS 516.

15.1.1 In order to get a relatively quicker idea of the quality of concrete, optional tests on beams for modulus of rupture at 72 ± 2 h or at 7 days, or compressive strength tests at 7 days may be carried out in addition to 28 days compressive strength test. For this purpose the values should be arrived at based on actual testing. In all cases, the 28 days compressive strength specified in Table 2 shall alone be the criterion for acceptance or rejection of the concrete.

15.2 Frequency of Sampling

15.2.1 Sampling Procedure

A random sampling procedure shall be adopted to ensure that each concrete batch shall have a reasonable chance of being tested that is, the sampling should be spread over the entire period of concreting and cover all mixing units.

15.2.2 Frequency

The minimum frequency of sampling of concrete of each grade shall be in accordance with the following:

Quantity of Concrete in the Work, m ³	Number of Samples
1 - 5	1
6 - 15	2
16 - 30	3
31 - 50	4
51 and above	4 plus one additional sample for each additional 50 m ³ or part thereof

NOTE—At least one sample shall be taken from each shift. Where concrete is produced at continuous production unit, such as ready-mixed concrete plant, frequency of sampling may be agreed upon mutually by suppliers and purchasers.

15.3 Test Specimen

Three test specimens shall be made for each sample

for testing at 28 days. Additional samples may be required for various purposes such as to determine the strength of concrete at 7 days or at the time of striking the formwork, or to determine the duration of curing, or to check the testing error. Additional samples may also be required for testing samples cured by accelerated methods as described in IS 9103. The specimen shall be tested as described in IS 516.

15.4 Test Results of Sample

The test results of the sample shall be the average of the strength of three specimens. The individual variation should not be more than ± 15 percent of the average. If more, the test results of the sample are invalid.

16 ACCEPTANCE CRITERIA

16.1 Compressive Strength

The concrete shall be deemed to comply with the strength requirements when both the following condition are met:

- The mean strength determined from any group of four consecutive test results complies with the appropriate limits in col 2 of Table 11.
- Any individual test result complies with the appropriate limits in col 3 of Table 11.

16.2 Flexural Strength

When both the following conditions are met, the concrete complies with the specified flexural strength.

- The mean strength determined from any group of four consecutive test results exceeds the specified characteristic strength by at least 0.3 N/mm².
- The strength determined from any test result is not less than the specified characteristic strength less 0.3 N/mm².

16.3 Quantity of Concrete Represented by Strength Test Results

The quantity of concrete represented by a group of four consecutive test results shall include the batches from which the first and last samples were taken together with all intervening batches.

For the individual test result requirements given in col 2 of Table 11 or in item (b) of 16.2, only the particular batch from which the sample was taken shall be at risk.

Where the mean rate of sampling is not specified the maximum quantity of concrete that four consecutive test results represent shall be limited to 60 m³.

16.4 If the concrete is deemed not to comply pursuant to 16.3, the structural adequacy of the parts affected shall be investigated (*see* 17) and any consequential action as needed shall be taken.

16.5 Concrete of each grade shall be assessed separately.

16.6 Concrete is liable to be rejected if it is porous or honey-combed, its placing has been interrupted without providing a proper construction joint, the reinforcement has been displaced beyond the tolerances specified, or construction tolerances have not been met. However, the hardened concrete may be accepted after carrying out suitable remedial measures to the satisfaction of the engineer-in-charge.

17 INSPECTION AND TESTING OF STRUCTURES

17.1 Inspection

To ensure that the construction complies with the design an inspection procedure should be set up covering materials, records, workmanship and construction.

17.1.1 Tests should be made on reinforcement and the constituent materials of concrete in accordance with the relevant standards. Where applicable, use should be made of suitable quality assurance schemes.

17.1.2 Care should be taken to see that:

- design and detail are capable of being executed to a suitable standard, with due allowance for dimensional tolerances;
- there are clear instructions on inspection standards;
- there are clear instructions on permissible deviations;
- elements critical to workmanship, structural performance, durability and appearance are identified; and

e) there is a system to verify that the quality is satisfactory in individual parts of the structure, especially the critical ones.

17.2 Immediately after stripping the formwork, all concrete shall be carefully inspected and any defective work or small defects either removed or made good before concrete has thoroughly hardened.

17.3 Testing

In case of doubt regarding the grade of concrete used, either due to poor workmanship or based on results of cube strength tests, compressive strength tests of concrete on the basis of 17.4 and/or load test (see 17.6) may be carried out.

17.4 Core Test

17.4.1 The points from which cores are to be taken and the number of cores required shall be at the discretion of the engineer-in-charge and shall be representative of the whole of concrete concerned. In no case, however, shall fewer than three cores be tested.

17.4.2 Cores shall be prepared and tested as described in IS 516.

17.4.3 Concrete in the member represented by a core test shall be considered acceptable if the average equivalent cube strength of the cores is equal to at least 85 percent of the cube strength of the grade of concrete specified for the corresponding age and no individual core has a strength less than 75 percent.

17.5 In case the core test results do not satisfy the requirements of 17.4.3 or where such tests have not been done, load test (17.6) may be resorted to.

17.6 Load Tests for Flexural Member

17.6.1 Load tests should be carried out as soon as

Table 11 Characteristic Compressive Strength Compliance Requirement

(Clauses 16.1 and 16.3)

Specified Grade	Mean of the Group of 4 Non-Overlapping Consecutive Test Results in N/mm ²	Individual Test Results in N/mm ²
(1)	(2)	(3)
M 15	$\geq f_{ck} + 0.825 \times$ established standard deviation (rounded off to nearest 0.5 N/mm ²)	$\geq f_{ck}^{-3}$ N/mm ²
	or	
	$f_{ck} + 3$ N/mm ² , whichever is greater	
M 20 or above	$\geq f_{ck} + 0.825 \times$ established standard deviation (rounded off to nearest 0.5 N/mm ²)	$\geq f_{ck}^{-4}$ N/mm ²
	or	
	$f_{ck} + 4$ N/mm ² , whichever is greater	

NOTE—In the absence of established value of standard deviation, the values given in Table 8 may be assumed, and attempt should be made to obtain results of 30 samples as early as possible to establish the value of standard deviation.

possible after expiry of 28 days from the time of placing of concrete.

17.6.2 The structure should be subjected to a load equal to full dead load of the structure plus 1.25 times the imposed load for a period of 24 h and then the imposed load shall be removed.

NOTE—Dead load includes self weight of the structural members plus weight of finishes and walls or partitions, if any, as considered in the design.

17.6.3 The deflection due to imposed load only shall be recorded. If within 24 h of removal of the imposed load, the structure does not recover at least 75 percent of the deflection under superimposed load, the test may be repeated after a lapse of 72 h. If the recovery is less than 80 percent, the structure shall be deemed to be unacceptable.

17.6.3.1 If the maximum deflection in mm, shown during 24 h under load is less than $40l^2/D$, where l is the effective span in m; and D , the overall depth of the section in mm, it is not necessary for the recovery to be measured and the recovery provisions of **17.6.3** shall

not apply.

17.7 Members Other Than Flexural Members

Members other than flexural members should be preferably investigated by analysis.

17.8 Non-destructive Tests

Non-destructive tests are used to obtain estimation of the properties of concrete in the structure. The methods adopted include ultrasonic pulse velocity [see IS 13311 (Part 1)] and rebound hammer [IS 13311 (Part 2)], probe penetration, pullout and maturity. Non-destructive tests provide alternatives to core tests for estimating the strength of concrete in a structure, or can supplement the data obtained from a limited number of cores. These methods are based on measuring a concrete property that bears some relationship to strength. The accuracy of these methods, in part, is determined by the degree of correlation between strength and the physical quality measured by the non-destructive tests.

Any of these methods may be adopted, in which case the acceptance criteria shall be agreed upon prior to testing.

SECTION 3 GENERAL DESIGN CONSIDERATION

18 BASES FOR DESIGN

18.1 Aim of Design

The aim of design is the achievement of an acceptable probability that structures being designed will perform satisfactorily during their intended life. With an appropriate degree of safety, they should sustain all the loads and deformations of normal construction and use and have adequate durability and adequate resistance to the effects of misuse and fire.

18.2 Methods of Design

18.2.1 Structure and structural elements shall normally be designed by Limit State Method. Account should be taken of accepted theories, experiment and experience and the need to design for durability. Calculations alone do not produce safe, serviceable and durable structures. Suitable materials, quality control, adequate detailing and good supervision are equally important.

18.2.2 Where the Limit State Method can not be conveniently adopted, Working Stress Method (*see* Annex B) may be used.

18.2.3 Design Based on Experimental Basis

Designs based on experimental investigations on models or full size structure or element may be accepted if they satisfy the primary requirements of 18.1 and subject to experimental details and the analysis connected therewith being approved by the engineer-in-charge.

18.2.3.1 Where the design is based on experimental investigation on full size structure or element, load tests shall be carried out to ensure the following:

- a) The structure shall satisfy the requirements for deflection (*see* 23.2) and cracking (*see* 35.3.2) when subjected to a load for 24 h equal to the characteristic load multiplied by 1.33 γ_f , where γ_f shall be taken from Table 18, for the limit state of serviceability. If within 24 h of the removal of the load, the structure does not show a recovery of at least 75 percent of the maximum deflection shown during the 24 h under the load, the test loading should be repeated after a lapse of 72 h. The recovery after the second test should be at least 75 percent of the maximum deflection shown during the second test.

NOTE—If the maximum deflection in mm, shown during 24 h under load is less than $40 l^2/D$ where l is the effective span in m; and D is the overall depth of the section in mm, it is not necessary for the recovery to be measured.

- b) The structure shall have adequate strength to sustain for 24 h, a total load equal to the characteristic load multiplied by 1.33 γ_f where γ_f shall

be taken from Table 18 for the limit state of collapse.

18.3 Durability, Workmanship and Materials

It is assumed that the quality of concrete, steel and other materials and of the workmanship, as verified by inspections, is adequate for safety, serviceability and durability.

18.4 Design Process

Design, including design for durability, construction and use in service should be considered as a whole. The realization of design objectives requires compliance with clearly defined standards for materials, production, workmanship and also maintenance and use of structure in service.

19 LOADS AND FORCES

19.1 General

In structural design, account shall be taken of the dead, imposed and wind loads and forces such as those caused by earthquake, and effects due to shrinkage, creep, temperature, etc, where applicable.

19.2 Dead Loads

Dead loads shall be calculated on the basis of unit weights which shall be established taking into consideration the materials specified for construction.

19.2.1 Alternatively, the dead loads may be calculated on the basis of unit weights of materials given in IS 875 (Part 1). Unless more accurate calculations are warranted, the unit weights of plain concrete and reinforced concrete made with sand and gravel or crushed natural stone aggregate may be taken as 24 kN/m³ and 25 kN/m³ respectively.

19.3 Imposed Loads, Wind Loads and Snow Loads

Imposed loads, wind loads and snow loads shall be assumed in accordance with IS 875 (Part 2), IS 875 (Part 3) and IS 875 (Part 4) respectively.

19.4 Earthquake Forces

The earthquake forces shall be calculated in accordance with IS 1893.

19.5 Shrinkage, Creep and Temperature Effects

If the effects of shrinkage, creep and temperature are liable to affect materially the safety and serviceability of the structure, these shall be taken into account in the calculations (*see* 6.2.4, 6.2.5 and 6.2.6) and IS 875 (Part 5).

19.5.1 In ordinary buildings, such as low rise dwellings whose lateral dimension do not exceed 45 m, the

effects due to temperature fluctuations and shrinkage and creep can be ignored in design calculations.

19.6 Other Forces and Effects

In addition, account shall be taken of the following forces and effects if they are liable to affect materially the safety and serviceability of the structure:

- a) Foundation movement (*see* IS 1904),
- b) Elastic axial shortening,
- c) Soil and fluid pressures [*see* IS 875 (Part 5)],
- d) Vibration,
- e) Fatigue,
- f) Impact [*see* IS 875 (Part 5)],
- g) Erection loads [*see* IS 875 (Part 2)], and
- h) Stress concentration effect due to point load and the like.

19.7 Combination of Loads

The combination of loads shall be as given in IS 875 (Part 5).

19.8 Dead Load Counteracting Other Loads and Forces

When dead load counteracts the effects due to other loads and forces in structural member or joint, special care shall be exercised by the designer to ensure adequate safety for possible stress reversal.

19.9 Design Load

Design load is the load to be taken for use in the appropriate method of design; it is the characteristic load in case of working stress method and characteristic load with appropriate partial safety factors for limit state design.

20 STABILITY OF THE STRUCTURE

20.1 Overturning

The stability of a structure as a whole against overturning shall be ensured so that the restoring moment shall be not less than the sum of 1.2 times the maximum overturning moment due to the characteristic dead load and 1.4 times the maximum overturning moment due to the characteristic imposed loads. In cases where dead load provides the restoring moment, only 0.9 times the characteristic dead load shall be considered. Restoring moment due to imposed loads shall be ignored.

20.1.1 The anchorages or counterweights provided for overhanging members (during construction and service) should be such that static equilibrium should remain, even when overturning moment is doubled.

20.2 Sliding

The structure shall have a factor against sliding of not less than 1.4 under the most adverse combination of the applied characteristic forces. In this case only 0.9 times the characteristic dead load shall be taken into account.

20.3 Probable Variation in Dead Load

To ensure stability at all times, account shall be taken of probable variations in dead load during construction, repair or other temporary measures. Wind and seismic loading shall be treated as imposed loading.

20.4 Moment Connection

In designing the framework of a building provisions shall be made by adequate moment connections or by a system of bracings to effectively transmit all the horizontal forces to the foundations.

20.5 Lateral Sway

Under transient wind load the lateral sway at the top should not exceed $H/500$, where H is the total height of the building. For seismic loading, reference should be made to IS 1893.

21 FIRE RESISTANCE

21.1 A structure or structural element required to have fire resistance should be designed to possess an appropriate degree of resistance to flame penetration; heat transmission and failure. The fire resistance of a structural element is expressed in terms of time in hours in accordance with IS 1641. Fire resistance of concrete elements depends upon details of member size, cover to steel reinforcement detailing and type of aggregate (normal weight or light weight) used in concrete. General requirements for fire protection are given in IS 1642.

21.2 Minimum requirements of concrete cover and member dimensions for normal-weight aggregate concrete members so as to have the required fire resistance shall be in accordance with 26.4.3 and Fig.1 respectively.

21.3 The reinforcement detailing should reflect the changing pattern of the structural section and ensure that both individual elements and the structure as a whole contain adequate support, ties, bonds and anchorages for the required fire resistance.

21.3.1 Additional measures such as application of fire resistant finishes, provision of fire resistant false ceilings and sacrificial steel in tensile zone, should be adopted in case the nominal cover required exceeds 40 mm for beams and 35 mm for slabs, to give protection against spalling.

21.4 Specialist literature may be referred to for determining fire resistance of the structures which have not been covered in Fig. 1 or Table 16A.

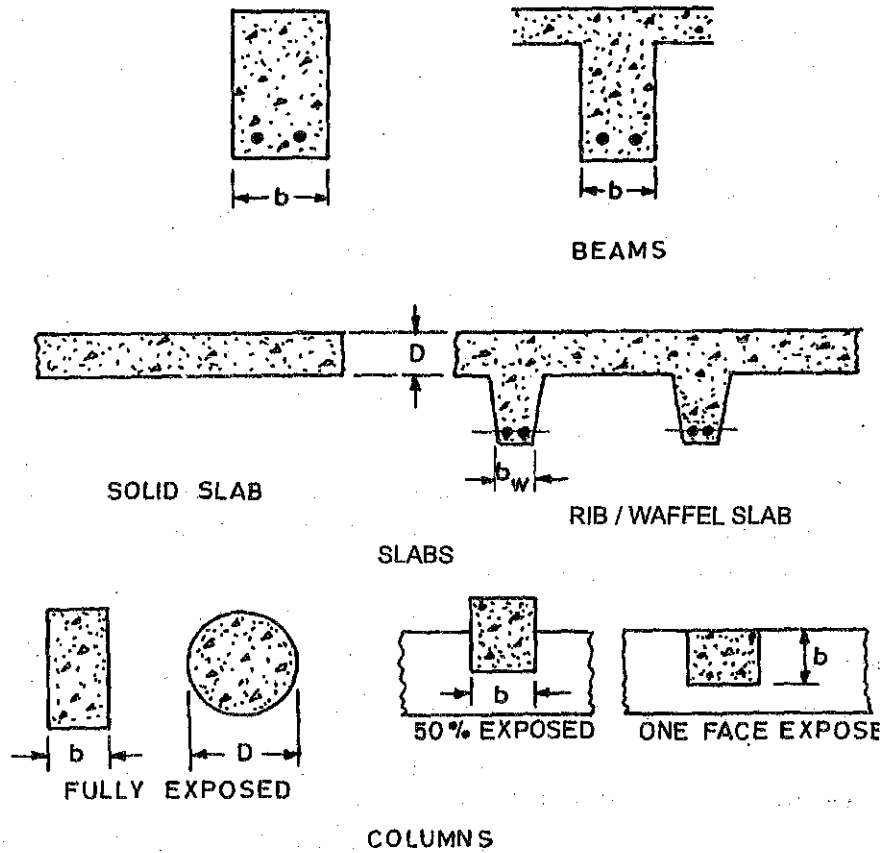

Fire Resistance h	Minimum Beam Width b	Rib Width of Slabs b_w	Minimum Thickness of Floors D	Column Dimension (b or D)			Minimum Wall Thickness		
				Fully Exposed	50% Exposed	One Face Exposed	$p < 0.4\%$	$0.4\% \leq p \leq 1\%$	$p > 1\%$
				mm	mm	mm	mm	mm	mm
0.5	200	125	75	150	125	100	150	100	100
1	200	125	95	200	160	120	150	120	100
1.5	200	125	110	250	200	140	175	140	100
2	200	125	125	300	200	160	-	160	100
3	240	150	150	400	300	200	-	200	150
4	280	175	170	450	350	240	-	240	180

NOTES

- 1 These minimum dimensions relate specifically to the covers given in Table 16A.
- 2 p is the percentage of steel reinforcement.

FIG. 1 MINIMUM DIMENSIONS OF REINFORCED CONCRETE MEMBERS FOR FIRE RESISTANCE

22 ANALYSIS

22.1 General

All structures may be analyzed by the linear elastic theory to calculate internal actions produced by design loads. In lieu of rigorous elastic analysis, a simplified analysis as given in 22.4 for frames and as given in 22.5 for continuous beams may be adopted.

22.2 Effective Span

Unless otherwise specified, the effective span of a member shall be as follows:

- a) *Simply Supported Beam or Slab*—The effective span of a member that is not built integrally with its supports shall be taken as clear span plus the effective depth of slab or beam or centre to centre of supports, whichever is less.

- b) *Continuous Beam or Slab* — In the case of continuous beam or slab, if the width of the support is less than $1/12$ of the clear span, the effective span shall be as in 22.2 (a). If the supports are wider than $1/12$ of the clear span or 600 mm whichever is less, the effective span shall be taken as under:
- 1) For end span with one end fixed and the other continuous or for intermediate spans, the effective span shall be the clear span between supports;
 - 2) For end span with one end free and the other continuous, the effective span shall be equal to the clear span plus half the effective depth of the beam or slab or the clear span plus half the width of the discontinuous support, whichever is less;
 - 3) In the case of spans with roller or rocket bearings, the effective span shall always be the distance between the centres of bearings.
- c) *Cantilever* — The effective length of a cantilever shall be taken as its length to the face of the support plus half the effective depth except where it forms the end of a continuous beam where the length to the centre of support shall be taken.
- d) *Frames* — In the analysis of a continuous frame, centre to centre distance shall be used.

22.3 Stiffness

22.3.1 Relative Stiffness

The relative stiffness of the members may be based on the moment of inertia of the section determined on the basis of any one of the following definitions:

- a) *Gross section* — The cross-section of the member ignoring reinforcement;
- b) *Transformed section* — The concrete cross-section plus the area of reinforcement transformed on the basis of modular ratio (see B-1.3); or
- c) *Cracked section* — The area of concrete in compression plus the area of reinforcement transformed on the basis of modular ratio.

The assumptions made shall be consistent for all the members of the structure throughout any analysis.

22.3.2 For deflection calculations, appropriate values of moment of inertia as specified in Annex C should be used.

22.4 Structural Frames

The simplifying assumptions as given in 22.4.1 to 22.4.3 may be used in the analysis of frames.

22.4.1 Arrangement of Imposed Load

- a) Consideration may be limited to combinations of:
 - 1) Design dead load on all spans with full design imposed load on two adjacent spans; and
 - 2) Design dead load on all spans with full design imposed load on alternate spans.
- b) When design imposed load does not exceed three-fourths of the design dead load, the load arrangement may be design dead load and design imposed load on all the spans.

NOTE — For beams and slabs continuous over support 22.4.1(a) may be assumed.

22.4.2 Substitute Frame

For determining the moments and shears at any floor or roof level due to gravity loads, the beams at that level together with columns above and below with their far ends fixed may be considered to constitute the frame.

22.4.2.1 Where side sway consideration becomes critical due to unsymmetry in geometry or loading, rigorous analysis may be required.

22.4.3 For lateral loads, simplified methods may be used to obtain the moments and shears for structures that are symmetrical. For unsymmetrical or very tall structures, more rigorous methods should be used.

22.5 Moment and Shear Coefficients for Continuous Beams

22.5.1 Unless more exact estimates are made, for beams of uniform cross-section which support substantially uniformly distributed loads over three or more spans which do not differ by more than 15 percent of the longest, the bending moments and shear forces used in design may be obtained using the coefficients given in Table 12 and Table 13 respectively.

For moments at supports where two unequal spans meet or in case where the spans are not equally loaded, the average of the two values for the negative moment at the support may be taken for design.

Where coefficients given in Table 12 are used for calculation of bending moments, redistribution referred to in 22.7 shall not be permitted.

22.5.2 Beams and Slabs Over Free End Supports

Where a member is built into a masonry wall which develops only partial restraint, the member shall be designed to resist a negative moment at the face of the support of $Wl/24$ where W is the total design load and l is the effective span, or such other restraining moment as may be shown to be applicable. For such a condition shear coefficient given in Table 13 at the end support may be increased by 0.05.

Table 12 Bending Moment Coefficients
(Clause 22.5.1)

Type of Load	Span Moments		Support Moments	
	Near Middle of End Span	At Middle of Interior Span	At Support Next to the End Support	At Other Interior Supports
(1)	(2)	(3)	(4)	(5)
Dead load and imposed load (fixed)	$+\frac{1}{12}$	$+\frac{1}{16}$	$-\frac{1}{10}$	$-\frac{1}{12}$
Imposed load (not fixed)	$+\frac{1}{10}$	$+\frac{1}{12}$	$-\frac{1}{9}$	$-\frac{1}{9}$

NOTE — For obtaining the bending moment, the coefficient shall be multiplied by the total design load and effective span.

Table 13 Shear for Coefficients
(Clauses 22.5.1 and 22.5.2)

Type of Load	At End Support	At Support Next to the End Support		At All Other Interior Supports
		Outer Side	Inner Side	
(1)	(2)	(3)	(4)	(5)
Dead load and imposed load (fixed)	0.4	0.6	0.55	0.5
Imposed load (not fixed)	0.45	0.6	0.6	0.6

NOTE — For obtaining the shear force, the coefficient shall be multiplied by the total design load.

22.6 Critical Sections for Moment and Shear

22.6.1 For monolithic construction, the moments computed at the face of the supports shall be used in the design of the members at those sections. For non-monolithic construction the design of the member shall be done keeping in view 22.2.

22.6.2 Critical Section for Shear

The shears computed at the face of the support shall be used in the design of the member at that section except as in 22.6.2.1.

22.6.2.1 When the reaction in the direction of the applied shear introduces compression into the end region of the member, sections located at a distance less than d from the face of the support may be designed for the same shear as that computed at distance d (see Fig. 2).

NOTE—The above clauses are applicable for beams generally carrying uniformly distributed load or where the principal load is located farther than $2d$ from the face of the support.

22.7 Redistribution of Moments

Redistribution of moments may be done in accordance with 37.1.1 for limit state method and in accordance with B-1.2 for working stress method. However, where simplified analysis using coefficients is adopted, redistribution of moments shall not be done.

23 BEAMS

23.0 Effective Depth

Effective depth of a beam is the distance between the centroid of the area of tension reinforcement and the maximum compression fibre, excluding the thickness of finishing material not placed monolithically with the member and the thickness of any concrete provided to allow for wear. This will not apply to deep beams.

23.1 T-Beams and L-Beams

23.1.1 General

A slab which is assumed to act as a compression flange of a T-beam or L-beam shall satisfy the following:

- The slab shall be cast integrally with the web, or the web and the slab shall be effectively bonded together in any other manner; and
- If the main reinforcement of the slab is parallel to the beam, transverse reinforcement shall be provided as in Fig. 3; such reinforcement shall not be less than 60 percent of the main reinforcement at mid span of the slab.

23.1.2 Effective Width of Flange

In the absence of more accurate determination, the effective width of flange may be taken as the following

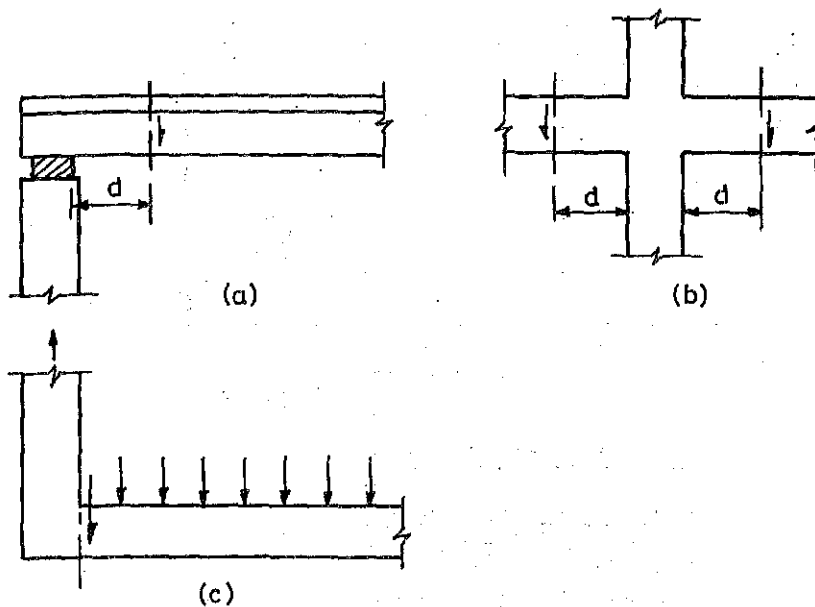

FIG. 2 TYPICAL SUPPORT CONDITIONS FOR LOCATING FACTORED SHEAR FORCE

but in no case greater than the breadth of the web plus half the sum of the clear distances to the adjacent beams on either side.

- For T-beams, $b_f = \frac{l_0}{6} + b_w + 6 D_f$
- For L-beams, $b_f = \frac{l_0}{12} + b_w + 3 D_f$
- For isolated beams, the effective flange width shall be obtained as below but in no case greater than the actual width:

$$\text{T-beam, } b_f = \frac{l_0}{\left(\frac{l_0}{b}\right) + 4} + b_w$$

$$\text{L-beam, } b_f = \frac{0.5 l_0}{\left(\frac{l_0}{b}\right) + 4} + b_w$$

where

- b_f = effective width of flange,
- l_0 = distance between points of zero moments in the beam,
- b_w = breadth of the web,
- D_f = thickness of flange, and
- b = actual width of the flange.

NOTE — For continuous beams and frames, ' l_0 ' may be assumed as 0.7 times the effective span.

23.2 Control of Deflection

The deflection of a structure or part thereof shall not adversely affect the appearance or efficiency of the

structure or finishes or partitions. The deflection shall generally be limited to the following:

- The final deflection due to all loads including the effects of temperature, creep and shrinkage and measured from the as-cast level of the supports of floors, roofs and all other horizontal members, should not normally exceed span/250.
- The deflection including the effects of temperature, creep and shrinkage occurring after erection of partitions and the application of finishes should not normally exceed span/350 or 20 mm whichever is less.

23.2.1 The vertical deflection limits may generally be assumed to be satisfied provided that the span to depth ratios are not greater than the values obtained as below:

- Basic values of span to effective depth ratios for spans up to 10 m:

Cantilever	7
Simply supported	20
Continuous	26

- For spans above 10 m, the values in (a) may be multiplied by 10/span in metres, except for cantilever in which case deflection calculations should be made.
- Depending on the area and the stress of steel for tension reinforcement, the values in (a) or (b) shall be modified by multiplying with the modification factor obtained as per Fig. 4.
- Depending on the area of compression reinforcement, the value of span to depth ratio be further modified by multiplying with the modification factor obtained as per Fig. 5.

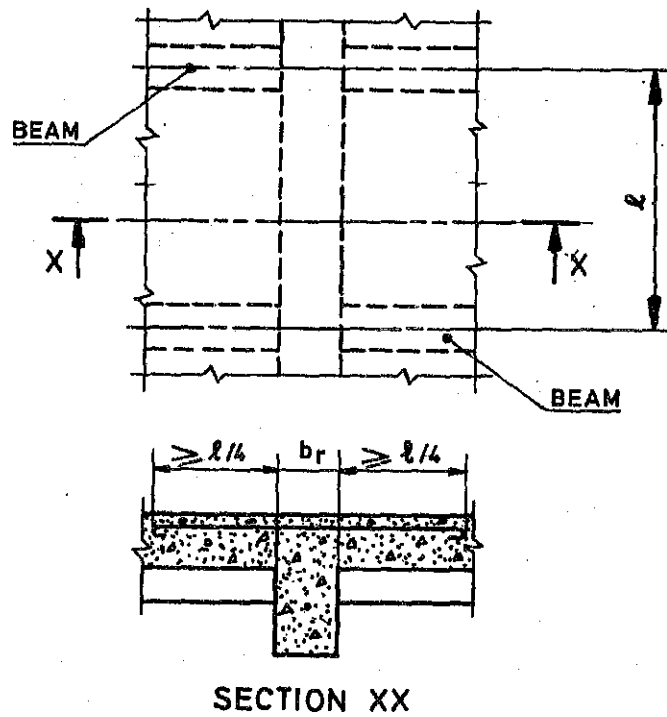
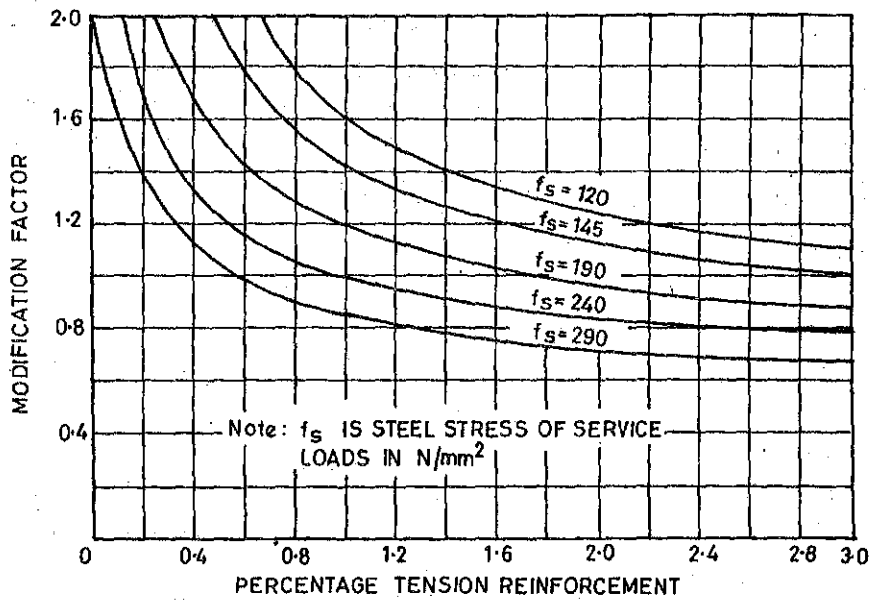

FIG. 3 TRANSVERSE REINFORCEMENT IN FLANGE OF T-BEAM WHEN MAIN REINFORCEMENT OF SLAB IS PARALLEL TO THE BEAM

e) For flanged beams, the values of (a) or (b) be modified as per Fig. 6 and the reinforcement percentage for use in Fig. 4 and 5 should be based

on area of section equal to $b_f d$.

NOTE—When deflections are required to be calculated; the method given in Annex C may be used.



$$f_s = 0.58 f_y \frac{\text{Area of cross-section of steel required}}{\text{Area of cross-section of steel provided}}$$

FIG. 4 MODIFICATION FACTOR FOR TENSION REINFORCEMENT

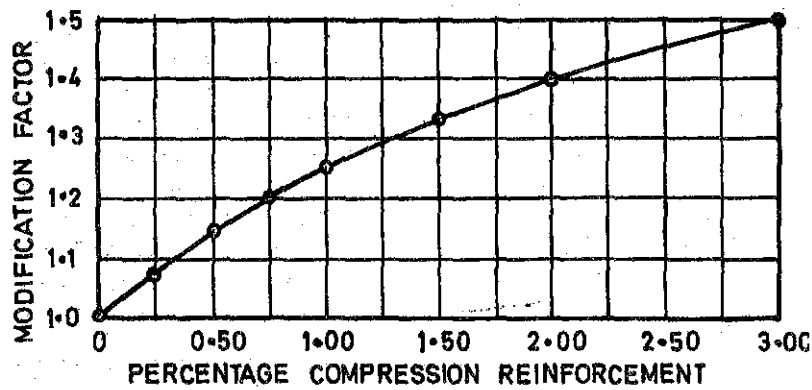

FIG. 5 MODIFICATION FACTOR FOR COMPRESSION REINFORCEMENT

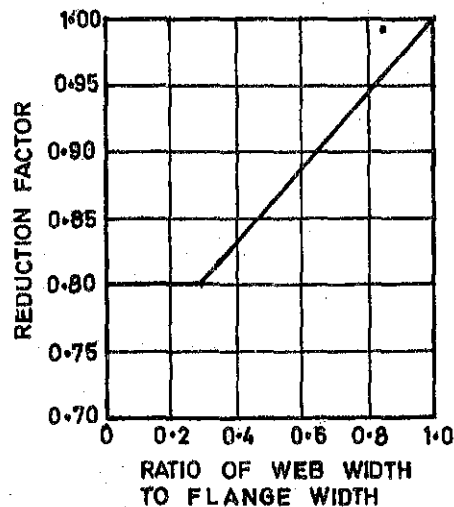

FIG. 6 REDUCTION FACTORS FOR RATIOS OF SPAN TO EFFECTIVE DEPTH FOR FLANGED BEAMS

23.3 Slenderness Limits for Beams to Ensure Lateral Stability

A simply supported or continuous beam shall be so proportioned that the clear distance between the lateral restraints does not exceed $60b$ or $\frac{250b^2}{d}$ whichever is less, where d is the effective depth of the beam and b the breadth of the compression face midway between the lateral restraints.

For a cantilever, the clear distance from the free end of the cantilever to the lateral restraint shall not exceed $25b$ or $\frac{100b^2}{d}$ whichever is less.

24 SOLID SLABS

24.1 General

The provisions of 23.2 for beams apply to slabs also.

NOTES

- For slabs spanning in two directions, the shorter of the two spans should be used for calculating the span to effective depth ratios.
- For two-way slabs of shorter spans (up to 3.5 m) with mild steel reinforcement, the span to overall depth ratios given below may generally be assumed to satisfy vertical deflection limits for loading class up to 3 kN/m^2 .

Simply supported slabs 35

Continuous slabs 40

For high strength deformed bars of grade Fe 415, the values given above should be multiplied by 0.8.

24.2 Slabs Continuous Over Supports

Slabs spanning in one direction and continuous over supports shall be designed according to the provisions applicable to continuous beams.

24.3 Slabs Monolithic with Supports

Bending moments in slabs (except flat slabs) constructed monolithically with the supports shall be calculated by taking such slabs either as continuous over supports and

capable of free rotation, or as members of a continuous framework with the supports, taking into account the stiffness of such supports. If such supports are formed due to beams which justify fixity at the support of slabs, then the effects on the supporting beam, such as, the bending of the web in the transverse direction of the beam and the torsion in the longitudinal direction of the beam, wherever applicable, shall also be considered in the design of the beam.

24.3.1 For the purpose of calculation of moments in slabs in a monolithic structure, it will generally be sufficiently accurate to assume that members connected to the ends of such slabs are fixed in position and direction at the ends remote from their connections with the slabs.

24.3.2 Slabs Carrying Concentrated Load

24.3.2.1 If a solid slab supported on two opposite edges, carries concentrated loads the maximum bending moment caused by the concentrated loads shall be assumed to be resisted by an effective width of slab (measured parallel to the supporting edges) as follows:

- a) For a single concentrated load, the effective width shall be calculated in accordance with the following equation provided that it shall not exceed the actual width of the slab:

$$b_{ef} = kx \left(1 - \frac{x}{l_{ef}} \right) + a$$

where

- b_{ef} = effective width of slab,
 k = constant having the values given in Table 14 depending upon the ratio of the width of the slab (l) to the effective span l_{ef} ,
 x = distance of the centroid of the concentrated load from nearer support,
 l_{ef} = effective span, and
 a = width of the contact area of the concentrated load from nearer support measured parallel to the supported edge.

And provided further that in case of a load near the unsupported edge of a slab, the effective width shall not exceed the above value nor half the above value plus the distance of the load from the unsupported edge.

- b) For two or more concentrated loads placed in a line in the direction of the span, the bending moment per metre width of slab shall be calculated separately for each load according to its appropriate effective width of slab calculated as in (a) above and added together for design calculations.

- c) For two or more loads not in a line in the direction of the span, if the effective width of slab for one load does not overlap the effective width of slab for another load, both calculated as in (a) above, then the slab for each load can be designed separately. If the effective width of slab for one load overlaps the effective width of slab for an adjacent load, the overlapping portion of the slab shall be designed for the combined effect of the two loads.

Table 14 Values of k for Simply Supported and Continuous Slabs
(Clause 24.3.2.1)

l/h_{ef}	k for Simply Supported Slabs	k for Continuous Slabs
0.1	0.4	0.4
0.2	0.8	0.8
0.3	1.16	1.16
0.4	1.48	1.44
0.5	1.72	1.68
0.6	1.96	1.84
0.7	2.12	1.96
0.8	2.24	2.08
0.9	2.36	2.16
1.0 and above	2.48	2.24

- d) For cantilever solid slabs, the effective width shall be calculated in accordance with the following equation:

$$b_{ef} = 1.2 a_1 + a$$

where

- b_{ef} = effective width,
 a_1 = distance of the concentrated load from the face of the cantilever support, and
 a = width of contact area of the concentrated load measured parallel to the supporting edge.

Provided that the effective width of the cantilever slab shall not exceed one-third the length of the cantilever slab measured parallel to the fixed edge.

And provided further that when the concentrated load is placed near the extreme ends of the length of cantilever slab in the direction parallel to the fixed edge, the effective width shall not exceed the above value, nor shall it exceed half the above value plus the distance of the concentrated load from the extreme end measured in the direction parallel to the fixed edge.

24.3.2.2 For slabs other than solid slabs, the effective width shall depend on the ratio of the transverse and longitudinal flexural rigidities of the slab. Where this ratio is one, that is, where the transverse and longitudinal flexural rigidities are approximately equal, the value of effective width as found for solid slabs may be used. But as the ratio decreases, proportionately smaller value shall be taken.

24.3.2.3 Any other recognized method of analysis for cases of slabs covered by 24.3.2.1 and 24.3.2.2 and for all other cases of slabs may be used with the approval of the engineer-in-charge.

24.3.2.4 The critical section for checking shear shall be as given in 34.2.4.1.

24.4 Slabs Spanning in Two Directions at Right Angles

The slabs spanning in two directions at right angles and carrying uniformly distributed load may be designed by any acceptable theory or by using coefficients given in Annex D. For determining bending moments in slabs spanning in two directions at right angles and carrying concentrated load, any accepted method approved by the engineer-in-charge may be adopted.

NOTE—The most commonly used elastic methods are based on Pigeaud's or Westergaard's theory and the most commonly used limit state of collapse method is based on Johansen's yield-line theory.

24.4.1 Restrained Slab with Unequal Conditions at Adjacent Panels

In some cases the support moments calculated from Table 26 for adjacent panels may differ significantly. The following procedure may be adopted to adjust them:

- Calculate the sum of moments at midspan and supports (neglecting signs).
- Treat the values from Table 26 as fixed end moments.
- According to the relative stiffness of adjacent spans, distribute the fixed end moments across the supports, giving new support moments.
- Adjust midspan moment such that, when added to the support moments from (c) (neglecting

signs), the total should be equal to that from (a). If the resulting support moments are significantly greater than the value from Table 26, the tension steel over the supports will need to be extended further. The procedure should be as follows:

- Take the span moment as parabolic between supports: its maximum value is as found from (d).
- Determine the points of contraflexure of the new support moments [from (c)] with the span moment [from (1)].
- Extend half the support tension steel at each end to at least an effective depth or 12 bar diameters beyond the nearest point of contraflexure.
- Extend the full area of the support tension steel at each end to half the distance from (3).

24.5 Loads on Supporting Beams

The loads on beams supporting solid slabs spanning in two directions at right angles and supporting uniformly distributed loads, may be assumed to be in accordance with Fig. 7.

25 COMPRESSION MEMBERS

25.1 Definitions

25.1.1 Column or strut is a compression member, the effective length of which exceeds three times the least lateral dimension.

25.1.2 Short and Slender Compression Members

A compression member may be considered as short when both the slenderness ratios $\frac{l_{ex}}{D}$ and $\frac{l_{ey}}{b}$ are less than 12:

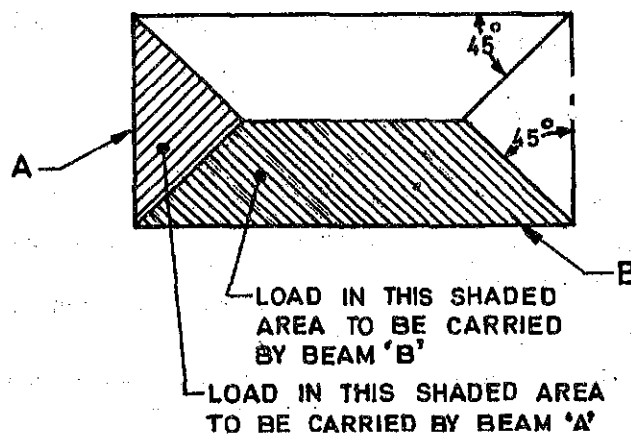

FIG. 7 LOAD CARRIED BY SUPPORTING BEAMS

where

- l_{ex} = effective length in respect of the major axis,
 D = depth in respect of the major axis,
 l_{ey} = effective length in respect of the minor axis, and
 b = width of the member.

It shall otherwise be considered as a slender compression member.

25.1.3 Unsupported Length

The unsupported length, l , of a compression member shall be taken as the clear distance between end restraints except that:

- in flat slab construction, it shall be clear distance between the floor and the lower extremity of the capital, the drop panel or slab whichever is the least.
- in beam and slab construction, it shall be the clear distance between the floor and the underside of the shallower beam framing into the columns in each direction at the next higher floor level.
- in columns restrained laterally by struts, it shall be the clear distance between consecutive struts in each vertical plane, provided that to be an adequate support, two such struts shall meet the columns at approximately the same level and the angle between vertical planes through the struts shall not vary more than 30° from a right angle. Such struts shall be of adequate dimensions and shall have sufficient anchorage to restrain the member against lateral deflection.
- in columns restrained laterally by struts or beams, with brackets used at the junction, it shall be the clear distance between the floor and the lower edge of the bracket, provided that the bracket width equals that of the beam strut and is at least half that of the column.

25.2 Effective Length of Compression Members

In the absence of more exact analysis, the effective length l_{ef} of columns may be obtained as described in Annex E.

25.3 Slenderness Limits for Columns

25.3.1 The unsupported length between end restraints shall not exceed 60 times the least lateral dimension of a column.

25.3.2 If, in any given plane, one end of a column is unrestrained, its unsupported length, l , shall not exceed

$$\frac{100b^2}{D}$$

where

- b = width of that cross-section, and
 D = depth of the cross-section measured in the plane under consideration.

25.4 Minimum Eccentricity

All columns shall be designed for minimum eccentricity, equal to the unsupported length of column/500 plus lateral dimensions/30, subject to a minimum of 20 mm. Where bi-axial bending is considered, it is sufficient to ensure that eccentricity exceeds the minimum about one axis at a time.

26 REQUIREMENTS GOVERNING REINFORCEMENT AND DETAILING

26.1 General

Reinforcing steel of same type and grade shall be used as main reinforcement in a structural member. However, simultaneous use of two different types or grades of steel for main and secondary reinforcement respectively is permissible.

26.1.1 Bars may be arranged singly, or in pairs in contact, or in groups of three or four bars bundled in contact. Bundled bars shall be enclosed within stirrups or ties. Bundled bars shall be tied together to ensure the bars remaining together. Bars larger than 32 mm diameter shall not be bundled, except in columns.

26.1.2 The recommendations for detailing for earthquake-resistant construction given in IS 13920 should be taken into consideration, where applicable (see also IS 4326).

26.2 Development of Stress in Reinforcement

The calculated tension or compression in any bar at any section shall be developed on each side of the section by an appropriate development length or end anchorage or by a combination thereof.

26.2.1 Development Length of Bars

The development length L_d is given by

$$L_d = \frac{\phi \sigma_s}{4 \tau_{bd}}$$

where

- ϕ = nominal diameter of the bar,
 σ_s = stress in bar at the section considered at design load, and
 τ_{bd} = design bond stress given in 26.2.1.1.

NOTES

- The development length includes anchorage values of hooks in tension reinforcement.
- For bars of sections other than circular, the development length should be sufficient to develop the stress in the bar by bond.

26.2.1.1 Design bond stress in limit state method for plain bars in tension shall be as below:

Grade of concrete	M 20	M 25	M 30	M 35	M 40 and above
Design bond stress, τ_{bd} , N/mm ²	1.2	1.4	1.5	1.7	1.9

For deformed bars conforming to IS 1786 these values shall be increased by 60 percent.

For bars in compression, the values of bond stress for bars in tension shall be increased by 25 percent.

The values of bond stress in working stress design, are given in B-2.1.

26.2.1.2 Bars bundled in contact

The development length of each bar of bundled bars shall be that for the individual bar, increased by 10 percent for two bars in contact, 20 percent for three bars in contact and 33 percent for four bars in contact.

26.2.2 Anchoring Reinforcing Bars

26.2.2.1 Anchoring bars in tension

- a) Deformed bars may be used without end anchorages provided development length requirement is satisfied. Hooks should normally be provided for plain bars in tension.
- b) *Bends and hooks* — Bends and hooks shall conform to IS 2502
 - 1) *Bends*—The anchorage value of bend shall be taken as 4 times the diameter of the bar for each 45° bend subject to a maximum of 16 times the diameter of the bar.
 - 2) *Hooks*—The anchorage value of a standard U-type hook shall be equal to 16 times the diameter of the bar.

26.2.2.2 Anchoring bars in compression

The anchorage length of straight bar in compression shall be equal to the development length of bars in compression as specified in 26.2.1. The projected length of hooks, bends and straight lengths beyond bends if provided for a bar in compression, shall only be considered for development length.

26.2.2.3 Mechanical devices for anchorage

Any mechanical or other device capable of developing the strength of the bar without damage to concrete may be used as anchorage with the approval of the engineer-in-charge.

26.2.2.4 Anchoring shear reinforcement

- a) *Inclined bars* — The development length shall be as for bars in tension; this length shall be measured as under:
 - 1) In tension zone, from the end of the sloping or inclined portion of the bar, and

- 2) In the compression zone, from the mid depth of the beam.

- b) *Stirrups*—Notwithstanding any of the provisions of this standard, in case of secondary reinforcement, such as stirrups and transverse ties, complete development lengths and anchorage shall be deemed to have been provided when the bar is bent through an angle of at least 90° round a bar of at least its own diameter and is continued beyond the end of the curve for a length of at least eight diameters, or when the bar is bent through an angle of 135° and is continued beyond the end of the curve for a length of at least six bar diameters or when the bar is bent through an angle of 180° and is continued beyond the end of the curve for a length of at least four bar diameters.

26.2.2.5 Bearing stresses at bends

The bearing stress in concrete for bends and hooks described in IS 2502 need not be checked. The bearing stress inside a bend in any other bend shall be calculated as given below:

$$\text{Bearing stress} = \frac{F_{bt}}{r\phi}$$

where

F_{bt} = tensile force due to design loads in a bar or group of bars,

r = internal radius of the bend, and

ϕ = size of the bar or, in bundle, the size of bar of equivalent area.

For limit state method of design, this stress shall not

exceed $\frac{1.5 f_{ck}}{1+2\phi/a}$ where f_{ck} is the characteristic cube

strength of concrete and a , for a particular bar or group of bars in contact shall be taken as the centre to centre distance between bars or groups of bars perpendicular to the plane of the bend; for a bar or group of bars adjacent to the face of the member a shall be taken as the cover plus size of bar (ϕ). For working stress method of design, the bearing stress shall

not exceed $\frac{f_{ck}}{1+2\phi/a}$.

26.2.2.6 If a change in direction of tension or compression reinforcement induces a resultant force acting outward tending to split the concrete, such force

should be taken up by additional links or stirrups. Bent tension bar at a re-entrant angle should be avoided.

26.2.3 Curtailment of Tension Reinforcement in Flexural Members

26.2.3.1 For curtailment, reinforcement shall extend beyond the point at which it is no longer required to resist flexure for a distance equal to the effective depth of the member or 12 times the bar diameter, whichever is greater except at simple support or end of cantilever. In addition 26.2.3.2 to 26.2.3.5 shall also be satisfied.

NOTE—A point at which reinforcement is no longer required to resist flexure is where the resistance moment of the section, considering only the continuing bars, is equal to the design moment.

26.2.3.2 Flexural reinforcement shall not be terminated in a tension zone unless any one of the following conditions is satisfied:

- The shear at the cut-off point does not exceed two-thirds that permitted, including the shear strength of web reinforcement provided.
- Stirrup area in excess of that required for shear and torsion is provided along each terminated bar over a distance from the cut-off point equal to three-fourths the effective depth of the member. The excess stirrup area shall be not less than $0.4 bs/f_y$, where b is the breadth of beam, s is the spacing and f_y is the characteristic strength of reinforcement in N/mm^2 . The resulting spacing shall not exceed $d/8 \beta_b$ where β_b is the ratio of the area of bars cut-off to the total area of bars at the section, and d is the effective depth.
- For 36 mm and smaller bars, the continuing bars provide double the area required for flexure at the cut-off point and the shear does not exceed three-fourths that permitted.

26.2.3.3 Positive moment reinforcement

- At least one-third the positive moment reinforcement in simple members and one-fourth the positive moment reinforcement in continuous members shall extend along the same face of the member into the support, to a length equal to $L_d/3$.
- When a flexural member is part of the primary lateral load resisting system, the positive reinforcement required to be extended into the support as described in (a) shall be anchored to develop its design stress in tension at the face of the support.
- At simple supports and at points of inflection, positive moment tension reinforcement shall be limited to a diameter such that L_d computed for f_d by 26.2.1 does not exceed

$$\frac{M_1}{V} + L_0$$

where

M_1 = moment of resistance of the section assuming all reinforcement at the section to be stressed to f_d ;

f_d = $0.87 f_y$ in the case of limit state design and the permissible stress σ_{st} in the case of working stress design;

V = shear force at the section due to design loads;

L_0 = sum of the anchorage beyond the centre of the support and the equivalent anchorage value of any hook or mechanical anchorage at simple support; and at a point of inflection, L_0 is limited to the effective depth of the members or 12ϕ , whichever is greater; and

ϕ = diameter of bar.

The value of M_1/V in the above expression may be increased by 30 percent when the ends of the reinforcement are confined by a compressive reaction.

26.2.3.4 Negative moment reinforcement

At least one-third of the total reinforcement provided for negative moment at the support shall extend beyond the point of inflection for a distance not less than the effective depth of the member of 12ϕ or one-sixteenth of the clear span whichever is greater.

26.2.3.5 Curtailment of bundled bars

Bars in a bundle shall terminate at different points spaced apart by not less than 40 times the bar diameter except for bundles stopping at a support.

26.2.4 Special Members

Adequate end anchorage shall be provided for tension reinforcement in flexural members where reinforcement stress is not directly proportional to moment, such as sloped, stepped, or tapered footings; brackets; deep beams; and members in which the tension reinforcement is not parallel to the compression face.

26.2.5 Reinforcement Splicing

Where splices are provided in the reinforcing bars, they shall as far as possible be away from the sections of maximum stress and be staggered. It is recommended that splices in flexural members should not be at sections where the bending moment is more than 50 percent of the moment of resistance; and not more than half the bars shall be spliced at a section.

Where more than one-half of the bars are spliced at a section or where splices are made at points of maximum stress, special precautions shall be taken,

such as increasing the length of lap and/or using spirals or closely-spaced stirrups around the length of the splice.

26.2.5.1 Lap splices

- a) Lap splices shall not be used for bars larger than 36 mm; for larger diameters, bars may be welded (*see* 12.4); in cases where welding is not practicable, lapping of bars larger than 36 mm may be permitted, in which case additional spirals should be provided around the lapped bars.
- b) Lap splices shall be considered as staggered if the centre to centre distance of the splices is not less than 1.3 times the lap length calculated as described in (c).
- c) Lap length including anchorage value of hooks for bars in flexural tension shall be L_d (*see* 26.2.1) or 30ϕ whichever is greater and for direct tension shall be $2L_d$ or 30ϕ whichever is greater. The straight length of the lap shall not be less than 15ϕ or 200 mm. The following provisions shall also apply:

Where lap occurs for a tension bar located at:

- 1) top of a section as cast and the minimum cover is less than twice the diameter of the lapped bar, the lap length shall be increased by a factor of 1.4.
- 2) corner of a section and the minimum cover to either face is less than twice the diameter of the lapped bar or where the clear distance between adjacent laps is less than 75 mm or 6 times the diameter of lapped bar, whichever is greater, the lap length should be increased by a factor of 1.4.

Where both condition (1) and (2) apply, the lap length should be increased by a factor of 2.0.

NOTE—Splices in tension members shall be enclosed in spirals made of bars not less than 6 mm diameter with pitch not more than 100 mm.

- d) The lap length in compression shall be equal to the development length in compression, calculated as described in 26.2.1, but not less than 24ϕ .
- e) When bars of two different diameters are to be spliced, the lap length shall be calculated on the basis of diameter of the smaller bar.
- f) When splicing of welded wire fabric is to be carried out, lap splices of wires shall be made so that overlap measured between the extreme cross wires shall be not less than the spacing of cross wires plus 100 mm.
- g) In case of bundled bars, lapped splices of bundled bars shall be made by splicing one bar

at a time; such individual splices within a bundle shall be staggered.

26.2.5.2 Strength of welds

The following values may be used where the strength of the weld has been proved by tests to be at least as great as that of the parent bar.

- a) *Splices in compression* — For welded splices and mechanical connection, 100 percent of the design strength of joined bars.
- b) *Splices in tension*
 - 1) 80 percent of the design strength of welded bars (100 percent if welding is strictly supervised and if at any cross-section of the member not more than 20 percent of the tensile reinforcement is welded).
 - 2) 100 percent of design strength of mechanical connection.

26.2.5.3 End-bearing splices

End-bearing splices shall be used only for bars in compression. The ends of the bars shall be square cut and concentric bearing ensured by suitable devices.

26.3 Spacing of Reinforcement

26.3.1 For the purpose of this clause, the diameter of a round bar shall be its nominal diameter, and in the case of bars which are not round or in the case of deformed bars or crimped bars, the diameter shall be taken as the diameter of a circle giving an equivalent effective area. Where spacing limitations and minimum concrete cover (*see* 26.4) are based on bar diameter, a group of bars bundled in contact shall be treated as a single bar of diameter derived from the total equivalent area.

26.3.2 Minimum Distance Between Individual Bars

The following shall apply for spacing of bars:

- a) The horizontal distance between two parallel main reinforcing bars shall usually be not less than the greatest of the following:
 - 1) The diameter of the bar if the diameters are equal,
 - 2) The diameter of the larger bar if the diameters are unequal, and
 - 3) 5 mm more than the nominal maximum size of coarse aggregate.

NOTE—This does not preclude the use of larger size of aggregates beyond the congested reinforcement in the same member; the size of aggregates may be reduced around congested reinforcement to comply with this provision.

- b) Greater horizontal distance than the minimum specified in (a) should be provided wherever possible. However when needle vibrators are

used the horizontal distance between bars of a group may be reduced to two-thirds the nominal maximum size of the coarse aggregate, provided that sufficient space is left between groups of bars to enable the vibrator to be immersed.

- c) Where there are two or more rows of bars, the bars shall be vertically in line and the minimum vertical distance between the bars shall be 15 mm, two-thirds the nominal maximum size of aggregate or the maximum size of bars, whichever is greater.

26.3.3 Maximum Distance Between Bars in Tension

Unless the calculation of crack widths shows that a greater spacing is acceptable, the following rules shall be applied to flexural members in normal internal or external conditions of exposure.

- a) *Beams* — The horizontal distance between parallel reinforcement bars, or groups, near the tension face of a beam shall not be greater than the value given in Table 15 depending on the amount of redistribution carried out in analysis and the characteristic strength of the reinforcement.
- b) *Slabs*
- 1) The horizontal distance between parallel main reinforcement bars shall not be more than three times the effective depth of solid slab or 300 mm whichever is smaller.
 - 2) The horizontal distance between parallel reinforcement bars provided against shrinkage and temperature shall not be more than five times the effective depth of a solid slab or 450 mm whichever is smaller.

26.4 Nominal Cover to Reinforcement

26.4.1 Nominal Cover

Nominal cover is the design depth of concrete cover to all steel reinforcements, including links. It is the dimension used in design and indicated in the drawings. It shall be not less than the diameter of the bar.

26.4.2 Nominal Cover to Meet Durability Requirement

Minimum values for the nominal cover of normal-weight aggregate concrete which should be provided to all reinforcement, including links depending on the condition of exposure described in 8.2.3 shall be as given in Table 16.

26.4.2.1 However for a longitudinal reinforcing bar in a column nominal cover shall in any case not be less than 40 mm, or less than the diameter of such bar. In the case of columns of minimum dimension of 200 mm or under, whose reinforcing bars do not exceed 12 mm, a nominal cover of 25 mm may be used.

26.4.2.2 For footings minimum cover shall be 50 mm.

26.4.3 Nominal Cover to Meet Specified Period of Fire Resistance

Minimum values of nominal cover of normal-weight aggregate concrete to be provided to all reinforcement including links to meet specified period of fire resistance shall be given in Table 16A.

26.5 Requirements of Reinforcement for Structural Members

26.5.1 Beams

26.5.1.1 Tension reinforcement

- a) *Minimum reinforcement*—The minimum area of tension reinforcement shall be not less than that

Table 15 Clear Distance Between Bars
(Clause 26.3.3)

f_y	Percentage Redistribution to or from Section Considered				
	- 30	- 15	0	+ 15	+ 30
	Clear Distance Between Bars				
N/mm ²	mm	mm	mm	mm	mm
250	215	260	300	300	300
415	125	155	180	210	235
500	105	130	150	175	195

NOTE — The spacings given in the table are not applicable to members subjected to particularly aggressive environments unless in the calculation of the moment of resistance, f_y has been limited to 300 N/mm² in limit state design and σ_s limited to 165 N/mm² in working stress design.

Table 16 Nominal Cover to Meet Durability Requirements
(Clause 26.4.2)

Exposure	Nominal Concrete Cover in mm not Less Than
Mild	20
Moderate	30
Severe	45
Very severe	50
Extreme	75

NOTES

- 1 For main reinforcement up to 12 mm diameter bar for mild exposure the nominal cover may be reduced by 5 mm.
- 2 Unless specified otherwise, actual concrete cover should not deviate from the required nominal cover by +10 mm
- 3 For exposure condition 'severe' and 'very severe', reduction of 5 mm may be made, where concrete grade is M35 and above.

Table 16A
Nominal Cover to Meet Specified Period of Fire Resistance
(Clauses 21.4 and 26.4.3 and Fig. 1)

Fire Resistance	Nominal Cover						
	Beams		Slabs		Ribs		Columns
	Simply supported	Continuous	Simply supported	Continuous	Simply supported	Continuous	
h	mm	mm	mm	mm	mm	mm	mm
0.5	20	20	20	20	20	20	40
1	20	20	20	20	20	20	40
1.5	20	20	25	20	<u>35</u>	20	40
2	<u>40</u>	30	<u>35</u>	25	45	<u>35</u>	40
3	60	<u>40</u>	45	<u>35</u>	55	45	40
4	70	50	55	45	65	55	40

NOTES

- 1 The nominal covers given relate specifically to the minimum member dimensions given in Fig. 1.
- 2 Cases that lie below the bold line require attention to the additional measures necessary to reduce the risks of spalling (see 21.3.1).

given by the following:

$$\frac{A_s}{bd} = \frac{0.85}{f_y}$$

where

- A_s = minimum area of tension reinforcement,
 b = breadth of beam or the breadth of the web of T-beam,
 d = effective depth, and
 f_y = characteristic strength of reinforcement in N/mm².

- b) **Maximum reinforcement**—The maximum area of tension reinforcement shall not exceed $0.04 bD$.

26.5.1.2 Compression reinforcement

The maximum area of compression reinforcement shall not exceed $0.04 bD$. Compression reinforcement in beams shall be enclosed by stirrups for effective lateral restraint. The arrangement of stirrups shall be as specified in 26.5.3.2.

26.5.1.3 Side face reinforcement

Where the depth of the web in a beam exceeds 750 mm, side face reinforcement shall be provided along the two faces. The total area of such reinforcement shall be not less than 0.1 percent of the web area and shall be distributed equally on two faces at a spacing not exceeding 300 mm or web thickness whichever is less.

26.5.1.4 Transverse reinforcement in beams for shear and torsion

The transverse reinforcement in beams shall be taken around the outer-most tension and compression bars. In T-beams and I-beams, such reinforcement shall pass around longitudinal bars located close to the outer face of the flange.

26.5.1.5 Maximum spacing of shear reinforcement

The maximum spacing of shear reinforcement measured along the axis of the member shall not exceed $0.75 d$ for vertical stirrups and d for inclined stirrups at 45°, where d is the effective depth of the section

under consideration. In no case shall the spacing exceed 300 mm.

26.5.1.6 Minimum shear reinforcement

Minimum shear reinforcement in the form of stirrups shall be provided such that:

$$\frac{A_{sv}}{bs_v} \geq \frac{0.4}{0.87 f_y}$$

where

A_{sv} = total cross-sectional area of stirrup legs effective in shear,

s_v = stirrup spacing along the length of the member,

b = breadth of the beam or breadth of the web of flanged beam, and

f_y = characteristic strength of the stirrup reinforcement in N/mm^2 which shall not be taken greater than 415 N/mm^2 .

Where the maximum shear stress calculated is less than half the permissible value and in members of minor structural importance such as lintels, this provision need not be complied with.

26.5.1.7 Distribution of torsion reinforcement

When a member is designed for torsion (see 41 or B-6) torsion reinforcement shall be provided as below:

- a) The transverse reinforcement for torsion shall be rectangular closed stirrups placed perpendicular to the axis of the member. The spacing of the stirrups shall not exceed the least of

x_1 , $\frac{x_1 + y_1}{4}$ and 300 mm, where x_1 and y_1 are respectively the short and long dimensions of the stirrup.

- b) Longitudinal reinforcement shall be placed as close as is practicable to the corners of the cross-section and in all cases, there shall be at least one longitudinal bar in each corner of the ties. When the cross-sectional dimension of the member exceeds 450 mm, additional longitudinal bars shall be provided to satisfy the requirements of minimum reinforcement and spacing given in 26.5.1.3.

26.5.1.8 Reinforcement in flanges of T-and L-beams shall satisfy the requirements in 23.1.1(b). Where flanges are in tension, a part of the main tension reinforcement shall be distributed over the effective flange width or a width equal to one-tenth of the span, whichever is smaller. If the effective flange width exceeds one-tenth of the span, nominal longitudinal reinforcement shall be provided in the outer portions of the flange.

26.5.2 Slabs

The rules given in 26.5.2.1 and 26.5.2.2 shall apply to slabs in addition to those given in the appropriate clauses.

26.5.2.1 Minimum reinforcement

The mild steel reinforcement in either direction in slabs shall not be less than 0.15 percent of the total cross-sectional area. However, this value can be reduced to 0.12 percent when high strength deformed bars or welded wire fabric are used.

26.5.2.2 Maximum diameter

The diameter of reinforcing bars shall not exceed one-eighth of the total thickness of the slab.

26.5.3 Columns

26.5.3.1 Longitudinal reinforcement

- a) The cross-sectional area of longitudinal reinforcement, shall be not less than 0.8 percent nor more than 6 percent of the gross cross-sectional area of the column.

NOTE — The use of 6 percent reinforcement may involve practical difficulties in placing and compacting of concrete; hence lower percentage is recommended. Where bars from the columns below have to be lapped with those in the column under consideration, the percentage of steel shall usually not exceed 4 percent.

- b) In any column that has a larger cross-sectional area than that required to support the load, the minimum percentage of steel shall be based upon the area of concrete required to resist the direct stress and not upon the actual area.
- c) The minimum number of longitudinal bars provided in a column shall be four in rectangular columns and six in circular columns.
- d) The bars shall not be less than 12 mm in diameter.
- e) A reinforced concrete column having helical reinforcement shall have at least six bars of longitudinal reinforcement within the helical reinforcement.
- f) In a helically reinforced column, the longitudinal bars shall be in contact with the helical reinforcement and equidistant around its inner circumference.
- g) Spacing of longitudinal bars measured along the periphery of the column shall not exceed 300 mm.
- h) In case of pedestals in which the longitudinal reinforcement is not taken in account in strength calculations, nominal longitudinal reinforcement not less than 0.15 percent of the cross-sectional area shall be provided.

NOTE— Pedestal is a compression member, the effective length of which does not exceed three times the least lateral dimension.

26.5.3.2 Transverse reinforcement

a) *General*—A reinforced concrete compression member shall have transverse or helical reinforcement so disposed that every longitudinal bar nearest to the compression face has effective lateral support against buckling subject to provisions in (b). The effective lateral support is given by transverse reinforcement either in the form of circular rings capable of taking up circumferential tension or by polygonal links (lateral ties) with internal angles not exceeding 135° . The ends of the transverse reinforcement shall be properly anchored [see 26.2.2.4 (b)].

b) Arrangement of transverse reinforcement

- 1) If the longitudinal bars are not spaced more than 75 mm on either side, transverse reinforcement need only to go round corner and alternate bars for the purpose of providing effective lateral supports (see Fig. 8).
- 2) If the longitudinal bars spaced at a distance of not exceeding 48 times the diameter of the tie are effectively tied in two directions, additional longitudinal bars in between these bars need to be tied in one direction by open ties (see Fig. 9).
- 3) Where the longitudinal reinforcing bars in a compression member are placed in more than one row, effective lateral support to the longitudinal bars in the inner rows may be assumed to have been provided if:
 - i) transverse reinforcement is provided for the outer-most row in accordance with 26.5.3.2, and
 - ii) no bar of the inner row is closer to the nearest compression face than three times the diameter of the largest bar in the inner row (see Fig. 10).
- 4) Where the longitudinal bars in a compression member are grouped (not in contact) and each group adequately tied with transverse reinforcement in accordance with 26.5.3.2, the transverse reinforcement for the compression member as a whole may be provided on the assumption that each group is a single longitudinal bar for purpose of determining the pitch and diameter of the transverse reinforcement in accordance with 26.5.3.2. The diameter of such transverse

reinforcement need not, however, exceed 20 mm (see Fig. 11).

c) Pitch and diameter of lateral ties

- 1) *Pitch*—The pitch of transverse reinforcement shall be not more than the least of the following distances:
 - i) The least lateral dimension of the compression members;
 - ii) Sixteen times the smallest diameter of the longitudinal reinforcement bar to be tied; and
 - iii) 300 mm.
- 2) *Diameter*—The diameter of the polygonal links or lateral ties shall be not less than one-fourth of the diameter of the largest longitudinal bar, and in no case less than 16 mm.

d) Helical reinforcement

- 1) *Pitch*—Helical reinforcement shall be of regular formation with the turns of the helix spaced evenly and its ends shall be anchored properly by providing one and a half extra turns of the spiral bar. Where an increased load on the column on the strength of the helical reinforcement is allowed for, the pitch of helical turns shall be not more than 75 mm, nor more than one-sixth of the core diameter of the column, nor less than 25 mm, nor less than three times the diameter of the steel bar forming the helix. In other cases, the requirements of 26.5.3.2 shall be complied with.
- 2) The diameter of the helical reinforcement shall be in accordance with 26.5.3.2 (c) (2).

26.5.3.3 In columns where longitudinal bars are offset at a splice, the slope of the inclined portion of the bar with the axis of the column shall not exceed 1 in 6, and the portions of the bar above and below the offset shall be parallel to the axis of the column. Adequate horizontal support at the offset bends shall be treated as a matter of design, and shall be provided by metal ties, spirals, or parts of the floor construction. Metal ties or spirals so designed shall be placed near (not more than eight-bar diameters from) the point of bend. The horizontal thrust to be resisted shall be assumed as one and half times the horizontal components of the nominal stress in the inclined portion of the bar. Offset bars shall be bent before they are placed in the forms. Where column faces are offset 75 mm or more, splices of vertical bars adjacent to the offset face shall be made by separate dowels overlapped as specified in 26.2.5.1.

27 EXPANSION JOINTS

27.1 Structures in which marked changes in plan dimensions take place abruptly shall be provided with expansion joints at the section where such changes occur. Expansion joints shall be so provided that the necessary movement occurs with a minimum resistance at the joint. The structures adjacent to the joint should preferably be supported on separate columns or walls but not necessarily on separate foundations. Reinforcement shall not extend across an expansion joint and the break between the sections shall be complete.

27.2 The details as to the length of a structure where expansion joints have to be provided can be determined after taking into consideration various factors, such as temperature, exposure to weather, the time and season of the laying of the concrete, etc. Normally structures exceeding 45 m in length are designed with one or more expansion joints. However in view of the large number of factors involved in deciding the location, spacing and nature of expansion joints, the provision of expansion joint in reinforced cement concrete structures should be left to the discretion of the designer. IS 3414 gives the design considerations, which need to be examined and provided for.

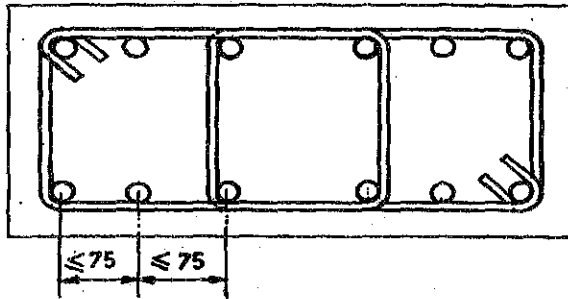

All dimensions in millimetres.

FIG. 8

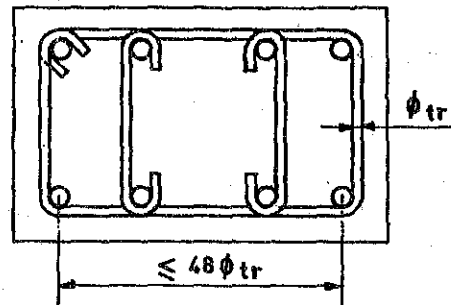

All dimensions in millimetres.

FIG. 9

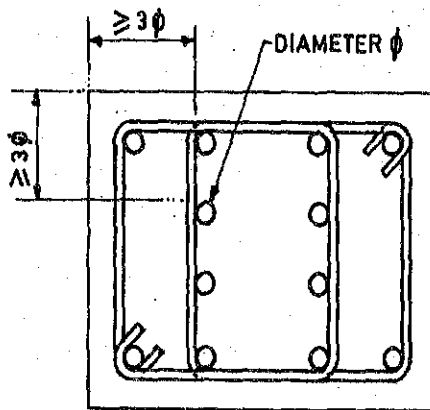

All dimensions in millimetres.

FIG. 10

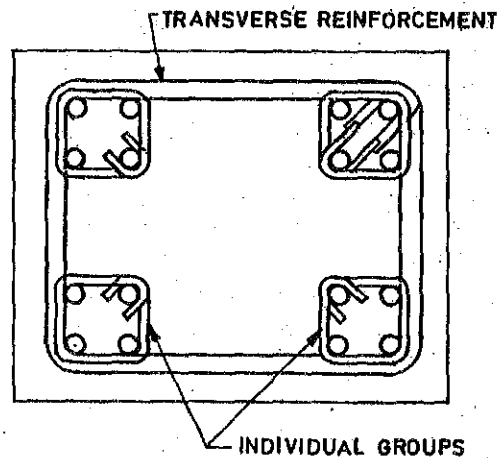

FIG. 11

SECTION 4 SPECIAL DESIGN REQUIREMENTS FOR STRUCTURAL MEMBERS AND SYSTEMS

28 CONCRETE CORBELS

28.1 General

A corbel is a short cantilever projection which supports a load bearing member and where:

- a) the distance a_v between the line of the reaction to the supported load and the root of the corbel is less than d (the effective depth of the root of the corbel); and
- b) the depth at the outer edge of the contact area of the supported load is not less than one-half of the depth at the root of the corbel.

The depth of the corbel at the face of the support is determined in accordance with 40.5.1.

28.2 Design

28.2.1 Simplifying Assumptions

The concrete and reinforcement may be assumed to act as elements of a simple strut-and-tie system, with the following guidelines:

- a) The magnitude of the resistance provided to horizontal force should be not less than one-half of the design vertical load on the corbel (see also 28.2.4).
- b) Compatibility of strains between the strut-and-tie at the corbel root should be ensured.

It should be noted that the horizontal link requirement described in 28.2.3 will ensure satisfactory serviceability performance.

28.2.2 Reinforcement Anchorage

At the front face of the corbel, the reinforcement should be anchored either by:

- a) *welding to a transverse bar of equal strength* — in this case the bearing area of the load should stop short of the face of the support by a distance equal to the cover of the tie reinforcement, or
- b) *bending back the bars to form a loop* — in this case the bearing area of the load should not project beyond the straight portion of the bars forming the main tension reinforcement.

28.2.3 Shear Reinforcement

Shear reinforcement should be provided in the form of horizontal links distributed in the upper two-third of the effective depth of root of the corbel; this reinforcement should be not less than one-half of the area of the main tension reinforcement and should be adequately anchored.

28.2.4 Resistance to Applied Horizontal Force

Additional reinforcement connected to the supported member should be provided to transmit this force in its entirety.

29 DEEP BEAMS

29.1 General

- a) A beam shall be deemed to be a deep beam when the ratio of effective span to overall depth, $\frac{l}{D}$ is less than:
 - 1) 2.0 for a simply supported beam; and
 - 2) 2.5 for a continuous beam.
- b) A deep beam complying with the requirements of 29.2 and 29.3 shall be deemed to satisfy the provisions for shear.

29.2 Lever Arm

The lever arm z for a deep beam shall be determined as below:

- a) For simply supported beams:

$$z = 0.2(l + 2D) \quad \text{when } 1 \leq \frac{l}{D} \leq 2$$

or

$$z = 0.6l \quad \text{when } \frac{l}{D} < 1$$

- b) For continuous beams:

$$z = 0.2(l + 1.5D) \quad \text{when } 1 \leq \frac{l}{D} \leq 2.5$$

or

$$z = 0.5l \quad \text{when } \frac{l}{D} < 1$$

where l is the effective span taken as centre to centre distance between supports or 1.15 times the clear span, whichever is smaller, and D is the overall depth.

29.3 Reinforcement

29.3.1 Positive Reinforcement

The tensile reinforcement required to resist positive bending moment in any span of a deep beam shall:

- a) extend without curtailment between supports;
- b) be embedded beyond the face of each support, so that at the face of the support it shall have a development length not less than $0.8L_d$; where L_d is the development length (see 26.2.1), for the design stress in the reinforcement; and

- c) be placed within a zone of depth equal to $0.25 D - 0.05 l$ adjacent to the tension face of the beam where D is the overall depth and l is the effective span.

29.3.2 Negative Reinforcement

- a) *Termination of reinforcement* — For tensile reinforcement required to resist negative bending moment over a support of a deep beam:

- 1) It shall be permissible to terminate not more than half of the reinforcement at a distance of $0.5 D$ from the face of the support where D is as defined in 29.2; and
- 2) The remainder shall extend over the full span.

- b) *Distribution*—When ratio of clear span to overall depth is in the range 1.0 to 2.5, tensile reinforcement over a support of a deep beam shall be placed in two zones comprising:

- 1) a zone of depth $0.2 D$, adjacent to the tension face, which shall contain a proportion of the tension steel given by

$$0.5 \left(\frac{l}{D} - 0.5 \right)$$

where

l = clear span, and

D = overall depth.

- 2) a zone measuring $0.3 D$ on either side of the mid-depth of the beam, which shall contain the remainder of the tension steel, evenly distributed.

For span to depth ratios less than unity, the steel shall be evenly distributed over a depth of $0.8 D$ measured from the tension face.

29.3.3 Vertical Reinforcement

If forces are applied to a deep beam in such a way that hanging action is required, bars or suspension stirrups shall be provided to carry all the forces concerned.

29.3.4 Side Face Reinforcement

Side face reinforcement shall comply with requirements of minimum reinforcement of walls (see 32.4).

30 RIBBED, HOLLOW BLOCK OR VOIDED SLAB

30.1 General

This covers the slabs constructed in one of the ways described below:

- a) As a series of concrete ribs with topping cast on forms which may be removed after the concrete has set;
- b) As a series of concrete ribs between precast blocks which remain part of the completed

structure; the top of the ribs may be connected by a topping of concrete of the same strength as that used in the ribs; and

- c) With a continuous top and bottom face but containing voids of rectangular, oval or other shape.

30.2 Analysis of Structure

The moments and forces due to design loads on continuous slabs may be obtained by the methods given in Section 3 for solid slabs. Alternatively, the slabs may be designed as a series of simply supported spans provided they are not exposed to weather or corrosive conditions; wide cracks may develop at the supports and the engineer shall satisfy himself that these will not impair finishes or lead to corrosion of the reinforcement.

30.3 Shear

Where hollow blocks are used, for the purpose of calculating shear stress, the rib width may be increased to take account of the wall thickness of the block on one side of the rib; with narrow precast units, the width of the jointing mortar or concrete may be included.

30.4 Deflection

The recommendations for deflection in respect of solid slabs may be applied to ribbed, hollow block or voided construction. The span to effective depth ratios given in 23.2 for a flanged beam are applicable but when calculating the final reduction factor for web width, the rib width for hollow block slabs may be assumed to include the walls of the blocks on both sides of the rib. For voided slabs and slabs constructed of box or I-section units, an effective rib width shall be calculated assuming all material below the upper flange of the unit to be concentrated in a rectangular rib having the same cross-sectional area and depth.

30.5 Size and Position of Ribs

In-situ ribs shall be not less than 65 mm wide. They shall be spaced at centres not greater than 1.5 m apart and their depth, excluding any topping, shall be not more than four times their width. Generally ribs shall be formed along each edge parallel to the span of one way slabs. When the edge is built into a wall or rests on a beam, a rib at least as wide as the bearing shall be formed along the edge.

30.6 Hollow Blocks and Formers

Blocks and formers may be of any suitable material. Hollow clay tiles for the filler type shall conform to IS 3951 (Part 1). When required to contribute to the

structural strength of a slab they shall:

- a) be made of concrete or burnt clay; and
- b) have a crushing strength of at least 14 N/mm^2 measured on the net section when axially loaded in the direction of compressive stress in the slab.

30.7 Arrangement of Reinforcement

The recommendations given in 26.3 regarding maximum distance between bars apply to areas of solid concrete in this form of construction. The curtailment, anchorage and cover to reinforcement shall be as described below:

- a) At least 50 percent of the total main reinforcement shall be carried through at the bottom on to the bearing and anchored in accordance with 26.2.3.3.
- b) Where a slab, which is continuous over supports, has been designed as simply supported, reinforcement shall be provided over the support to control cracking. This reinforcement shall have a cross-sectional area of not less than one-quarter that required in the middle of the adjoining spans and shall extend at least one-tenth of the clear span into adjoining spans.
- c) In slabs with permanent blocks, the side cover to the reinforcement shall not be less than 10 mm. In all other cases, cover shall be provided according to 26.4.

30.8 Precasts Joists and Hollow Filler Blocks

The construction with precast joists and hollow concrete filler blocks shall conform to IS 6061 (Part 1) and precast joist and hollow clay filler blocks shall conform to IS 6061 (Part 2).

31 FLAT SLABS

31.1 General

The term flat slab means a reinforced concrete slab with or without drops, supported generally without beams, by columns with or without flared column heads (see Fig. 12). A flat slab may be solid slab or may have recesses formed on the soffit so that the soffit comprises a series of ribs in two directions. The recesses may be formed by removable or permanent filler blocks.

31.1.1 For the purpose of this clause, the following definitions shall apply:

- a) *Column strip* — Column strip means a design strip having a width of $0.25 l_2$, but not greater than $0.25 l_1$ on each side of the column centre-line, where l_1 is the span in the direction moments are being determined, measured centre to centre of supports and l_2 is the span transverse

to l_1 , measured centre to centre of supports.

- b) *Middle strip* — Middle strip means a design strip bounded on each of its opposite sides by the column strip.
- c) *Panel* — Panel means that part of a slab bounded on each of its four sides by the centre-line of a column or centre-lines of adjacent spans.

31.2 Proportioning

31.2.1 Thickness of Flat Slab

The thickness of the flat slab shall be generally controlled by considerations of span to effective depth ratios given in 23.2.

For slabs with drops conforming to 31.2.2, span to effective depth ratios given in 23.2 shall be applied directly; otherwise the span to effective depth ratios obtained in accordance with provisions in 23.2 shall be multiplied by 0.9. For this purpose, the longer span shall be considered. The minimum thickness of slab shall be 125 mm.

31.2.2 Drop

The drops when provided shall be rectangular in plan, and have a length in each direction not less than one-third of the panel length in that direction. For exterior panels, the width of drops at right angles to the non-continuous edge and measured from the centre-line of the columns shall be equal to one-half the width of drop for interior panels.

31.2.3 Column Heads

Where column heads are provided, that portion of a column head which lies within the largest right circular cone or pyramid that has a vertex angle of 90° and can be included entirely within the outlines of the column and the column head, shall be considered for design purposes (see Fig. 12).

31.3 Determination of Bending Moment

31.3.1 Methods of Analysis and Design

It shall be permissible to design the slab system by one of the following methods:

- a) The direct design method as specified in 31.4, and
- b) The equivalent frame method as specified in 31.5.

In each case the applicable limitations given in 31.4 and 31.5 shall be met.

31.3.2 Bending Moments in Panels with Marginal Beams or Walls

Where the slab is supported by a marginal beam with a depth greater than 1.5 times the thickness of the slab, or by a wall, then:

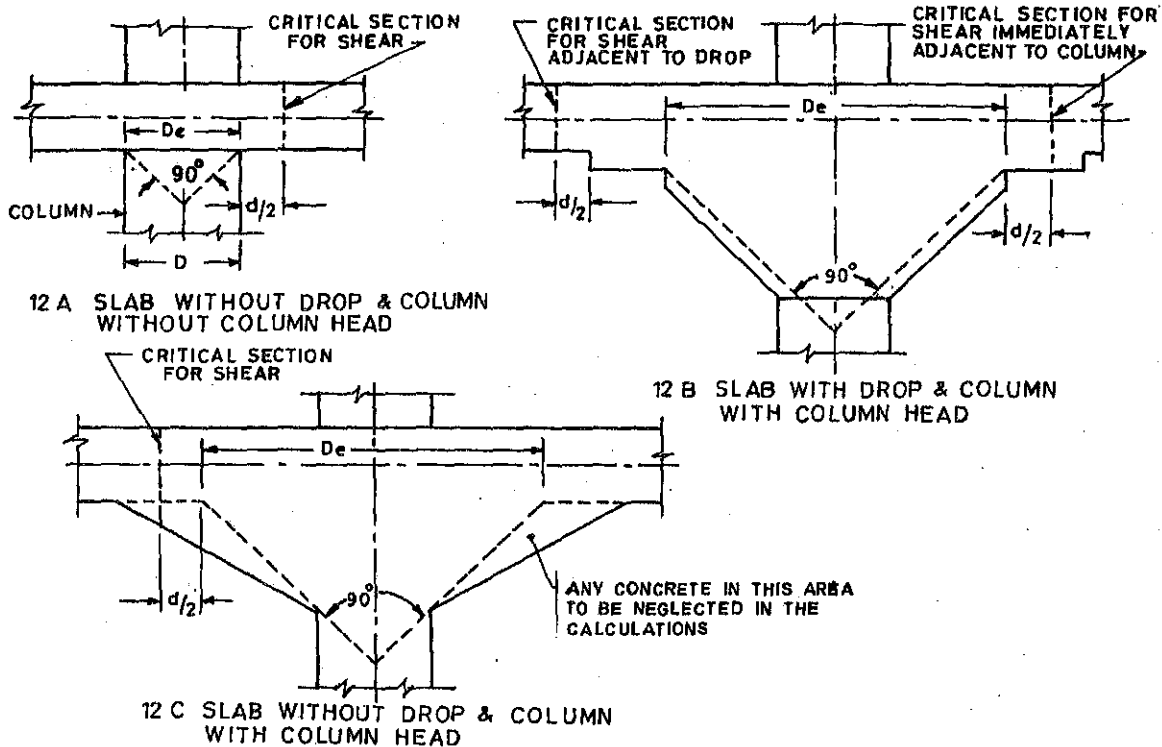

NOTE — D_c is the diameter of column or column head to be considered for design and d is effective depth of slab or drop as appropriate.

FIG. 12 CRITICAL SECTIONS FOR SHEAR IN FLAT SLABS

- a) the total load to be carried by the beam or wall shall comprise those loads directly on the wall or beam plus a uniformly distributed load equal to one-quarter of the total load on the slab, and
- b) the bending moments on the half-column strip adjacent to the beam or wall shall be one-quarter of the bending moments for the first interior column strip.

31.3.3 Transfer of Bending Moments to Columns

When unbalanced gravity load, wind, earthquake, or other lateral loads cause transfer of bending moment between slab and column, the flexural stresses shall be investigated using a fraction, α of the moment given by:

$$\alpha = \frac{1}{1 + \frac{2}{3} \sqrt{a_1/a_2}}$$

where

- a_1 = overall dimension of the critical section for shear in the direction in which moment acts, and
- a_2 = overall dimension of the critical section for shear transverse to the direction in which moment acts.

A slab width between lines that are one and one-half slab or drop panel thickness; $1.5 D$, on each side of the column or capital may be considered effective, D being the size of the column.

Concentration of reinforcement over column head by closer spacing or additional reinforcement may be used to resist the moment on this section.

31.4 Direct Design Method

31.4.1 Limitations

Slab system designed by the direct design method shall fulfil the following conditions:

- a) There shall be minimum of three continuous spans in each direction,
- b) The panels shall be rectangular, and the ratio of the longer span to the shorter span within a panel shall not be greater than 2.0,
- c) It shall be permissible to offset columns to a maximum of 10 percent of the span in the direction of the offset notwithstanding the provision in (b),
- d) The successive span lengths in each direction shall not differ by more than one-third of the longer span. The end spans may be shorter but not longer than the interior spans, and

- e) The design live load shall not exceed three times the design dead load.

31.4.2 Total Design Moment for a Span

31.4.2.1 In the direct design method, the total design moment for a span shall be determined for a strip bounded laterally by the centre-line of the panel on each side of the centre-line of the supports.

31.4.2.2 The absolute sum of the positive and average negative bending moments in each direction shall be taken as:

$$M_o = \frac{Wl_n}{8}$$

where

M_o = total moment;

W = design load on an area $l_2 l_n$;

l_n = clear span extending from face to face of columns, capitals, brackets or walls, but not less than $0.65 l_1$;

l_1 = length of span in the direction of M_o ; and

l_2 = length of span transverse to l_1 .

31.4.2.3 Circular supports shall be treated as square supports having the same area.

31.4.2.4 When the transverse span of the panels on either side of the centre-line of supports varies, l_2 shall be taken as the average of the transverse spans.

31.4.2.5 When the span adjacent and parallel to an edge is being considered, the distance from the edge to the centre-line of the panel shall be substituted for l_2 in 31.4.2.2.

31.4.3 Negative and Positive Design Moments

31.4.3.1 The negative design moment shall be located at the face of rectangular supports, circular supports being treated as square supports having the same area.

31.4.3.2 In an interior span, the total design moment M_o shall be distributed in the following proportions:

Negative design moment 0.65

Positive design moment 0.35

31.4.3.3 In an end span, the total design moment M_o shall be distributed in the following proportions:

Interior negative design moment:

$$0.75 - \frac{0.10}{1 + \frac{1}{\alpha_c}}$$

Positive design moment:

$$0.63 - \frac{0.28}{1 + \frac{1}{\alpha_c}}$$

Exterior negative design moment:

$$\frac{0.65}{1 + \frac{1}{\alpha_c}}$$

α_c is the ratio of flexural stiffness of the exterior columns to the flexural stiffness of the slab at a joint taken in the direction moments are being determined and is given by

$$\alpha_c = \frac{\Sigma K_c}{K_s}$$

where

K_c = sum of the flexural stiffness of the columns meeting at the joint; and

K_s = flexural stiffness of the slab, expressed as moment per unit rotation.

31.4.3.4 It shall be permissible to modify these design moments by up to 10 percent, so long as the total design moment, M_o for the panel in the direction considered is not less than that required by 31.4.2.2.

31.4.3.5 The negative moment section shall be designed to resist the larger of the two interior negative design moments determined for the spans framing into a common support unless an analysis is made to distribute the unbalanced moment in accordance with the stiffness of the adjoining parts.

31.4.4 Distribution of Bending Moments Across the Panel Width

Bending moments at critical cross-section shall be distributed to the column strips and middle strips as specified in 31.5.5 as applicable.

31.4.5 Moments in Columns

31.4.5.1 Columns built integrally with the slab system shall be designed to resist moments arising from loads on the slab system.

31.4.5.2 At an interior support, the supporting members above and below the slab shall be designed to resist the moment M given by the following equation, in direct proportion to their stiffnesses unless a general analysis is made:

$$M = 0.08 \frac{(w_d + 0.5w_l)l_2 l_n^2 - w_d' l_2' l_n'^2}{1 + \frac{1}{\alpha_c}}$$

where

w_d, w_l = design dead and live loads respectively, per unit area;

l_2 = length of span transverse to the direction of M ;

l_n = length of the clear span in the direction of M , measured face to face of supports;

$\alpha_c = \frac{\sum K_c}{\sum K_s}$ where K_c and K_s are as defined in 31.4.3.3; and

w'_d, l'_2 and l'_n , refer to the shorter span.

31.4.6 Effects of Pattern Loading

In the direct design method, when the ratio of live load to dead load exceeds 0.5 :

- the sum of the flexural stiffnesses of the columns above and below the slab, $\sum K_c$, shall be such that α_c is not less than the appropriate minimum value $\alpha_{c\min}$ specified in Table 17, or
- if the sum of the flexural stiffnesses of the columns, $\sum K_c$, does not satisfy (a), the positive design moments for the panel shall be multiplied by the coefficient β_s given by the following equation:

$$\beta_s = 1 + \left(\frac{2 - \frac{w_d}{w_l}}{4 + \frac{w_d}{w_l}} \right) \left(1 - \frac{\alpha_c}{\alpha_{c\min}} \right)$$

α_c is the ratio of flexural stiffness of the columns above and below the slab to the flexural stiffness of the slabs at a joint taken in the direction moments are being determined and is given by:

$$\alpha_c = \frac{\sum K_c}{\sum K_s}$$

where K_c and K_s are flexural stiffnesses of column and slab respectively.

31.5 Equivalent Frame Method

31.5.1 Assumptions

The bending moments and shear forces may be determined by an analysis of the structure as a continuous frame and the following assumptions may be made:

- The structure shall be considered to be made up of equivalent frames on column lines taken longitudinally and transversely through the building. Each frame consists of a row of equivalent columns or supports, bounded laterally by the centre-line of the panel on each side of the centre-line of the columns or supports. Frames adjacent and parallel to an edge shall be bounded by the edge and the centre-line of the adjacent panel.

- Each such frame may be analyzed in its entirety, or, for vertical loading, each floor thereof and the roof may be analyzed separately with its columns being assumed fixed at their remote ends. Where slabs are thus analyzed separately, it may be assumed in determining the bending moment at a given support that the slab is fixed at any support two panels distant therefrom provided the slab continues beyond the point.
- For the purpose of determining relative stiffness of members, the moment of inertia of any slab or column may be assumed to be that of the gross cross-section of the concrete alone.
- Variations of moment of inertia along the axis of the slab on account of provision of drops shall be taken into account. In the case of recessed or coffered slab which is made solid in the region of the columns, the stiffening effect may be ignored provided the solid part of the slab does not extend more than $0.15 l_{ef}$ into the span measured from the centre-line of the columns. The stiffening effect of flared column heads may be ignored.

31.5.2 Loading Pattern

31.5.2.1 When the loading pattern is known, the structure shall be analyzed for the load concerned.

Table 17 Minimum Permissible Values of α_c
(Clause 31.4.6)

Imposed Load/Dead Load	Ratio $\frac{l_2}{l_1}$	Value of $\alpha_{c\min}$
(1)	(2)	(3)
0.5	0.5 to 2.0	0
1.0	0.5	0.6
1.0	0.8	0.7
1.0	1.0	0.7
1.0	1.25	0.8
1.0	2.0	1.2
2.0	0.5	1.3
2.0	0.8	1.5
2.0	1.0	1.6
2.0	1.25	1.9
2.0	2.0	4.9
3.0	0.5	1.8
3.0	0.8	2.0
3.0	1.0	2.3
3.0	1.25	2.8
3.0	2.0	13.0

31.5.2.2 When the live load is variable but does not exceed three-quarters of the dead load, or the nature of the live load is such that all panels will be loaded simultaneously, the maximum moments may be assumed to occur at all sections when full design live load is on the entire slab system.

31.5.2.3 For other conditions of live load/dead load ratio and when all panels are not loaded simultaneously:

- a) maximum positive moment near midspan of a panel may be assumed to occur when three-quarters of the full design live load is on the panel and on alternate panels; and
- b) maximum negative moment in the slab at a support may be assumed to occur when three-quarters of the full design live load is on the adjacent panels only.

31.5.2.4 In no case shall design moments be taken to be less than those occurring with full design live load on all panels.

31.5.3 Negative Design Moment

31.5.3.1 At interior supports, the critical section for negative moment, in both the column strip and middle strip, shall be taken at the face of rectilinear supports, but in no case at a distance greater than $0.175 l_1$ from the centre of the column where l_1 is the length of the span in the direction moments are being determined, measured centre-to-centre of supports.

31.5.3.2 At exterior supports provided with brackets or capitals, the critical section for negative moment in the direction perpendicular to the edge shall be taken at a distance from the face of the supporting element not greater than one-half the projection of the bracket or capital beyond the face of the supporting element.

31.5.3.3 Circular or regular polygon shaped supports shall be treated as square supports having the same area.

31.5.4 Modification of Maximum Moment

Moments determined by means of the equivalent frame method, for slabs which fulfil the limitations of 31.4 may be reduced in such proportion that the numerical sum of the positive and average negative moments is not less than the value of total design moment M_0 specified in 31.4.2.2.

31.5.5 Distribution of Bending Moment Across the Panel Width

31.5.5.1 Column strip : Negative moment at an interior support

At an interior support, the column strip shall be designed to resist 75 percent of the total negative moment in the panel at that support.

31.5.5.2 Column strip : Negative moment at an exterior support

- a) At an exterior support, the column strip shall be designed to resist the total negative moment in the panel at that support.
- b) Where the exterior support consists of a column or a wall extending for a distance equal to or

greater than three-quarters of the value of l_2 , the length of span transverse to the direction moments are being determined, the exterior negative moment shall be considered to be uniformly distributed across the length l_2 .

31.5.5.3 Column strip : Positive moment for each span

For each span, the column strip shall be designed to resist 60 percent of the total positive moment in the panel.

31.5.5.4 Moments in the middle strip

The middle strip shall be designed on the following bases:

- a) That portion of the design moment not resisted by the column strip shall be assigned to the adjacent middle strips.
- b) Each middle strip shall be proportioned to resist the sum of the moments assigned to its two half middle strips.
- c) The middle strip adjacent and parallel to an edge supported by a wall shall be proportioned to resist twice the moment assigned to half the middle strip corresponding to the first row of interior columns.

31.6 Shear in Flat Slab

31.6.1 The critical section for shear shall be at a distance $d/2$ from the periphery of the column/capital/drop panel, perpendicular to the plane of the slab where d is the effective depth of the section (see Fig. 12). The shape in plan is geometrically similar to the support immediately below the slab (see Fig. 13A and 13B).

NOTE—For column sections with re-entrant angles, the critical section shall be taken as indicated in Fig. 13C and 13D.

31.6.1.1 In the case of columns near the free edge of a slab, the critical section shall be taken as shown in Fig. 14.

31.6.1.2 When openings in flat slabs are located at a distance less than ten times the thickness of the slab from a concentrated reaction or when the openings are located within the column strips, the critical sections specified in 31.6.1 shall be modified so that the part of the periphery of the critical section which is enclosed by radial projections of the openings to the centroid of the reaction area shall be considered ineffective (see Fig. 15), and openings shall not encroach upon column head.

31.6.2 Calculation of Shear Stress

The shear stress τ_v shall be the sum of the values calculated according to 31.6.2.1 and 31.6.2.2.

31.6.2.1 The nominal shear stress in flat slabs shall be taken as V/b_0d where V is the shear force due to design load, b_0 is the periphery of the critical section and d is the effective depth.

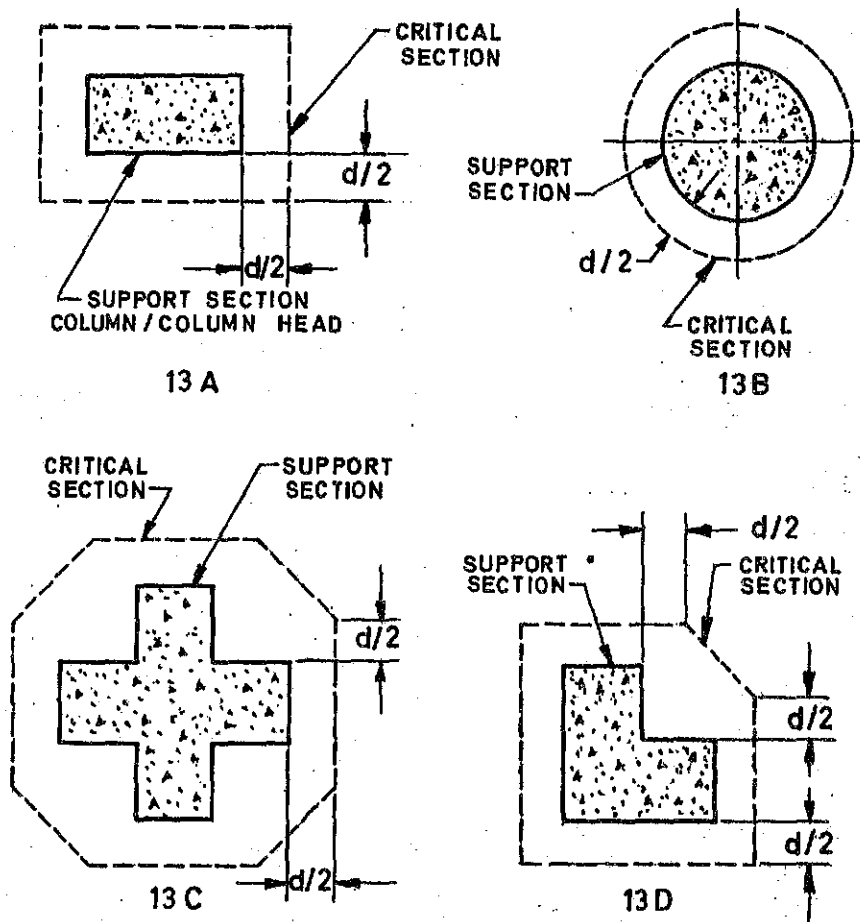

NOTE — d is the effective depth of the flat slab/drop.

FIG. 13 CRITICAL SECTIONS IN PLAN FOR SHEAR IN FLAT SLABS

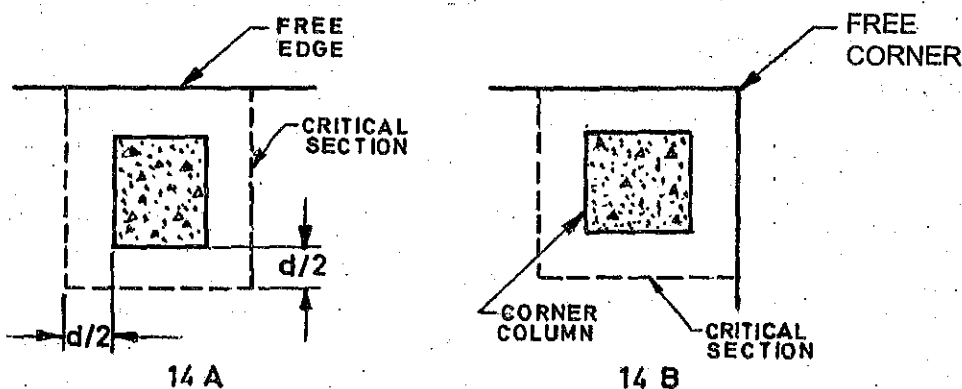

FIG. 14 EFFECT OF FREE EDGES ON CRITICAL SECTION FOR SHEAR

31.6.2.2 When unbalanced gravity load, wind, earthquake or other forces cause transfer of bending moment between slab and column, a fraction $(1 - \alpha)$ of the moment shall be considered transferred by eccentricity of the shear about the centroid of the critical section. Shear stresses shall be taken as varying linearly about the centroid of the critical section. The

value of α shall be obtained from the equation given in 31.3.3.

31.6.3 Permissible Shear Stress

31.6.3.1 When shear reinforcement is not provided, the calculated shear stress at the critical section shall not exceed $k_s \tau_c$.

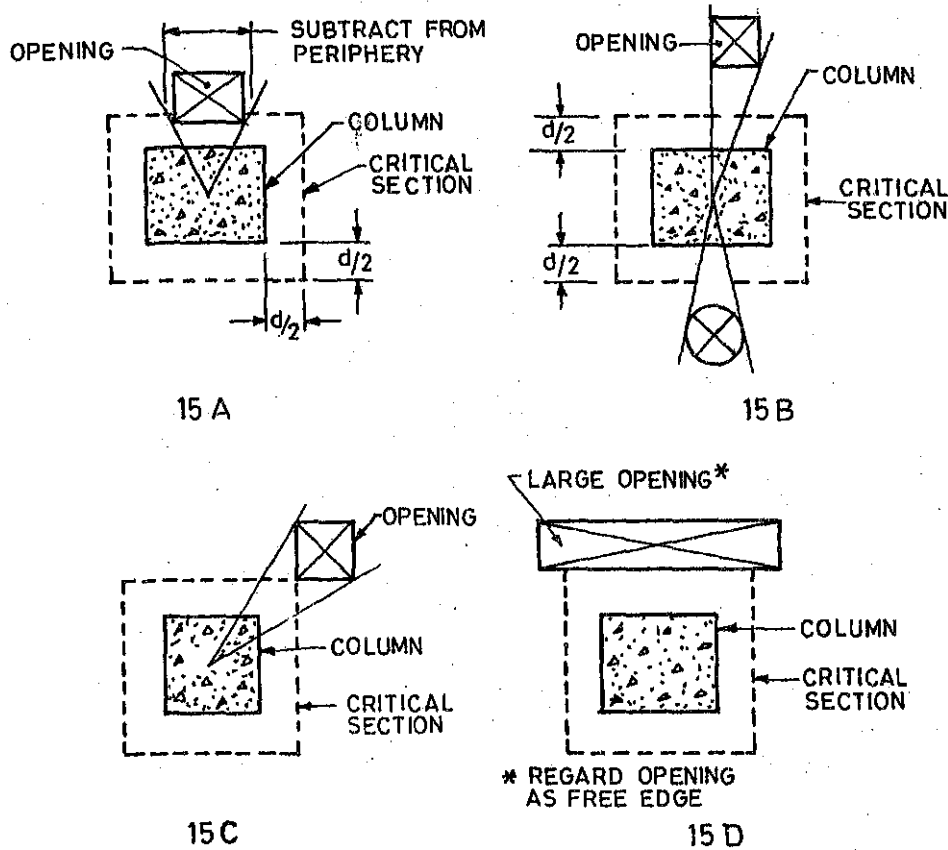

FIG. 15 EFFECT OF OPENINGS ON CRITICAL SECTION FOR SHEAR

where

$k_s = (0.5 + \beta_c)$ but not greater than 1, β_c being the ratio of short side to long side of the column/capital; and

$\tau_c = 0.25 \sqrt{f_{ck}}$ in limit state method of design,
and $0.16 \sqrt{f_{ck}}$ in working stress method of design.

31.6.3.2 When the shear stress at the critical section exceeds the value given in 31.6.3.1, but less than $1.5 \tau_c$ shear reinforcement shall be provided. If the shear stress exceeds $1.5 \tau_c$, the flat slab shall be redesigned. Shear stresses shall be investigated at successive sections more distant from the support and shear reinforcement shall be provided up to a section where the shear stress does not exceed $0.5 \tau_c$. While designing the shear reinforcement, the shear stress carried by the concrete shall be assumed to be $0.5 \tau_c$ and reinforcement shall carry the remaining shear.

31.7 Slab Reinforcement

31.7.1 Spacing

The spacing of bars in a flat slab, shall not exceed

2 times the slab thickness, except where a slab is of cellular or ribbed construction.

31.7.2 Area of Reinforcement

When drop panels are used, the thickness of drop panel for determination of area of reinforcement shall be the lesser of the following:

- Thickness of drop, and
- Thickness of slab plus one quarter the distance between edge of drop and edge of capital.

31.7.3 Minimum Length of Reinforcement

- Reinforcement in flat slabs shall have the minimum lengths specified in Fig.16. Larger lengths of reinforcement shall be provided when required by analysis.
- Where adjacent spans are unequal, the extension of negative reinforcement beyond each face of the common column shall be based on the longer span.
- The length of reinforcement for slabs in frames not braced against sideways and for slabs resisting lateral loads shall be determined by analysis but shall not be less than those prescribed in Fig. 16.

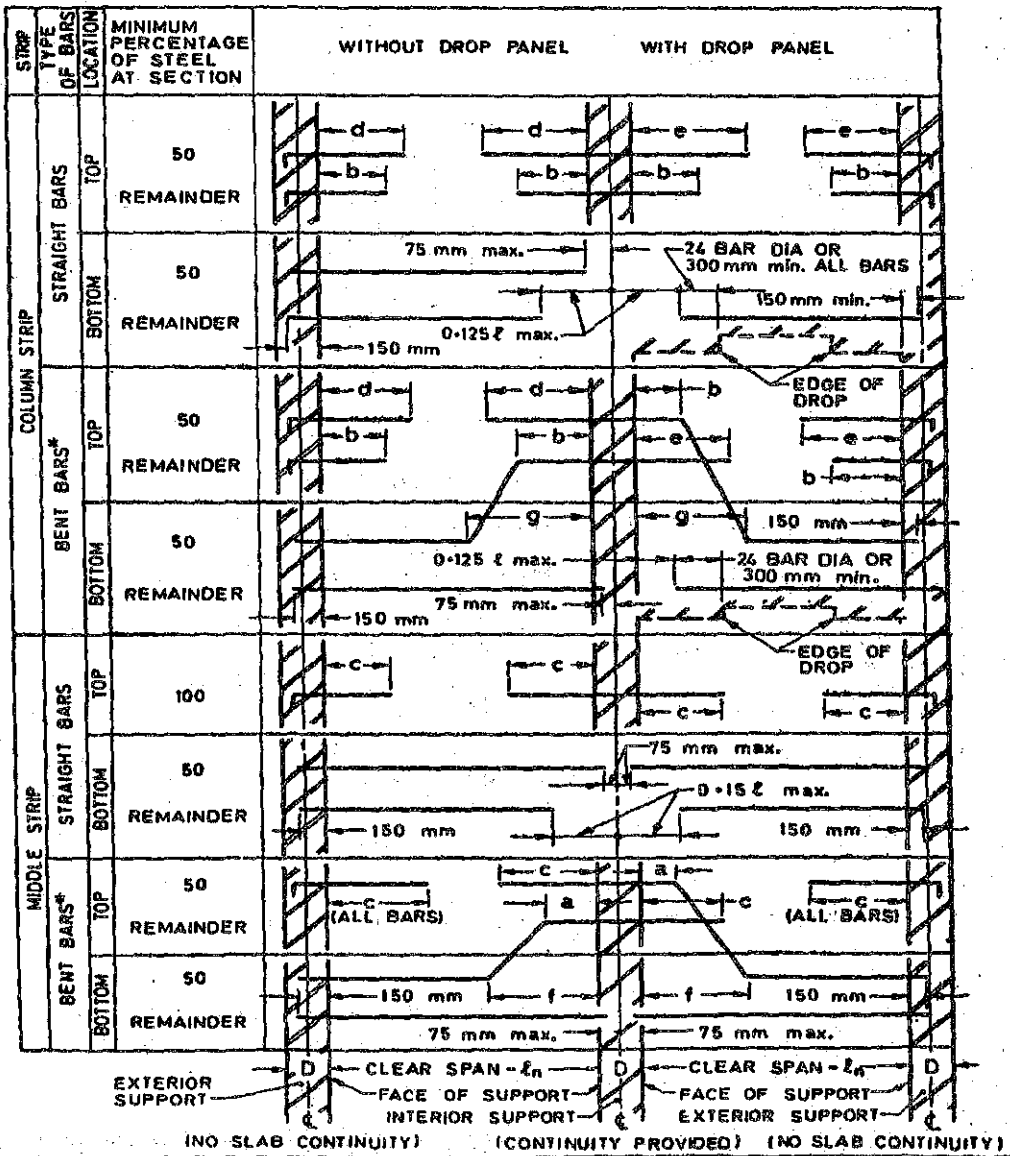

Bar Length from Face of Support							
Minimum Length				Maximum Length			
Mark	a	b	c	d	e	f	g
Length	$0.14 l_n$	$0.20 l_n$	$0.22 l_n$	$0.30 l_n$	$0.33 l_n$	$0.20 l_n$	$0.24 l_n$

* Bent bars at exterior supports may be used if a general analysis is made.

NOTE — D is the diameter of the column and the dimension of the rectangular column in the direction under consideration.

FIG. 16 MINIMUM BEND JOINT LOCATIONS AND EXTENSIONS FOR REINFORCEMENT IN FLAT SLABS

31.7.4 Anchoring Reinforcement

- a) All slab reinforcement perpendicular to a discontinuous edge shall have an anchorage (straight, bent or otherwise anchored) past the internal face of the spandrel beam, wall or column, of an amount:
- 1) *For positive reinforcement* — not less than 150 mm except that with fabric reinforcement having a fully welded transverse wire directly over the support, it shall be permissible to reduce this length to one-half of the width of the support or 50 mm, whichever is greater; and
 - 2) *For negative reinforcement* — such that the design stress is developed at the internal face, in accordance with Section 3.
- b) Where the slab is not supported by a spandrel beam or wall, or where the slab cantilevers beyond the support, the anchorage shall be obtained within the slab.

31.8 Openings in Flat Slabs

Openings of any size may be provided in the flat slab if it is shown by analysis that the requirements of strength and serviceability are met. However, for openings conforming to the following, no special analysis is required.

- a) Openings of any size may be placed within the middle half of the span in each direction, provided the total amount of reinforcement required for the panel without the opening is maintained.
- b) In the area common to two column strips, not more than one-eighth of the width of strip in either span shall be interrupted by the openings. The equivalent of reinforcement interrupted shall be added on all sides of the openings.
- c) In the area common to one column strip and one middle strip, not more than one-quarter of the reinforcement in either strip shall be interrupted by the openings. The equivalent of reinforcement interrupted shall be added on all sides of the openings.
- d) The shear requirements of 31.6 shall be satisfied.

32 WALLS

32.1 General

Reinforced concrete walls subjected to direct compression or combined flexure and direct compression should be designed in accordance with Section 5 or Annex B provided the vertical reinforcement is provided in each face. Braced walls subjected to only vertical compression may be designed

as per empirical procedure given in 32.2. The minimum thickness of walls shall be 100 mm.

32.1.1 Guidelines or design of walls subjected to horizontal and vertical loads are given in 32.3.

32.2 Empirical Design Method for Walls Subjected to Inplane Vertical Loads

32.2.1 Braced Walls

Walls shall be assumed to be braced if they are laterally supported by a structure in which all the following apply:

- a) Walls or vertical braced elements are arranged in two directions so as to provide lateral stability to the structure as a whole.
- b) Lateral forces are resisted by shear in the planes of these walls or by braced elements.
- c) Floor and roof systems are designed to transfer lateral forces.
- d) Connections between the wall and the lateral supports are designed to resist a horizontal force not less than
 - 1) the simple static reactions to the total applied horizontal forces at the level of lateral support; and
 - 2) 2.5 percent of the total vertical load that the wall is designed to carry at the level of lateral support.

32.2.2 Eccentricity of Vertical Load

The design of a wall shall take account of the actual eccentricity of the vertical force subject to a minimum value of $0.05 t$.

The vertical load transmitted to a wall by a discontinuous concrete floor or roof shall be assumed to act at one-third the depth of the bearing area measured from the span face of the wall. Where there is an *in-situ* concrete floor continuous over the wall, the load shall be assumed to act at the centre of the wall.

The resultant eccentricity of the total vertical load on a braced wall at any level between horizontal lateral supports, shall be calculated on the assumption that the resultant eccentricity of all the vertical loads above the upper support is zero.

32.2.3 Maximum Effective Height to Thickness Ratio

The ratio of effective height to thickness, H_{we}/t shall not exceed 30.

32.2.4 Effective Height

The effective height of a braced wall shall be taken as follows:

- a) Where restrained against rotation at both ends by

- 1) floors $0.75 H_w$ or
 2) intersecting walls or similar members $0.75 L_1$ whichever is the lesser.
- b) Where not restrained against rotation at both ends by
- 1) floors $1.0 H_w$ or
 2) intersecting walls or similar members $1.0 L_1$ whichever is the lesser.

where

- H_w = the unsupported height of the wall.
 L_1 = the horizontal distance between centres of lateral restraint.

32.2.5 Design Axial Strength of Wall

The design axial strength P_{uw} per unit length of a braced wall in compression may be calculated from the following equation:

$$P_{uw} = 0.3 (t - 1.2 e - 2e_n) f_{ck}$$

where

- t = thickness of the wall,
 e = eccentricity of load measured at right angles to the plane of the wall determined in accordance with 32.2.2, and
 e_n = additional eccentricity due to slenderness effect taken as $H_w / 2500 t$.

32.3 Walls Subjected to Combined Horizontal and Vertical Forces

32.3.1 When horizontal forces are in the plane of the wall, it may be designed for vertical forces in accordance with 32.2 and for horizontal shear in accordance with 32.3. In plane bending may be neglected in case a horizontal cross-section of the wall is always under compression due to combined effect of horizontal and vertical loads.

32.3.2 Walls subjected to horizontal forces perpendicular to the wall and for which the design axial load does not exceed $0.04 f_{ck} A_g$, shall be designed as slabs in accordance with the appropriate provisions under 24, where A_g is gross area of the section.

32.4 Design for Horizontal Shear

32.4.1 Critical Section for Shear

The critical section for maximum shear shall be taken at a distance from the base of $0.5 L_w$ or $0.5 H_w$ whichever is less.

32.4.2 Nominal Shear Stress

The nominal shear stress τ_{vw} in walls shall be obtained as follows:

$$\tau_{vw} = V_u / t.d$$

where

- V_u = shear force due to design loads.
 t = wall thickness.
 d = $0.8 \times L_w$ where L_w is the length of the wall.

32.4.2.1 Under no circumstances shall the nominal shear stress τ_{vw} in walls exceed $0.17 f_{ck}$ in limit state method and $0.12 f_{ck}$ in working stress method.

32.4.3 Design Shear Strength of Concrete

The design shear strength of concrete in walls, τ_{cw} , without shear reinforcement shall be taken as below:

- a) For $H_w / L_w \leq 1$

$$\tau_{cw} = (3.0 - H_w / L_w) K_1 \sqrt{f_{ck}}$$

where K_1 is 0.2 in limit state method and 0.13 in working stress method.

- b) For $H_w / L_w > 1$

Lesser of the values calculated from (a) above and from

$$\tau_{cw} = K_2 \sqrt{f_{ck}} \frac{(H_w / L_w + 1)}{(H_w / L_w - 1)}$$

where K_2 is 0.045 in limit state method and 0.03 in working stress method, but shall be not less than $K_3 \sqrt{f_{ck}}$ in any case, where K_3 is 0.15 in limit state method and 0.10 in working stress method.

32.4.4 Design of Shear Reinforcement

Shear reinforcement shall be provided to carry a shear equal to $V_u - \tau_{cw} t (0.8 L_w)$. In case of working stress method V_u is replaced by V . The strength of shear reinforcement shall be calculated as per 40.4 or B-5.4 with A_{sv} defined as below:

$$A_{sv} = P_w (0.8 L_w) t$$

where P_w is determined as follows:

- a) For walls where $H_w / L_w \leq 1$, P_w shall be the lesser of the ratios of either the vertical reinforcement area or the horizontal reinforcement area to the cross-sectional area of wall in the respective direction.
- b) For walls where $H_w / L_w > 1$, P_w shall be the ratio of the horizontal reinforcement area to the cross-sectional area of wall per vertical metre.

32.5 Minimum Requirements for Reinforcement in Walls

The reinforcement for walls shall be provided as below:

- a) the minimum ratio of vertical reinforcement to gross concrete area shall be:
- 1) 0.001 2 for deformed bars not larger than 16 mm in diameter and with a characteristic strength of 415 N/mm² or greater.
 - 2) 0.001 5 for other types of bars.
 - 3) 0.001 2 for welded wire fabric not larger than 16 mm in diameter.
- b) Vertical reinforcement shall be spaced not farther apart than three times the wall thickness nor 450 mm.
- c) The minimum ratio of horizontal reinforcement to gross concrete area shall be:
- 1) 0.002 0 for deformed bars not larger than 16 mm in diameter and with a characteristic strength of 415 N/mm² or greater.
 - 2) 0.002 5 for other types of bars.
 - 3) 0.002 0 for welded wire fabric not larger than 16 mm in diameter.
- d) Horizontal reinforcement shall be spaced not farther apart than three times the wall thickness nor 450 mm.

NOTE — The minimum reinforcement may not always be sufficient to provide adequate resistance to the effects of shrinkage and temperature.

32.5.1 For walls having thickness more than 200 mm, the vertical and horizontal reinforcement shall be provided in two grids, one near each face of the wall.

32.5.2 Vertical reinforcement need not be enclosed by transverse reinforcement as given in 26.5.3.2 for column, if the vertical reinforcement is not greater than 0.01 times the gross sectional area or where the vertical reinforcement is not required for compression.

33 STAIRS

33.1 Effective Span of Stairs

The effective span of stairs without stringer beams shall

be taken as the following horizontal distances:

- a) Where supported at top and bottom risers by beams spanning parallel with the risers, the distance centre-to-centre of beams;
- b) Where spanning on to the edge of a landing slab, which spans parallel, with the risers (*see* Fig. 17), a distance equal to the going of the stairs plus at each end either half the width of the landing or one metre, whichever is smaller; and
- c) Where the landing slab spans in the same direction as the stairs, they shall be considered as acting together to form a single slab and the span determined as the distance centre-to-centre of the supporting beams or walls, the going being measured horizontally.

33.2 Distribution of Loading on Stairs

In the case of stairs with open wells, where spans partly crossing at right angles occur, the load on areas common to any two such spans may be taken as one-half in each direction as shown in Fig. 18. Where flights or landings are embedded into walls for a length of not less than 110 mm and are designed to span in the direction of the flight, a 150 mm strip may be deducted from the loaded area and the effective breadth of the section increased by 75 mm for purposes of design (*see* Fig. 19).

33.3 Depth of Section

The depth of section shall be taken as the minimum thickness perpendicular to the soffit of the staircase.

34 FOOTINGS

34.1 General

Footings shall be designed to sustain the applied loads, moments and forces and the induced reactions and to ensure that any settlement which may occur shall be as nearly uniform as possible, and the safe bearing capacity of the soil is not exceeded (*see* IS 1904).

34.1.1 In sloped or stepped footings the effective

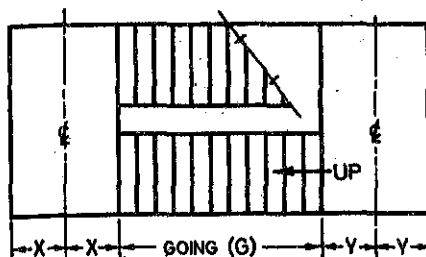

X	Y	SPAN IN METRES
<1 m	<1 m	G + X + Y
<1 m	≥ 1 m	G + X + 1
≥ 1 m	<1 m	G + Y + 1
≥ 1 m	≥ 1 m	G + 1 + 1

FIG. 17 EFFECTIVE SPAN FOR STAIRS, SUPPORTED AT EACH END BY LANDINGS SPANNING PARALLEL WITH THE RISERS

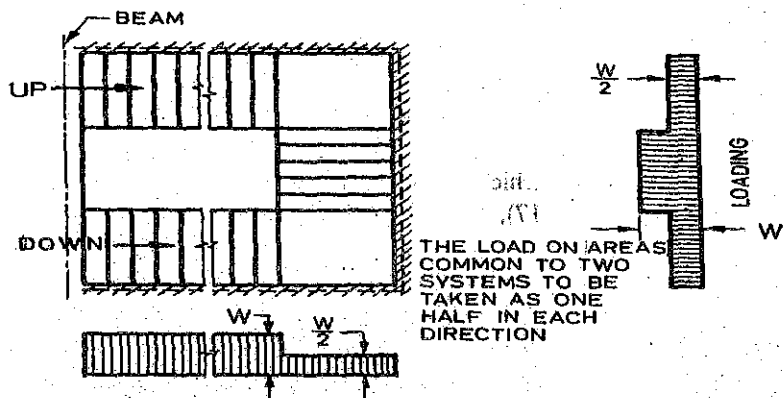

FIG. 18 LOADING ON STAIRS WITH OPEN WELLS

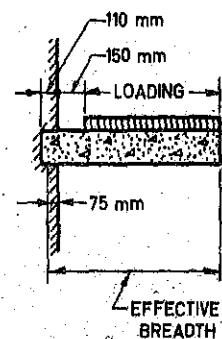

FIG. 19 LOADING ON STAIRS BUILT INTO WALLS

cross-section in compression shall be limited by the area above the neutral plane, and the angle of slope or depth and location of steps shall be such that the design requirements are satisfied at every section. Sloped and stepped footings that are designed as a unit shall be constructed to assure action as a unit.

34.1.2 Thickness at the Edge of Footing

In reinforced and plain concrete footings, the thickness at the edge shall be not less than 150 mm for footings on soils, nor less than 300 mm above the tops of piles for footings on piles.

34.1.3 In the case of plain concrete pedestals, the angle between the plane passing through the bottom edge of the pedestal and the corresponding junction edge of the column with pedestal and the horizontal plane (see Fig. 20) shall be governed by the expression:

$$\tan \alpha \leq 0.9 \sqrt{\frac{100 q_0}{f_{ck}} + 1}$$

where

q_0 = calculated maximum bearing pressure at the base of the pedestal in N/mm^2 , and

f_{ck} = characteristic strength of concrete at 28 days in N/mm^2 .

34.2 Moments and Forces

34.2.1 In the case of footings on piles, computation for moments and shears may be based on the assumption that the reaction from any pile is concentrated at the centre of the pile.

34.2.2 For the purpose of computing stresses in footings which support a round or octagonal concrete column or pedestal, the face of the column or pedestal shall be taken as the side of a square inscribed within the perimeter of the round or octagonal column or pedestal.

34.2.3 Bending Moment

34.2.3.1 The bending moment at any section shall be determined by passing through the section a vertical

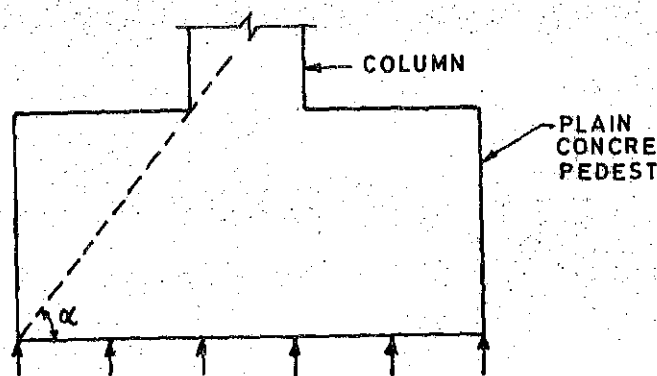

FIG. 20

plane which extends completely across the footing, and computing the moment of the forces acting over the entire area of the footing on one side of the said plane.

34.2.3.2 The greatest bending moment to be used in the design of an isolated concrete footing which supports a column, pedestal or wall, shall be the moment computed in the manner prescribed in **34.2.3.1** at sections located as follows:

- a) At the face of the column, pedestal or wall, for footings supporting a concrete column, pedestal or wall;
- b) Halfway between the centre-line and the edge of the wall, for footings under masonry walls; and
- c) Halfway between the face of the column or pedestal and the edge of the gusseted base, for footings under gusseted bases.

34.2.4 Shear and Bond

34.2.4.1 The shear strength of footings is governed by the more severe of the following two conditions:

- a) The footing acting essentially as a wide beam, with a potential diagonal crack extending in a plane across the entire width; the critical section for this condition shall be assumed as a vertical section located from the face of the column, pedestal or wall at a distance equal to the effective depth of footing for footings on piles.
- b) Two-way action of the footing, with potential diagonal cracking along the surface of truncated cone or pyramid around the concentrated load; in this case, the footing shall be designed for shear in accordance with appropriate provisions specified in **31.6**.

34.2.4.2 In computing the external shear or any section through a footing supported on piles, the entire reaction from any pile of diameter D_p whose centre is located $D_p/2$ or more outside the section shall be assumed as producing shear on the section; the reaction from any pile whose centre is located $D_p/2$ or more inside the section shall be assumed as producing no shear on the section. For intermediate positions of the pile centre, the portion of the pile reaction to be assumed as producing shear on the section shall be based on straight line interpolation between full value at $D_p/2$ outside the section and zero value at $D_p/2$ inside the section.

34.2.4.3 The critical section for checking the development length in a footing shall be assumed at the same planes as those described for bending moment in **34.2.3** and also at all other vertical planes where abrupt changes of section occur. If reinforcement is curtailed, the anchorage requirements shall be checked in accordance with **26.2.3**.

34.3 Tensile Reinforcement

The total tensile reinforcement at any section shall provide a moment of resistance at least equal to the bending moment on the section calculated in accordance with **34.2.3**.

34.3.1 Total tensile reinforcement shall be distributed across the corresponding resisting section as given below:

- a) In one-way reinforced footing, the reinforcement extending in each direction shall be distributed uniformly across the full width of the footing;
- b) In two-way reinforced square footing, the reinforcement extending in each direction shall be distributed uniformly across the full width of the footing; and
- c) In two-way reinforced rectangular footing, the reinforcement in the long direction shall be distributed uniformly across the full width of the footing. For reinforcement in the short direction, a central band equal to the width of the footing shall be marked along the length of the footing and portion of the reinforcement determined in accordance with the equation given below shall be uniformly distributed across the central band:

$$\frac{\text{Reinforcement in central band width}}{\text{Total reinforcement in short direction}} = \frac{2}{\beta + 1}$$

where β is the ratio of the long side to the short side of the footing. The remainder of the reinforcement shall be uniformly distributed in the outer portions of the footing.

34.4 Transfer of Load at the Base of Column

The compressive stress in concrete at the base of a column or pedestal shall be considered as being transferred by bearing to the top of the supporting pedestal or footing. The bearing pressure on the loaded area shall not exceed the permissible bearing stress in direct compression multiplied by a value equal to

$$\sqrt{\frac{A_1}{A_2}} \text{ but not greater than } 2;$$

where

A_1 = supporting area for bearing of footing, which in sloped or stepped footing may be taken as the area of the lower base of the largest frustum of a pyramid or cone contained wholly within the footing and having for its upper base, the area actually loaded and having side slope of one vertical to two horizontal; and

A_2 = loaded area at the column base.

For working stress method of design the permissible bearing stress on full area of concrete shall be taken as $0.25 f_{ck}$; for limit state method of design the permissible bearing stress shall be $0.45 f_{ck}$.

34.4.1 Where the permissible bearing stress on the concrete in the supporting or supported member would be exceeded, reinforcement shall be provided for developing the excess force, either by extending the longitudinal bars into the supporting member, or by dowels (*see* 34.4.3).

34.4.2 Where transfer of force is accomplished by reinforcement, the development length of the reinforcement shall be sufficient to transfer the compression or tension to the supporting member in accordance with 26.2.

34.4.3 Extended longitudinal reinforcement or dowels of at least 0.5 percent of the cross-sectional area of the supported column or pedestal and a minimum of four bars shall be provided. Where dowels are used, their

diameter shall not exceed the diameter of the column bars by more than 3 mm.

34.4.4 Column bars of diameters larger than 36 mm, in compression only can be dowelled at the footings with bars of smaller size of the necessary area. The dowel shall extend into the column, a distance equal to the development length of the column bar and into the footing, a distance equal to the development length of the dowel.

34.5 Nominal Reinforcement

34.5.1 Minimum reinforcement and spacing shall be as per the requirements of solid slab.

34.5.2 The nominal reinforcement for concrete sections of thickness greater than 1 m shall be 360 mm^2 per metre length in each direction on each face. This provision does not supersede the requirement of minimum tensile reinforcement based on the depth of the section.

SECTION 5 STRUCTURAL DESIGN (LIMIT STATE METHOD)

35 SAFETY AND SERVICEABILITY REQUIREMENTS**35.1 General**

In the method of design based on limit state concept, the structure shall be designed to withstand safely all loads liable to act on it throughout its life; it shall also satisfy the serviceability requirements, such as limitations on deflection and cracking. The acceptable limit for the safety and serviceability requirements before failure occurs is called a 'limit state'. The aim of design is to achieve acceptable probabilities that the structure will not become unfit for the use for which it is intended, that is, that it will not reach a limit state.

35.1.1 All relevant limit states shall be considered in design to ensure an adequate degree of safety and serviceability. In general, the structure shall be designed on the basis of the most critical limit state and shall be checked for other limit states.

35.1.2 For ensuring the above objective, the design should be based on characteristic values for material strengths and applied loads, which take into account the variations in the material strengths and in the loads to be supported. The characteristic values should be based on statistical data if available; where such data are not available they should be based on experience. The 'design values' are derived from the characteristic values through the use of partial safety factors, one for material strengths and the other for loads. In the absence of special considerations these factors should have the values given in 36 according to the material, the type of loading and the limit state being considered.

35.2 Limit State of Collapse

The limit state of collapse of the structure or part of the structure could be assessed from rupture of one or more critical sections and from buckling due to elastic or plastic instability (including the effects of sway where appropriate) or overturning. The resistance to bending, shear, torsion and axial loads at every section shall not be less than the appropriate value at that section produced by the probable most unfavourable combination of loads on the structure using the appropriate partial safety factors.

35.3 Limit States of Serviceability**35.3.1 Deflection**

Limiting values of deflections are given in 23.2.

35.3.2 Cracking

Cracking of concrete should not adversely affect the appearance or durability of the structure; the acceptable

limits of cracking would vary with the type of structure and environment. Where specific attention is required to limit the designed crack width to a particular value, crack width calculation may be done using formula given in Annex F.

The practical objective of calculating crack width is merely to give guidance to the designer in making appropriate structural arrangements and in avoiding gross errors in design, which might result in concentration and excessive width of flexural crack.

The surface width of the cracks should not, in general, exceed 0.3 mm in members where cracking is not harmful and does not have any serious adverse effects upon the preservation of reinforcing steel nor upon the durability of the structures. In members where cracking in the tensile zone is harmful either because they are exposed to the effects of the weather or continuously exposed to moisture or in contact soil or ground water, an upper limit of 0.2 mm is suggested for the maximum width of cracks. For particularly aggressive environment, such as the 'severe' category in Table 3, the assessed surface width of cracks should not in general, exceed 0.1 mm.

35.4 Other Limit States

Structures designed for unusual or special functions shall comply with any relevant additional limit state considered appropriate to that structure.

36 CHARACTERISTIC AND DESIGN VALUES AND PARTIAL SAFETY FACTORS**36.1 Characteristic Strength of Materials**

The term 'characteristic strength' means that value of the strength of the material below which not more than 5 percent of the test results are expected to fall. The characteristic strength for concrete shall be in accordance with Table 2. Until the relevant Indian Standard Specifications for reinforcing steel are modified to include the concept of characteristic strength, the characteristic value shall be assumed as the minimum yield stress/0.2 percent proof stress specified in the relevant Indian Standard Specifications.

36.2 Characteristic Loads

The term 'characteristic load' means that value of load which has a 95 percent probability of not being exceeded during the life of the structure. Since data are not available to express loads in statistical terms, for the purpose of this standard, dead loads given in IS 875 (Part 1), imposed loads given in IS 875 (Part 2), wind loads given in IS 875 (Part 3), snow load as given in IS 875 (Part 4) and seismic forces given in IS 1893 shall be assumed as the characteristic loads.

36.3 Design Values

36.3.1 Materials

The design strength of the materials, f_d is given by

$$f_d = \frac{f}{\gamma_m}$$

where

f = characteristic strength of the material (see 36.1), and

γ_m = partial safety factor appropriate to the material and the limit state being considered.

36.3.2 Loads

The design load, F_d is given by

$$F_d = F\gamma_f$$

where

F = characteristic load (see 36.2), and

γ_f = partial safety factor appropriate to the nature of loading and the limit state being considered.

36.3.3 Consequences of Attaining Limit State

Where the consequences of a structure attaining a limit state are of a serious nature such as huge loss of life and disruption of the economy, higher values for γ_f and γ_m than those given under 36.4.1 and 36.4.2 may be applied.

36.4 Partial Safety Factors

36.4.1 Partial Safety Factor γ_f for Loads

The values of γ_f given in Table 18 shall normally be used.

36.4.2 Partial Safety Factor γ_m for Material Strength

36.4.2.1 When assessing the strength of a structure or structural member for the limit state of collapse, the values of partial safety factor, γ_m should be taken as 1.5 for concrete and 1.15 for steel.

NOTE — γ_m values are already incorporated in the equations and tables given in this standard for limit state design.

36.4.2.2 When assessing the deflection, the material properties such as modulus of elasticity should be taken as those associated with the characteristic strength of the material.

37 ANALYSIS

37.1 Analysis of Structure

Methods of analysis as in 22 shall be used. The material strength to be assumed shall be characteristic values in the determination of elastic properties of members irrespective of the limit state being considered. Redistribution of the calculated moments may be made as given in 37.1.1.

37.1.1. Redistribution of Moments in Continuous Beams and Frames

The redistribution of moments may be carried out satisfying the following conditions:

- Equilibrium between the internal forces and the external loads is maintained.
- The ultimate moment of resistance provided at any section of a member is not less than 70 percent of the moment at that section obtained from an elastic maximum moment diagram covering all appropriate combinations of loads.
- The elastic moment at any section in a member due to a particular combination of loads shall

Table 18 Values of Partial Safety Factor γ_f for Loads

(Clauses 18.2.3.1, 36.4.1 and B-4.3)

Load Combination	Limit State of Collapse			Limit States of Serviceability		
	DL (2)	IL (3)	WL (4)	DL (5)	IL (6)	WL (7)
(1)						
DL + IL	1.5		1.0	1.0	1.0	—
DL + WL	1.5 or 0.9 ^b	—	1.5	1.0	—	1.0
DL + IL + WL	1.2			1.0	0.8	0.8

NOTES

- While considering earthquake effects, substitute *EL* for *WL*.
- For the limit states of serviceability, the values of γ_f given in this table are applicable for short term effects. While assessing the long term effects due to creep the dead load and that part of the live load likely to be permanent may only be considered.

^b This value is to be considered when stability against overturning or stress reversal is critical.

not be reduced by more than 30 percent of the numerically largest moment given anywhere by the elastic maximum moments diagram for the particular member, covering all appropriate combination of loads.

- d) At sections where the moment capacity after redistribution is less than that from the elastic maximum moment diagram, the following relationship shall be satisfied:

$$\frac{x_u}{d} + \frac{\delta M}{100} \leq 0.6$$

where

x_u = depth of neutral axis,

d = effective depth, and

δM = percentage reduction in moment.

- e) In structures in which the structural frame provides the lateral stability, the reductions in moment allowed by condition 37.1.1 (c) shall be restricted to 10 percent for structures over 4 storeys in height.

37.1.2 Analysis of Slabs Spanning in Two Directions at Right Angles

Yield line theory or any other acceptable method may be used. Alternatively the provisions given in Annex D may be followed.

38 LIMIT STATE OF COLLAPSE : FLEXURE

38.1 Assumptions

Design for the limit state of collapse in flexure shall be based on the assumptions given below:

- a) Plane sections normal to the axis remain plane after bending.

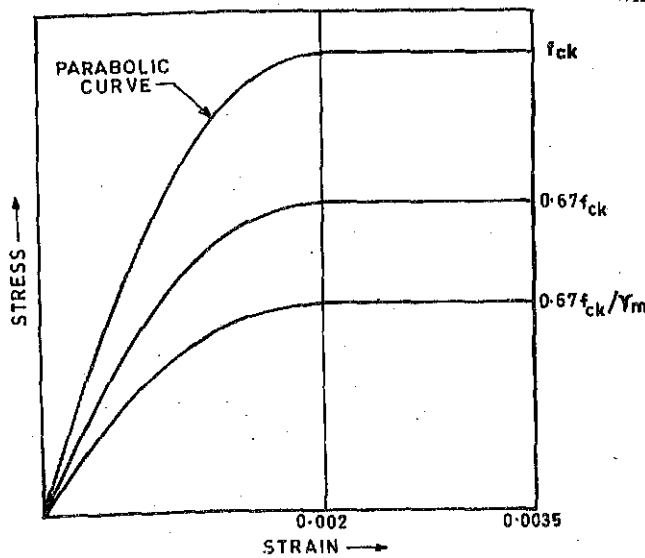

FIG. 21 STRESS-STRAIN CURVE FOR CONCRETE

- b) The maximum strain in concrete at the outermost compression fibre is taken as 0.0035 in bending.
- c) The relationship between the compressive stress distribution in concrete and the strain in concrete may be assumed to be rectangle, trapezoid, parabola or any other shape which results in prediction of strength in substantial agreement with the results of test. An acceptable stress-strain curve is given in Fig. 21. For design purposes, the compressive strength of concrete in the structure shall be assumed to be 0.67 times the characteristic strength. The partial safety factor $\gamma_m = 1.5$ shall be applied in addition to this.

NOTE — For the stress-strain curve in Fig. 21 the design stress block parameters are as follows (see Fig. 22):

Area of stress block = $0.36 f_{ck} x_u$

Depth of centre of compressive force from the extreme fibre in compression = $0.42 x_u$

where

f_{ck} = characteristic compressive strength of concrete, and

x_u = depth of neutral axis.

- d) The tensile strength of the concrete is ignored.
- e) The stresses in the reinforcement are derived from representative stress-strain curve for the type of steel used. Typical curves are given in Fig. 23. For design purposes the partial safety factor γ_m , equal to 1.15 shall be applied.
- f) The maximum strain in the tension reinforcement in the section at failure shall not be less than:

$$\frac{f_y}{1.15 E_s} + 0.002$$

where

f_y = characteristic strength of steel, and

E_s = modulus of elasticity of steel.

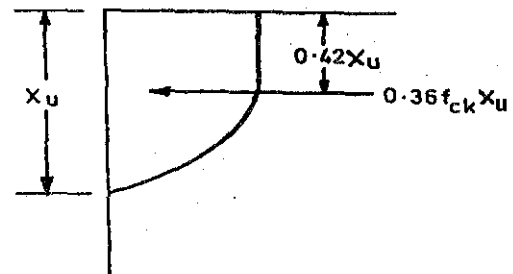
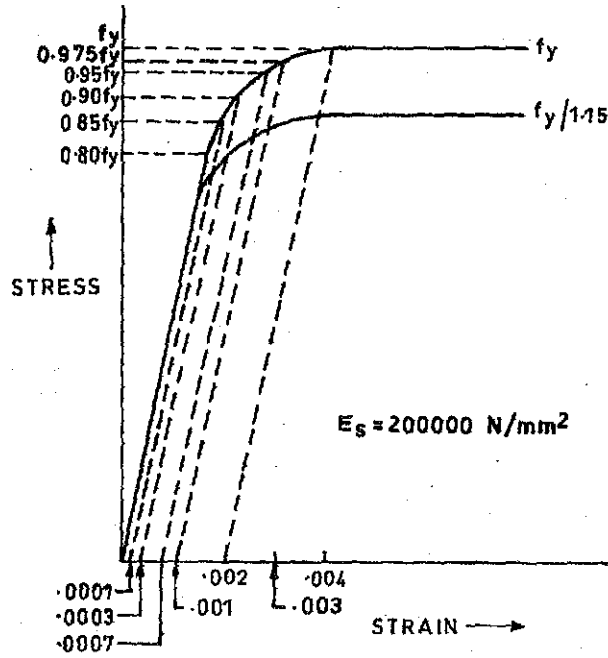
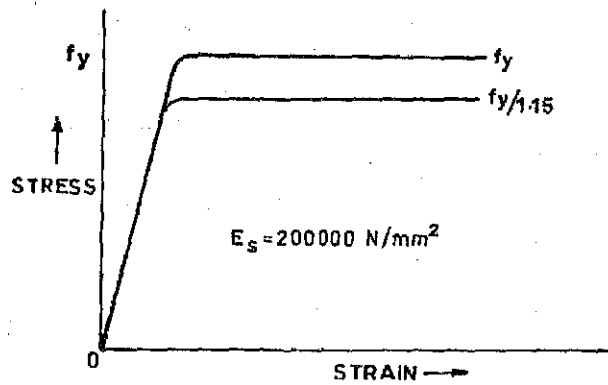

FIG. 22 STRESS BLOCK PARAMETERS



23A Cold Worked Deformed Bar



23B STEEL BAR WITH DEFINITE YIELD POINT

FIG. 23 REPRESENTATIVE STRESS-STRAIN CURVES FOR REINFORCEMENT

NOTE — The limiting values of the depth of neutral axis for different grades of steel based on the assumptions in 38.1 are as follows:

f_y	$x_{u, max}/d$
250	0.53
415	0.48
500	0.46

The expression for obtaining the moments of resistance for rectangular and T-Sections, based on the assumptions of 38.1, are given in Annex G.

**39 LIMIT STATE OF COLLAPSE :
COMPRESSION**

39.1 Assumptions

In addition to the assumptions given in 38.1 (a) to

38.1 (e) for flexure, the following shall be assumed:

- a) The maximum compressive strain in concrete in axial compression is taken as 0.002.
- b) The maximum compressive strain at the highly compressed extreme fibre in concrete subjected to axial compression and bending and when there is no tension on the section shall be 0.0035 minus 0.75 times the strain at the least compressed extreme fibre.

39.2 Minimum Eccentricity

All members in compression shall be designed for the minimum eccentricity in accordance with 25.4. Where

calculated eccentricity is larger, the minimum eccentricity should be ignored.

39.3 Short Axially Loaded Members in Compression

The member shall be designed by considering the assumptions given in 39.1 and the minimum eccentricity. When the minimum eccentricity as per 25.4 does not exceed 0.05 times the lateral dimension, the members may be designed by the following equation:

$$P_u = 0.4 f_{ck} A_c + 0.67 f_y A_{sc}$$

where

- P_u = axial load on the member,
- f_{ck} = characteristic compressive strength of the concrete,
- A_c = Area of concrete,
- f_y = characteristic strength of the compression reinforcement, and
- A_{sc} = area of longitudinal reinforcement for columns.

39.4 Compression Members with Helical Reinforcement

The strength of compression members with helical reinforcement satisfying the requirement of 39.4.1 shall be taken as 1.05 times the strength of similar member with lateral ties.

39.4.1 The ratio of the volume of helical reinforcement to the volume of the core shall not be less than $0.36 (A_g/A_c - 1) f_{ck}/f_y$

where

- A_g = gross area of the section,
- A_c = area of the core of the helically reinforced column measured to the outside diameter of the helix,
- f_{ck} = characteristic compressive strength of the concrete, and
- f_y = characteristic strength of the helical reinforcement but not exceeding 415 N/mm².

39.5 Members Subjected to Combined Axial Load and Uniaxial Bending

A member subjected to axial force and uniaxial bending shall be designed on the basis of 39.1 and 39.2.

NOTE—The design of member subject to combined axial load and uniaxial bending will involve lengthy calculation by trial and error. In order to overcome these difficulties interaction diagrams may be used. These have been prepared and published by BIS in 'SP : 16 Design aids for reinforced concrete to IS 456'.

39.6 Members Subjected to Combined Axial Load and Biaxial Bending

The resistance of a member subjected to axial force and biaxial bending shall be obtained on the basis of assumptions given in 39.1 and 39.2 with neutral axis so chosen as to satisfy the equilibrium of load and moments about two axes. Alternatively such members may be designed by the following equation:

$$\left[\frac{M_{ux}}{M_{uxl}} \right]^{\alpha_n} + \left[\frac{M_{uy}}{M_{uy1}} \right]^{\alpha_n} \leq 1.0$$

where

- M_{ux}, M_{uy} = moments about x and y axes due to design loads,
- M_{ux1}, M_{uy1} = maximum uniaxial moment capacity for an axial load of P_u , bending about x and y axes respectively, and

α_n is related to P_u/P_{uz}

where $P_{uz} = 0.45 f_{ck} A_c + 0.75 f_y A_{sc}$

For values of $P_u/P_{uz} = 0.2$ to 0.8 , the values of α_n vary linearly from 1.0 to 2.0 . For values less than 0.2 , α_n is 1.0 ; for values greater than 0.8 , α_n is 2.0 .

39.7 Slender Compression Members

The design of slender compression members (see 25.1.1) shall be based on the forces and the moments determined from an analysis of the structure, including the effect of deflections on moments and forces. When the effect of deflections are not taken into account in the analysis, additional moment given in 39.7.1 shall be taken into account in the appropriate direction.

39.7.1 The additional moments M_{ax} and M_{ay} shall be calculated by the following formulae:

$$M_{ax} = \frac{P_u D}{2000} \left\{ \frac{l_{ex}}{D} \right\}^2$$

$$M_{ay} = \frac{P_u b}{2000} \left\{ \frac{l_{ey}}{b} \right\}^2$$

where

- P_u = axial load on the member,
- l_{ex} = effective length in respect of the major axis,
- l_{ey} = effective length in respect of the minor axis,
- D = depth of the cross-section at right angles to the major axis, and
- b = width of the member.

For design of section, 39.5 or 39.6 as appropriate shall apply.

NOTES

- 1 A column may be considered braced in a given plane if lateral stability to the structure as a whole is provided by walls or bracing or buttressing designed to resist all lateral forces in that plane. It should otherwise be considered as unbraced.
- 2 In the case of a braced column without any transverse loads occurring in its height, the additional moment shall be added to an initial moment equal to sum of $0.4 M_{u1}$ and $0.6 M_{u2}$ where M_{u2} is the larger end moment and M_{u1} is the smaller end moment (assumed negative if the column is bent in double curvature). In no case shall the initial moment be less than $0.4 M_{u2}$ nor the total moment including the initial moment be less than M_{u2} . For unbraced columns, the additional moment shall be added to the end moments.
- 3 Unbraced compression members, at any given level or storey, subject to lateral load are usually constrained to deflect equally. In such cases slenderness ratio for each column may be taken as the average for all columns acting in the same direction.

39.7.1.1 The values given by equation 39.7.1 may be multiplied by the following factor:

$$k = \frac{P_{uz} - P_u}{P_{uz} - P_b} \leq 1$$

where

- P_u = axial load on compression member,
 P_{uz} = as defined in 39.6, and
 P_b = axial load corresponding to the condition of maximum compressive strain of 0.003 5 in concrete and tensile strain of 0.002 in outer most layer of tension steel.

40 LIMIT STATE OF COLLAPSE : SHEAR

40.1 Nominal Shear Stress

The nominal shear stress in beams of uniform depth shall be obtained by the following equation:

$$\tau_v = \frac{V_u}{b_d}$$

where

- V_u = shear force due to design loads;
 b = breadth of the member, which for flanged section shall be taken as the breadth of the web, b_w ; and
 d = effective depth.

40.1.1 Beams of Varying Depth

In the case of beams of varying depth the equation shall be modified as:

$$\tau_v = \frac{V_u \pm \frac{M_u}{d} \tan \beta}{bd}$$

where

- τ_v , V_u , b and d are the same as in 40.1,
 M_u = bending moment at the section, and
 β = angle between the top and the bottom edges

of the beam.

The negative sign in the formula applies when the bending moment M_u increases numerically in the same direction as the effective depth d increases, and the positive sign when the moment decreases numerically in this direction.

40.2 Design Shear Strength of Concrete

40.2.1 The design shear strength of concrete in beams without shear reinforcement is given in Table 19.

40.2.1.1 For solid slabs, the design shear strength for concrete shall be $\tau_c k$, where k has the values given below:

Overall Depth of Slab, mm	300 or more	275	250	225	200	175	150 or less
k	1.00	1.05	1.10	1.15	1.20	1.25	1.30

NOTE — This provision shall not apply to flat slabs for which 31.6 shall apply.

40.2.2 Shear Strength of Members under Axial Compression

For members subjected to axial compression P_u , the design shear strength of concrete, given in Table 19, shall be multiplied by the following factor :

$$\delta = 1 + \frac{3P_u}{A_g f_{ck}} \text{ but not exceeding } 1.5$$

where

- P_u = axial compressive force in Newtons,
 A_g = gross area of the concrete section in mm^2 ,
 and
 f_{ck} = characteristic compressive strength of concrete.

40.2.3 With Shear Reinforcement

Under no circumstances, even with shear reinforcement, shall the nominal shear stress in beams τ_v exceed τ_{cmax} given in Table 20.

40.2.3.1 For solid slabs, the nominal shear stress shall not exceed half the appropriate values given in Table 20.

40.3 Minimum Shear Reinforcement

When τ_v is less than τ_c given in Table 19, minimum shear reinforcement shall be provided in accordance with 26.5.1.6.

40.4 Design of Shear Reinforcement

When τ_v exceeds τ_c given in Table 19, shear reinforcement shall be provided in any of the following forms:

- a) Vertical stirrups,
- b) Bent-up bars along with stirrups, and

Table 19 Design Shear Strength of Concrete, τ_c , N/mm²
(Clauses 40.2.1, 40.2.2, 40.3, 40.4, 40.5.3, 41.3.2, 41.3.3 and 41.4.3)

$100 \frac{A_s}{bd}$	Concrete Grade					
	M 15	M 20	M 25	M 30	M 35	M 40 and above
(1)	(2)	(3)	(4)	(5)	(6)	(7)
≤ 0.15	0.28	0.28	0.29	0.29	0.29	0.30
0.25	0.35	0.36	0.36	0.37	0.37	0.38
0.50	0.46	0.48	0.49	0.50	0.50	0.51
0.75	0.54	0.56	0.57	0.59	0.59	0.60
1.00	0.60	0.62	0.64	0.66	0.67	0.68
1.25	0.64	0.67	0.70	0.71	0.73	0.74
1.50	0.68	0.72	0.74	0.76	0.78	0.79
1.75	0.71	0.75	0.78	0.80	0.82	0.84
2.00	0.71	0.79	0.82	0.84	0.86	0.88
2.25	0.71	0.81	0.85	0.88	0.90	0.92
2.50	0.71	0.82	0.88	0.91	0.93	0.95
2.75	0.71	0.82	0.90	0.94	0.96	0.98
3.00 and above	0.71	0.82	0.92	0.96	0.99	1.01

NOTE — The term A_s is the area of longitudinal tension reinforcement which continues at least one effective depth beyond the section being considered except at support where the full area of tension reinforcement may be used provided the detailing conforms to 26.2.2 and 26.2.3

Table 20 Maximum Shear Stress, $\tau_{c \max}$, N/mm²
(Clauses 40.2.3, 40.2.3.1, 40.5.1 and 41.3.1)

Concrete Grade	M 15	M 20	M 25	M 30	M 35	M 40 and above
$\tau_{c \max}$, N/mm ²	2.5	2.8	3.1	3.5	3.7	4.0

c) Inclined stirrups.

Where bent-up bars are provided, their contribution towards shear resistance shall not be more than half that of the total shear reinforcement.

Shear reinforcement shall be provided to carry a shear equal to $V_u - \tau_c bd$. The strength of shear reinforcement V_{us} shall be calculated as below:

a) For vertical stirrups:

$$V_{us} = \frac{0.87 f_y A_{sv} d}{s_v}$$

b) For inclined stirrups or a series of bars bent-up at different cross-sections:

$$V_{us} = \frac{0.87 f_y A_{sv} d}{s_v} (\sin \alpha + \cos \alpha)$$

c) For single bar or single group of parallel bars, all bent-up at the same cross-section:

$$V_{us} = 0.87 f_y A_{sv} \sin \alpha$$

where

A_{sv} = total cross-sectional area of stirrup legs or bent-up bars within a distance s_v .

s_v = spacing of the stirrups or bent-up bars along the length of the member,

τ_v = nominal shear stress,

τ_c = design shear strength of the concrete,

b = breadth of the member which for flanged beams, shall be taken as the breadth of the web b_w ,

f_y = characteristic strength of the stirrup or bent-up reinforcement which shall not be taken greater than 415 N/mm²,

α = angle between the inclined stirrup or bent-up bar and the axis of the member, not less than 45°, and

d = effective depth.

NOTES

- 1 Where more than one type of shear reinforcement is used to reinforce the same portion of the beam, the total shear resistance shall be computed as the sum of the resistance for the various types separately.
- 2 The area of the stirrups shall not be less than the minimum specified in 26.5.1.6.

40.5 Enhanced Shear Strength of Sections Close to Supports

40.5.1 General

Shear failure at sections of beams and cantilevers without shear reinforcement will normally occur on plane inclined at an angle 30° to the horizontal. If the angle of failure plane is forced to be inclined more steeply than this [because the section considered ($X-X$) in Fig. 24 is close to a support or for other reasons], the shear force required to produce failure is increased.

The enhancement of shear strength may be taken into account in the design of sections near a support by increasing design shear strength of concrete to $2d \tau_c / a_v$ provided that design shear stress at the face of the support remains less than the values given in Table 20. Account may be taken of the enhancement in any situation where the section considered is closer to the face of a support or concentrated load than twice the effective depth, d . To be effective, tension reinforcement should extend on each side of the point where it is intersected by a possible failure plane for a distance at least equal to the effective depth, or be provided with an equivalent anchorage.

40.5.2 Shear Reinforcement for Sections Close to Supports

If shear reinforcement is required, the total area of this

is given by:

$$A_s = a_v b (\tau_v - 2d \tau_c / a_v) / 0.87 f_y \geq 0.4 a_v b / 0.87 f_y$$

This reinforcement should be provided within the middle three quarters of a_v , where a_v is less than d , horizontal shear reinforcement will be effective than vertical.

40.5.3 Enhanced Shear Strength Near Supports (Simplified Approach)

The procedure given in 40.5.1 and 40.5.2 may be used for all beams. However for beams carrying generally uniform load or where the principal load is located farther than $2d$ from the face of support, the shear stress may be calculated at a section a distance d from the face of support. The value of τ_c is calculated in accordance with Table 19 and appropriate shear reinforcement is provided at sections closer to the support, no further check for shear at such sections is required.

41 LIMIT STATE OF COLLAPSE : TORSION

41.1 General

In structures, where torsion is required to maintain equilibrium, members shall be designed for torsion in accordance with 41.2, 41.3 and 41.4. However, for such indeterminate structures where torsion can be eliminated by releasing redundant restraints, no specific design for torsion is necessary, provided torsional stiffness is neglected in the calculation of internal forces. Adequate control of any torsional cracking is provided by the shear reinforcement as per 40.

NOTE — The approach to design in this clause is as follows: Torsional reinforcement is not calculated separately from that required for bending and shear. Instead the total longitudinal reinforcement is determined for a fictitious bending moment which is a function of actual bending moment and torsion;

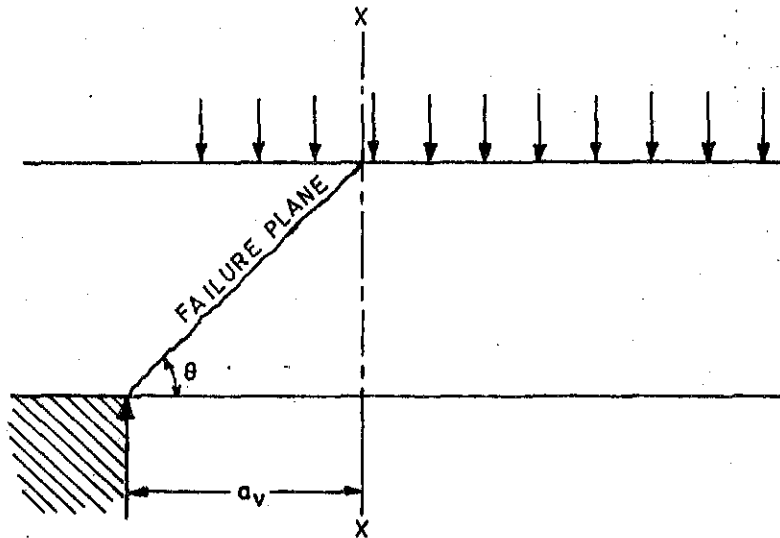

NOTE — The shear causing failure is that acting on section X-X.

FIG. 24 SHEAR FAILURE NEAR SUPPORTS

similarly web reinforcement is determined for a fictitious shear which is a function of actual shear and torsion.

41.1.1 The design rules laid down in **41.3** and **41.4** shall apply to beams of solid rectangular cross-section. However, these clauses may also be applied to flanged beams, by substituting b_w for b in which case they are generally conservative; therefore specialist literature may be referred to.

41.2 Critical Section

Sections located less than a distance d , from the face of the support may be designed for the same torsion as computed at a distance d , where d is the effective depth.

41.3 Shear and Torsion

41.3.1 Equivalent Shear

Equivalent shear, V_e , shall be calculated from the formula:

$$V_e = V_u + 1.6 \frac{T_u}{b}$$

where

- V_e = equivalent shear,
- V_u = shear,
- T_u = torsional moment, and
- b = breadth of beam.

The equivalent nominal shear stress, τ_{ve} in this case shall be calculated as given in **40.1**, except for substituting V_u by V_e . The values of τ_{ve} shall not exceed the values of $\tau_{c\max}$ given in Table 20.

41.3.2 If the equivalent nominal shear stress, τ_{ve} does not exceed τ_c given in Table 19, minimum shear reinforcement shall be provided as per **26.5.1.6**.

41.3.3 If τ_{ve} exceeds τ_c given in Table 19, both longitudinal and transverse reinforcement shall be provided in accordance with **41.4**.

41.4 Reinforcement in Members Subjected to Torsion

41.4.1 Reinforcement for torsion, when required, shall consist of longitudinal and transverse reinforcement.

41.4.2 Longitudinal Reinforcement

The longitudinal reinforcement shall be designed to resist an equivalent bending moment, M_{e1} , given by

$$M_{e1} = M_u + M_t$$

where

- M_u = bending moment at the cross-section, and
- $M_t = T_u \left(\frac{1+D/b}{1.7} \right)$

where

T_u is the torsional moment, D is the overall depth of the beam and b is the breadth of the beam.

41.4.2.1 If the numerical value of M_t as defined in **41.4.2** exceeds the numerical value of the moment M_u , longitudinal reinforcement shall be provided on the flexural compression face, such that the beam can also withstand an equivalent M_{e2} given by $M_{e2} = M_t - M_u$, the moment M_{e2} being taken as acting in the opposite sense to the moment M_u .

41.4.3 Transverse Reinforcement

Two legged closed hoops enclosing the corner longitudinal bars shall have an area of cross-section A_{sv} , given by

$$A_{sv} = \frac{T_u s_v}{b_1 d_1 (0.87 f_y)} + \frac{V_u s_v}{2.5 d_1 (0.87 f_y)}$$

but the total transverse reinforcement shall not be less than

$$\frac{(\tau_{ve} - \tau_c) b s_v}{0.87 f_y}$$

where

- T_u = torsional moment,
- V_u = shear force,
- s_v = spacing of the stirrup reinforcement,
- b_1 = centre-to-centre distance between corner bars in the direction of the width,
- d_1 = centre-to-centre distance between corner bars,
- b = breadth of the member,
- f_y = characteristic strength of the stirrup reinforcement,
- τ_{ve} = equivalent shear stress as specified in **41.3.1**, and
- τ_c = shear strength of the concrete as per Table 19.

42 LIMIT STATE OF SERVICEABILITY: DEFLECTION

42.1 Flexural Members

In all normal cases, the deflection of a flexural member will not be excessive if the ratio of its span to its effective depth is not greater than appropriate ratios given in **23.2.1**. When deflections are calculated according to Annex C, they shall not exceed the permissible values given in **23.2**.

**43 LIMIT STATE OF SERVICEABILITY:
CRACKING**

43.1 Flexural Members

In general, compliance with the spacing requirements of reinforcement given in 26.3.2 should be sufficient to control flexural cracking. If greater spacing are required, the expected crack width should be checked by formula given in Annex F.

43.2 Compression Members

Cracks due to bending in a compression member subjected to a design axial load greater than $0.2f_{ck}A_c$, where f_{ck} is the characteristic compressive strength of concrete and A_c is the area of the gross section of the member, need not be checked. A member subjected to lesser load than $0.2f_{ck}A_c$ may be considered as flexural member for the purpose of crack control (see 43.1).

Civil Junction

ANNEX A

(Clause 2)

LIST OF REFERRED INDIAN STANDARDS

IS No.	Title	IS No.	Title
269 : 1989	Specification for ordinary Portland cement, 33 grade (<i>fourth revision</i>)	1642 : 1989	Code of practice for fire safety of buildings (general) : Details of construction (<i>first revision</i>)
383 : 1970	Specification for coarse and fine aggregates from natural sources for concrete (<i>second revision</i>)	1786 : 1985	Specification for high strength deformed steel bars and wires for concrete reinforcement (<i>third revision</i>)
432 (Part 1) : 1982	Specification for mild steel and medium tensile steel bars and hard-drawn steel wire for concrete reinforcement: Part 1 Mild steel and medium tensile steel bars (<i>third revision</i>)	1791 : 1968	Specification for batch type concrete mixers (<i>second revision</i>)
455 : 1989	Specification for Portland slag cement (<i>fourth revision</i>)	1893 : 1984	Criteria for earthquake resistant design of structures (<i>fourth revision</i>)
516 : 1959	Method of test for strength of concrete	1904 : 1986	Code of practice for design and construction of foundations in soils : General requirements (<i>third revision</i>)
875	Code of practice for design loads (other than earthquake) for buildings and structures :	2062 : 1992	Steel for general structural purposes (<i>fourth revision</i>)
(Part 1) : 1987	Dead loads — Unit weights of building material and stored materials (<i>second revision</i>)	2386 (Part 3) : 1963	Methods of test for aggregates for concrete : Part 3 Specific gravity, density, voids, absorption and bulking
(Part 2) : 1987	Imposed loads (<i>second revision</i>)	2502 : 1963	Code of practice for bending and fixing of bars for concrete reinforcement
(Part 3) : 1987	Wind loads (<i>second revision</i>)	2505 : 1980	Concrete vibrators — Immersion type — General requirements
(Part 4) : 1987	Snow loads (<i>second revision</i>)	2506 : 1985	General requirements for screed board concrete vibrators (<i>first revision</i>)
(Part 5) : 1987	Special loads and load combinations (<i>second revision</i>)	2514 : 1963	Specification for concrete vibrating tables
1199 : 1959	Methods of sampling and analysis of concrete	2751 : 1979	Recommended practice for welding of mild steel plain and deformed bars for reinforced construction (<i>first revision</i>)
1343 : 1980	Code of practice for prestressed concrete (<i>first revision</i>)	3025	Methods of sampling and test (physical and chemical) for water and waste water :
1489	Specification for Portland pozzolana cement :	(Part 17) : 1984	Non-filterable residue (total suspended solids) (<i>first revision</i>)
(Part 1) : 1991	Fly ash based (<i>third revision</i>)	(Part 18) : 1984	Volatile and fixed residue (total filterable and non-filterable) (<i>first revision</i>)
(Part 2) : 1991	Calcined clay based (<i>third revision</i>)		
1566 : 1982	Specification for hard-drawn steel wire fabric for concrete reinforcement (<i>second revision</i>)		
1641 : 1988	Code of practice for fire safety of buildings (general): General principles of fire grading and classification (<i>first revision</i>)		

IS No.	Title	IS No.	Title
(Part 22) : 1986	Acidity (<i>first revision</i>)	(Part 3) : 1972	Concrete reinforcement
(Part 23) : 1986	Alkalinity (<i>first revision</i>)	(Part 4) : 1972	Types of concrete
(Part 24) : 1986	Sulphates (<i>first revision</i>)	(Part 5) : 1972	Formwork for concrete
(Part 32) : 1988	Chloride (<i>first revision</i>)	(Part 6) : 1972	Equipment, tool and plant
3414 : 1968	Code of practice for design and installation of joints in buildings	(Part 7) : 1973	Mixing, laying, compaction, curing and other construction aspect
3812 : 1981	Specification for fly ash for use as pozzolana and admixture (<i>first revision</i>)	(Part 8) : 1973	Properties of concrete
3951 (Part 1) : 1975	Specification for hollow clay tiles for floors and roofs : Part 1 Filler type (<i>first revision</i>)	(Part 9) : 1973	Structural aspects
4031 (Part 5) : 1988	Methods of physical tests for hydraulic cement : Part 5 Determination of initial and final setting times (<i>first revision</i>)	(Part 10) : 1973	Tests and testing apparatus
4082 : 1996	Recommendations on stacking and storage of construction materials and components at site (<i>second revision</i>)	(Part 11) : 1973	Prestressed concrete
4326 : 1993	Code of practice for earthquake resistant design and construction of buildings (<i>second revision</i>)	(Part 12) : 1973	Miscellaneous
4656 : 1968	Specification for form vibrators for concrete	6909 : 1990	Specification for supersulphated cement
4845 : 1968	Definitions and terminology relating to hydraulic cement	7861	Code of practice for extreme weather concreting :
4925 : 1968	Specification for concrete batching and mixing plant	(Part 1) : 1975	Recommended practice for hot weather concreting
4926 : 1976	Specification for ready-mixed concrete (<i>second revision</i>)	(Part 2) : 1975	Recommended practice for cold weather concreting
5816 : 1999	Method of test for splitting tensile strength of concrete (<i>first revision</i>)	8041 : 1990	Specification for rapid hardening Portland cement (<i>second revision</i>)
6061	Code of practice for construction of floor and roof with joists and filler blocks :	8043 : 1991	Specification for hydrophobic Portland cement (<i>second revision</i>)
(Part 1) : 1971	With hollow concrete filler blocks	8112 : 1989	Specification for 43 grade ordinary Portland cement (<i>first revision</i>)
(Part 2) : 1971	With hollow clay filler blocks (<i>first revision</i>)	9013 : 1978	Method of making, curing and determining compressive strength of accelerated cured concrete test specimens
6452 : 1989	Specification for high alumina cement for structural use	9103 : 1999	Specification for admixtures for concrete (<i>first revision</i>)
6461	Glossary of terms relating to cement:	9417 : 1989	Recommendations for welding cold worked bars for reinforced concrete construction (<i>first revision</i>)
(Part 1) : 1972	Concrete aggregates	11817 : 1986	Classification of joints in buildings for accommodation of dimensional deviations during construction
(Part 2) : 1972	Materials	12089 : 1987	Specification for granulated slag for manufacture of Portland slag cement
		12119 : 1987	General requirements for pan mixers for concrete

<i>IS No.</i>	<i>Title</i>	<i>IS No.</i>	<i>Title</i>
12269 : 1987	Specification for 53 grade ordinary Portland cement	(Part 1) : 1992 (Part 2) : 1992	Ultrasonic pulse velocity Rebound hammer
12330 : 1988	Specification for sulphate resisting Portland cement	13920 : 1993	Code of practice for ductile detailing of reinforced concrete structures subjected to seismic forces
12600 : 1989	Specification for low heat Portland cement		
13311	Methods of non-destructive testing of concrete :	14687 : 1999	Guidelines for falsework for concrete structures

ANNEX B

(Clauses 18.2.2, 22.3.1, 22.7, 26.2.1 and 32.1)

STRUCTURAL DESIGN (WORKING STRESS METHOD)

B-1 GENERAL

B-1.1 General Design Requirements

The general design requirements of Section 3 shall apply to this Annex.

B-1.2 Redistribution of Moments

Except where the simplified analysis using coefficients (see 22.5) is used, the moments over the supports for any assumed arrangement of loading, including the dead load moments may each be increased or decreased by not more than 15 percent, provided that these modified moments over the supports are used for the calculation of the corresponding moments in the spans.

B-1.3 Assumptions for Design of Members

In the methods based on elastic theory, the following assumptions shall be made:

- At any cross-section, plane sections before bending remain plain after bending.
- All tensile stresses are taken up by reinforcement and none by concrete, except as otherwise specifically permitted.

c) The stress-strain relationship of steel and concrete, under working loads, is a straight line.

d) The modular ratio m has the value $\frac{280}{3\sigma_{cbc}}$

where σ_{cbc} is permissible compressive stress due to bending in concrete in N/mm^2 as specified in Table 21.

NOTE — The expression given for m partially takes into account long-term effects such as creep. Therefore this m is not the same as the modular ratio derived based on the value of E_c given in 6.2.3.1.

B-2 PERMISSIBLE STRESSES

B-2.1 Permissible Stresses in Concrete

Permissible stresses for the various grades of concrete shall be taken as those given in Tables 21 and 23.

NOTE — For increase in strength with age 6.2.1 shall be applicable. The values of permissible stress shall be obtained by interpolation between the grades of concrete.

B-2.1.1 Direct Tension

For members in direct tension, when full tension is taken by the reinforcement alone, the tensile stress shall be not greater than the values given below:

Grade of Concrete	M 10	M 15	M 20	M 25	M 30	M 35	M 40	M 45	M 50
Tensile Stress, N/mm^2	1.2	2.0	2.8	3.2	3.6	4.0	4.4	4.8	5.2

The tensile stress shall be calculated as $\frac{F_t}{A_c + m A_{st}}$

where

F_t = total tension on the member minus pre-tension in steel, if any, before concreting;

A_c = cross-sectional area of concrete excluding any finishing material and reinforcing steel;

m = modular ratio; and

A_{st} = cross-sectional area of reinforcing steel in tension.

B-2.1.2 Bond Stress for Deformed Bars

In the case of deformed bars conforming to IS 1786, the bond stresses given in Table 21 may be increased by 60 percent.

B-2.2 Permissible Stresses in Steel Reinforcement

Permissible stresses in steel reinforcement shall not exceed the values specified in Table 22.

B-2.2.1 In flexural members the value of σ_{st} given in Table 22 is applicable at the centroid of the tensile reinforcement subject to the condition that when more than one layer of tensile reinforcement is provided, the stress at the centroid of the outermost layer shall not exceed by more than 10 percent the value given in Table 22.

B-2.3 Increase in Permissible Stresses

Where stresses due to wind (or earthquake) temperature and shrinkage effects are combined with those due to dead, live and impact load, the stresses specified in Tables 21, 22 and 23 may be exceeded upto a limit of

$33\frac{1}{3}$ percent. Wind and seismic forces need not be considered as acting simultaneously.

Table 21 Permissible Stresses in Concrete

IS 456 : 2000

(Clauses B-1.3, B-2.1, B-2.1.2, B-2.3 and B-4.2)

All values in N/mm².

Grade of Concrete	Permissible Stress in Compression		Permissible Stress in Bond (Average) for Plain Bars in Tension
	Bending	Direct	
(1)	(2)	(3)	(4)
	σ_{cbc}	σ_{cc}	τ_{bd}
M 10	3.0	2.5	—
M 15	5.0	4.0	0.6
M 20	7.0	5.0	0.8
M 25	8.5	6.0	0.9
M 30	10.0	8.0	1.0
M 35	11.5	9.0	1.1
M 40	13.0	10.0	1.2
M 45	14.5	11.0	1.3
M 50	16.0	12.0	1.4

NOTES

- 1 The values of permissible shear stress in concrete are given in Table 23.
- 2 The bond stress given in col 4 shall be increased by 25 percent for bars in compression.

B-3 PERMISSIBLE LOADS IN COMPRESSION MEMBERS

B-3.1 Pedestals and Short Columns with Lateral Ties

The axial load P permissible on a pedestal or short column reinforced with longitudinal bars and lateral ties shall not exceed that given by the following equation :

$$P = \sigma_{cc} A_c + \sigma_{sc} A_{sc}$$

where

- σ_{cc} = permissible stress in concrete in direct compression,
- A_c = cross-sectional area of concrete excluding any finishing material and reinforcing steel,
- σ_{sc} = permissible compressive stress for column bars, and
- A_{sc} = cross-sectional area of the longitudinal steel.

NOTE — The minimum eccentricity mentioned in 25.4 may be deemed to be incorporated in the above equation.

B-3.2 Short Columns with Helical Reinforcement

The permissible load for columns with helical reinforcement satisfying the requirement of 39.4.1 shall be 1.05 times the permissible load for similar member with lateral ties or rings.

B-3.3 Long Columns

The maximum permissible stress in a reinforced concrete column or part thereof having a ratio of effective column length to least lateral dimension above 12 shall not exceed that which results from the

multiplication of the appropriate maximum permissible stress as specified under B-2.1 and B-2.2 by the coefficient C_r given by the following formula:

$$C_r = 1.25 - \frac{l_{ef}}{48 b}$$

where

- C_r = reduction coefficient;
- l_{ef} = effective length of column; and
- b = least lateral dimension of column; for column with helical reinforcement, b is the diameter of the core.

For more exact calculations, the maximum permissible stresses in a reinforced concrete column or part thereof having a ratio of effective column length to least lateral radius of gyration above 40 shall not exceed those which result from the multiplication of the appropriate maximum permissible stresses specified under B-2.1 and B-2.2 by the coefficient C_r given by the following formula:

$$C_r = 1.25 - \frac{l_{ef}}{160 i_{min}}$$

where i_{min} is the least radius of gyration.

B-3.4 Composite Columns

- a) **Allowable load** — The allowable axial load P on a composite column consisting of structural steel or cast-iron column thoroughly encased in concrete reinforced with both longitudinal and spiral reinforcement, shall not exceed that given by the following formula:

$$P = \sigma_{cc} A_c + \sigma_{sc} A_{sc} + \sigma_{mc} A_m$$

Table 22 Permissible Stresses in Steel Reinforcement
(Clauses B-2.2, B-2.2.1, B-2.3 and B-4.2)

Sl No.	Type of Stress in Steel Reinforcement	Permissible Stresses in N/mm ²		
		Mild Steel Bars Conforming to Grade I of IS 432 (Part 1)	Medium Tensile Steel Conforming to IS 432 (Part 1)	High Yield Strength Deformed Bars Conforming to IS 1786 (Grade Fe 415)
(1)	(2)	(3)	(4)	(5)
i)	Tension (σ_{st} or σ_{sv})			
a)	Up to and including 20 mm	140	Half the guaranteed yield stress subject to a maximum of 190	230
b)	Over 20 mm	130		230
ii)	Compression in column bars (σ_{sc})	130	130	190
iii)	Compression in bars in a beam or slab when the compressive resistance of the concrete is taken into account	The calculated compressive stress in the surrounding concrete multiplied by 1.5 times the modular ratio or σ_{sc} whichever is lower		
iv)	Compression in bars in a beam or slab where the compressive resistance of the concrete is not taken into account:			
a)	Up to and including 20 mm	140	Half the guaranteed yield stress subject to a maximum of 190	190
b)	Over 20 mm	130		190

NOTES

- For high yield strength deformed bars of Grade Fe 500 the permissible stress in direct tension and flexural tension shall be $0.55 f_y$. The permissible stresses for shear and compression reinforcement shall be as for Grade Fe 415.
- For welded wire fabric conforming to IS 1566, the permissible value in tension σ_{st} is 230 N/mm^2 .
- For the purpose of this standard, the yield stress of steels for which there is no clearly defined yield point should be taken to be 0.2 percent proof stress.
- When mild steel conforming to Grade II of IS 432 (Part 1) is used, the permissible stresses shall be 90 percent of the permissible stresses in col 3, or if the design details have already been worked out on the basis of mild steel conforming to Grade I of IS 432 (Part 1); the area of reinforcement shall be increased by 10 percent of that required for Grade I steel.

where

σ_{cc} = permissible stress in concrete in direct compression;

A_c = net area of concrete section; which is equal to the gross area of the concrete section $- A_{sc} - A_m$;

σ_{sc} = permissible compressive stress for column bars;

A_{sc} = cross-sectional area of longitudinal bar reinforcement;

σ_{mc} = allowable unit stress in metal core, not to exceed 125 N/mm^2 for a steel core, or 70 N/mm^2 for a cast iron core; and

A_m = the cross-sectional area of the steel or cast iron core.

- b) *Metal core and reinforcement* — The cross-sectional area of the metal core shall not exceed

20 percent of the gross area of the column. If a hollow metal core is used, it shall be filled with concrete. The amount of longitudinal and spiral reinforcement and the requirements as to spacing of bars, details of splices and thickness of protective shell outside the spiral, shall conform to requirements of 26.5.3. A clearance of at least 75 mm shall be maintained between the spiral and the metal core at all points, except that when the core consists of a structural steel H-column, the minimum clearance may be reduced to 50 mm.

- c) *Splices and connections of metal cores* — Metal cores in composite columns shall be accurately milled at splices and positive provisions shall be made for alignment of one core above another. At the column base, provisions shall be

made to transfer the load to the footing at safe unit stresses in accordance with 34. The base of the metal section shall be designed to transfer the load from the entire composite columns to the footing, or it may be designed to transfer the load from the metal section only, provided it is placed in the pier or pedestal as to leave ample section of concrete above the base for the transfer of load from the reinforced concrete section of the column by means of bond on the vertical reinforcement and by direct compression on the concrete. Transfer of loads to the metal core shall be provided for by the use of bearing members, such as billets, brackets or other positive connections, these shall be provided at the top of the metal core and at intermediate floor levels where required. The column as a whole shall satisfy the requirements of formula given under (a) at any point; in addition to this, the reinforced concrete portion shall be designed to carry, according to B-3.1 or B-3.2 as the case may be, all floor loads brought into the column at levels between the metal brackets or connections. In applying the formulae under B-3.1 or B-3.2 the gross area of column shall be taken to be the area of the concrete section outside the metal core, and the allowable load on the reinforced concrete section shall be further limited to $0.28 f_{ck}$ times gross sectional area of the column.

- d) *Allowable Load on Metal Core Only* — The metal core of composite columns shall be designed to carry safely any construction or other loads to be placed upon them prior to their encasement in concrete.

B-4 MEMBERS SUBJECTED TO COMBINED AXIAL LOAD AND BENDING

B-4.1 Design Based on Uncracked Section

A member subjected to axial load and bending (due to eccentricity of load, monolithic construction, lateral forces, etc) shall be considered safe provided the following conditions are satisfied:

$$a) \frac{\sigma_{cc, cal}}{\sigma_{cc}} + \frac{\sigma_{cbc, cal}}{\sigma_{cbc}} \leq 1$$

where

- $\sigma_{cc, cal}$ = calculated direct compressive stress in concrete,
 σ_{cc} = permissible axial compressive stress in concrete,
 $\sigma_{cbc, cal}$ = calculated bending compressive stress in concrete, and
 σ_{cbc} = permissible bending compressive stress in concrete.

- b) The resultant tension in concrete is not greater than 35 percent and 25 percent of the resultant compression for biaxial and uniaxial bending respectively, or does not exceed three-fourths, the 7 day modulus of rupture of concrete.

NOTES

1 $\sigma_{cc, cal} = \frac{P}{A_c + 1.5mA_{sc}}$ for columns with ties where P , A_c and A_{sc} defined in B-3.1 and m is the modular ratio.

2 $\sigma_{cbc, cal} = \frac{M}{Z}$ where M equals the moment and Z equals modulus of section. In the case of sections subject to moments in two directions, the stress shall be calculated separately and added algebraically.

B-4.2 Design Based on Cracked Section

If the requirements specified in B-4.1 are not satisfied, the stresses in concrete and steel shall be calculated by the theory of cracked section in which the tensile resistance of concrete is ignored. If the calculated stresses are within the permissible stress specified in Tables 21, 22 and 23 the section may be assumed to be safe.

NOTE — The maximum stress in concrete and steel may be found from tables and charts based on the cracked section theory or directly by determining the no-stress line which should satisfy the following requirements:

- The direct load should be equal to the algebraic sum of the forces on concrete and steel,
- The moment of the external loads about any reference line should be equal to the algebraic sum of the moment of the forces in concrete (ignoring the tensile force in concrete) and steel about the same line, and
- The moment of the external loads about any other reference lines should be equal to the algebraic sum of the moment of the forces in concrete (ignoring the tensile force in concrete) and steel about the same line.

B-4.3 Members Subjected to Combined Direct Load and Flexure

Members subjected to combined direct load and flexure and shall be designed by limit state method as in 39.5 after applying appropriate load factors as given in Table 18.

B-5 SHEAR

B-5.1 Nominal Shear Stress

The nominal shear stress τ_v in beams or slabs of uniform depth shall be calculated by the following equation:

$$\tau_v = \frac{V}{bd}$$

where

V = shear force due to design loads,

b = breadth of the member, which for flanged sections shall be taken as the breadth of the web, and

d = effective depth.

B-5.1.1 Beams of Varying Depth

In the case of beams of varying depth, the equation shall be modified as:

$$\tau_v = \frac{V \pm \frac{M \tan \beta}{d}}{bd}$$

where

τ_v , V , b and d are the same as in B-5.1,

M = bending moment at the section, and

β = angle between the top and the bottom edges of the beam.

The negative sign in the formula applies when the bending moment M increases numerically in the same direction as the effective depth d increases, and the positive sign when the moment decreases numerically in this direction.

B-5.2 Design Shear Strength of Concrete

B-5.2.1 The permissible shear stress in concrete in beams without shear reinforcement is given in Table 23.

B-5.2.1.1 For solid slabs the permissible shear stress in concrete shall be $k\tau_c$ where k has the value given below:

Overall depth of slab, mm	300 or more	275	250	225	200	175	150 or less
k	1.00	1.05	1.10	1.15	1.20	1.25	1.30

NOTE — This does not apply to flat slabs for which 31.6 shall apply.

B-5.2.2 Shear Strength of Members Under Axial Compression

For members subjected to axial compression P , the permissible shear stress in concrete τ_c given in Table 23, shall be multiplied by the following factor:

$$\delta = 1 + \frac{5P}{A_g f_{ck}}, \text{ but not exceeding } 1.5$$

where

P = axial compressive force in N,

A_g = gross area of the concrete section in mm², and

f_{ck} = characteristic compressive strength of concrete.

B-5.2.3 With Shear Reinforcement

When shear reinforcement is provided the nominal shear stress τ_c in beams shall not exceed $\tau_{c \max}$ given in Table 24.

Table 23 Permissible Shear Stress in Concrete

(Clauses B-2.1, B-2.3, B-4.2, B-5.2.1, B-5.2.2, B-5.3, B-5.4, B-5.5.1, B-5.5.3, B-6.3.2, B-6.3.3 and B-6.4.3 and Table 21)

100 $\frac{A_s}{bd}$	Permissible Shear Stress in Concrete, τ_c , N/mm ²					
	Grade of Concrete					
	M 15	M 20	M 25	M 30	M 35	M 40 and above
(1)	(2)	(3)	(4)	(5)	(6)	(7)
≤ 0.15	0.18	0.18	0.19	0.20	0.20	0.20
0.25	0.22	0.22	0.23	0.23	0.23	0.23
0.50	0.29	0.30	0.31	0.31	0.31	0.32
0.75	0.34	0.35	0.36	0.37	0.37	0.38
1.00	0.37	0.39	0.40	0.41	0.42	0.42
1.25	0.40	0.42	0.44	0.45	0.45	0.46
1.50	0.42	0.45	0.46	0.48	0.49	0.49
1.75	0.44	0.47	0.49	0.50	0.52	0.52
2.00	0.44	0.49	0.51	0.53	0.54	0.55
2.25	0.44	0.51	0.53	0.55	0.56	0.57
2.50	0.44	0.51	0.55	0.57	0.58	0.60
2.75	0.44	0.51	0.56	0.58	0.60	0.62
3.00 and above	0.44	0.51	0.57	0.60	0.62	0.63

NOTE — A_s is that area of longitudinal tension reinforcement which continues at least one effective depth beyond the section being considered except at supports where the full area of tension reinforcement may be used provided the detailing conforms to 26.2.2 and 26.2.3.

B-5.2.3.1 For slabs, τ_v shall not exceed half the value of $\tau_{c\max}$ given in Table 24.

B-5.3 Minimum Shear Reinforcement

When τ_v is less than τ_c given in Table 23, minimum shear reinforcement shall be provided in accordance with 26.5.1.6.

B-5.4 Design of Shear Reinforcement

When τ_v exceeds τ_c given in Table 23, shear reinforcement shall be provided in any of the following forms:

- Vertical stirrups,
- Bent-up bars along with stirrups, and
- Inclined stirrups.

Where bent-up bars are provided, their contribution towards shear resistance shall not be more than half that of the total shear reinforcement.

Shear reinforcement shall be provided to carry a shear equal to $V - \tau_c bd$. The strength of shear reinforcement V_s shall be calculated as below:

- For vertical stirrups

$$V_s = \frac{\sigma_{sv} A_{sv} d}{s_v}$$

- For inclined stirrups or a series of bars bent-up at different cross-sections:

$$V_s = \frac{\sigma_{sv} A_{sv} d}{s_v} (\sin \alpha + \cos \alpha)$$

- For single bar or single group of parallel bars, all bent-up at the same cross-section:

$$V_s = \sigma_{sv} A_{sv} \sin \alpha$$

where

- A_{sv} = total cross-sectional area of stirrup legs or bent-up bars within a distance,
- s_v = spacing of the stirrups or bent-up bars along the length of the member,
- τ_c = design shear strength of the concrete,
- b = breadth of the member which for flanged beams, shall be taken as the breadth of the web b_w ,
- σ_{sv} = permissible tensile stress in shear reinforcement which shall not be taken

greater than 230 N/mm²,

α = angle between the inclined stirrup or bent-up bar and the axis of the member, not less than 45°, and

d = effective depth.

NOTE — Where more than one type of shear reinforcement is used to reinforce the same portion of the beam, the total shear resistance shall be computed as the sum of the resistance for the various types separately. The area of the stirrups shall not be less than the minimum specified in 26.5.1.6.

B-5.5 Enhanced Shear Strength of Sections Close to Supports

B-5.5.1 General

Shear failure at sections of beams and cantilevers without shear reinforcement will normally occur on plane inclined at an angle 30° to the horizontal. If the angle of failure plane is forced to be inclined more steeply than this [because the section considered (X - X) in Fig. 24 is close to a support or for other reasons], the shear force required to produce failure is increased.

The enhancement of shear strength may be taken into account in the design of sections near a support by increasing design shear strength of concrete, τ_c to $2d \tau_c / a_v$ provided that the design shear stress at the face of support remains less than the values given in Table 23. Account may be taken of the enhancement in any situation where the section considered is closer to the face of a support of concentrated load than twice the effective depth, d . To be effective, tension reinforcement should extend on each side of the point where it is intersected by a possible failure plane for a distance at least equal to the effective depth, or be provided with an equivalent anchorage.

B-5.5.2 Shear Reinforcement for Sections Close to Supports

If shear reinforcement is required, the total area of this is given by:

$$A_s = a_v b (\tau_v - 2d \tau_c / a_v) / 0.87 f_y \geq 0.4 a_v b / 0.87 f_y$$

This reinforcement should be provided within the middle three quarters of a_v . Where a_v is less than d , horizontal shear reinforcement will be more effective than vertical.

Table 24 Maximum Shear Stress, $\tau_{c\max}$, N/mm²
(Clauses B-5.2.3, B-5.2.3.1, B-5.5.1 and B-6.3.1)

Concrete Grade	M 15	M 20	M 25	M 30	M 35	M 40 and above
$\tau_{c\max}$, N/mm ²	1.6	1.8	1.9	2.2	2.3	2.5

B-5.5.3 Enhanced Shear Strength Near Supports (Simplified Approach)

The procedure given in B-5.5.1 and B-5.5.2 may be used for all beams. However for beams carrying generally uniform load or where the principal load is located further than $2d$ from the face of support, the shear stress may be calculated at a section a distance d from the face of support. The value of τ_c is calculated in accordance with Table 23 and appropriate shear reinforcement is provided at sections closer to the support, no further check for such section is required.

B-6 TORSION**B-6.1 General**

In structures where torsion is required to maintain equilibrium, members shall be designed for torsion in accordance with B-6.2, B-6.3 and B-6.4. However, for such indeterminate structures where torsion can be eliminated by releasing redundant restraints, no specific design for torsion is necessary provided torsional stiffness is neglected in the calculation of internal forces. Adequate control of any torsional cracking is provided by the shear reinforcement as per B-5.

NOTE — The approach to design in this clause for torsion is as follows:

Torsional reinforcement is not calculated separately from that required for bending and shear. Instead the total longitudinal reinforcement is determined for a fictitious bending moment which is a function of actual bending moment and torsion; similarly web reinforcement is determined for a fictitious shear which is a function of actual shear and torsion.

B-6.1.1 The design rules laid down in B-6.3 and B-6.4 shall apply to beams of solid rectangular cross-section. However, these clauses may also be applied to flanged beams by substituting b_w for b , in which case they are generally conservative; therefore specialist literature may be referred to.

B-6.2 Critical Section

Sections located less than a distance d , from the face of the support may be designed for the same torsion as computed at a distance d , where d is the effective depth.

B-6.3 Shear and Torsion**B-6.3.1 Equivalent Shear**

Equivalent shear, V_e shall be calculated from the formula:

$$V_e = V + 1.6 \frac{T}{b}$$

where

$$V_e = \text{equivalent shear,}$$

V = shear,

T = torsional moment, and

b = breadth of beam.

The equivalent nominal shear stress, τ_{ve} , in this case shall be calculated as given in B-5.1, except for substituting V by V_e . The values of τ_{ve} shall not exceed the values of $\tau_{c_{max}}$ given in Table 24.

B-6.3.2 If the equivalent nominal shear stress τ_{ve} does not exceed τ_c given in Table 23, minimum shear reinforcement shall be provided as specified in 26.5.1.6.

B-6.3.3 If τ_{ve} exceeds τ_c given in Table 23, both longitudinal and transverse reinforcement shall be provided in accordance with B-6.4.

B-6.4 Reinforcement in Members Subjected to Torsion

B-6.4.1 Reinforcement for torsion, when required, shall consist of longitudinal and transverse reinforcement.

B-6.4.2 Longitudinal Reinforcement

The longitudinal reinforcement shall be designed to resist an equivalent bending moment, M_{e1} , given by

$$M_{e1} = M + M_t$$

where

M = bending moment at the cross-section, and

$M_t = T \frac{(1+D/b)}{1.7}$, where T is the torsional moment, D is the overall depth of the beam and b is the breadth of the beam.

B-6.4.2.1 If the numerical value of M_t as defined in B-6.4.2 exceeds the numerical value of the moment M , longitudinal reinforcement shall be provided on the flexural compression face, such that the beam can also withstand an equivalent moment M_{e2} given by $M_{e2} = M_t - M$, the moment M_{e2} being taken as acting in the opposite sense to the moment M .

B-6.4.3 Transverse Reinforcement

Two legged closed hoops enclosing the corner longitudinal bars shall have an area of cross-section A_{sv} , given by

$$A_{sv} = \frac{T.s_v}{b_1 d_1 \sigma_{sv}} + \frac{V.s_v}{2.5 d_1 \sigma_{sv}}$$

but the total transverse reinforcement shall not be less than

$$\frac{(\tau_{ve} - \tau_c) b.s_v}{\sigma_{sv}}$$

where

T = torsional moment,

V = shear force,

s_v = spacing of the stirrup reinforcement,
 b_1 = centre-to-centre distance between corner
bars in the direction of the width,
 d_1 = centre-to-centre distance between corner
bars in the direction of the depth,
 b = breadth of the member,

σ_{sv} = permissible tensile stress in shear
reinforcement,
 τ_{ve} = equivalent shear stress as specified in
B-6.3.1, and
 τ_c = shear strength of the concrete as specified
in Table 23.

ANNEX C

(Clauses 22.3.2, 23.2.1 and 42.1)

CALCULATION OF DEFLECTION

C-1 TOTAL DEFLECTION

C-1.1 The total deflection shall be taken as the sum of the short-term deflection determined in accordance with C-2 and the long-term deflection, in accordance with C-3 and C-4.

C-2 SHORT-TERM DEFLECTION

C-2.1 The short-term deflection may be calculated by the usual methods for elastic deflections using the short-term modulus of elasticity of concrete, E_c and an effective moment of inertia I_{eff} given by the following equation:

$$I_{eff} = \frac{I_r}{1.2 - \frac{M_r}{M} \frac{z}{d} \left(1 - \frac{x}{d}\right) \frac{b_w}{b}}; \text{ but}$$

$$I_r \leq I_{eff} \leq I_{gr}$$

where

I_r = moment of inertia of the cracked section,

M_r = cracking moment, equal to $\frac{f_{cr} I_{gr}}{y_t}$ where

f_{cr} is the modulus of rupture of concrete,
 I_{gr} is the moment of inertia of the gross section about the centroidal axis, neglecting the reinforcement, and y_t is the distance from centroidal axis of gross section, neglecting the reinforcement, to extreme fibre in tension,

M = maximum moment under service loads,

z = lever arm,

x = depth of neutral axis,

d = effective depth,

b_w = breadth of web, and

b = breadth of compression face.

For continuous beams, deflection shall be calculated using the values of I_r , I_{gr} and M_r modified by the following equation:

$$X_e = k_1 \left[\frac{X_1 + X_2}{2} \right] + (1 - k_1) X_0$$

where

X_e = modified value of X ,

X_1, X_2 = values of X at the supports,

X_0 = value of X at mid span,

k_1 = coefficient given in Table 25, and

X = value of I_r, I_{gr} or M_r as appropriate.

C-3 DEFLECTION DUE TO SHRINKAGE

C-3.1 The deflection due to shrinkage a_{cs} may be computed from the following equation:

$$a_{cs} = k_3 \Psi_{cs} l^2$$

where

k_3 is a constant depending upon the support conditions,

0.5 for cantilevers,

0.125 for simply supported members,

0.086 for members continuous at one end, and

0.063 for fully continuous members.

Ψ_{cs} is shrinkage curvature equal to $k_4 \frac{\epsilon_{cs}}{D}$

where ϵ_{cs} is the ultimate shrinkage strain of concrete (see 6.2.4),

$$k_4 = 0.72 \times \frac{P_t - P_c}{\sqrt{P_t}} \leq 1.0 \text{ for } 0.25 \leq P_t - P_c < 1.0$$

$$= 0.65 \times \frac{P_t - P_c}{\sqrt{P_t}} \leq 1.0 \text{ for } P_t - P_c \geq 1.0$$

Table 25 Values of Coefficient, k_1

(Clause C-2.1)

k_2	0.5 or less	0.6	0.7	0.8	0.9	1.0	1.1	1.2	1.3	1.4
k_1	0	0.03	0.08	0.16	0.30	0.50	0.73	0.91	0.97	1.0

NOTE — k_2 is given by

$$k_2 = \frac{M_1 + M_2}{M_{F1} + M_{F2}}$$

where

M_1, M_2 = support moments, and

M_{F1}, M_{F2} = fixed end moments.

where $P_t = \frac{100 A_{st}}{bd}$ and $P_c = \frac{100 A_{sc}}{bd}$

and D is the total depth of the section, and l is the length of span.

C-4 DEFLECTION DUE TO CREEP

C-4.1 The creep deflection due to permanent loads $a_{cc(perm)}$ may be obtained from the following equation:

$$a_{cc(perm)} = a_{i,cc(perm)} - a_{i(perm)}$$

where

$a_{i,cc(perm)}$ = initial plus creep deflection due to permanent loads obtained using an elastic analysis with an effective modulus of elasticity,

$E_{ce} = \frac{E_c}{1+\theta}$; θ being the creep coefficient, and

$a_{i(perm)}$ = short-term deflection due to permanent load using E_c .

ANNEX D

(Clauses 24.4 and 37.1.2)

SLABS SPANNING IN TWO DIRECTIONS

D-1 RESTRAINED SLABS

D-1.0 When the corners of a slab are prevented from lifting, the slab may be designed as specified in D-1.1 to D-1.11.

D-1.1 The maximum bending moments per unit width in a slab are given by the following equations:

$$M_x = \alpha_x w l_x^2$$

$$M_y = \alpha_y w l_y^2$$

where

α_x and α_y are coefficients given in Table 26,

w = total design load per unit area,

M_x, M_y = moments on strips of unit width spanning l_x and l_y respectively, and

l_x and l_y = lengths of the shorter span and longer span respectively.

D-1.2 Slabs are considered as divided in each direction into middle strips and edge strips as shown in Fig. 25 the middle strip being three-quarters of the width and each edge strip one-eighth of the width.

D-1.3 The maximum moments calculated as in D-1.1 apply only to the middle strips and no redistribution shall be made.

D-1.4 Tension reinforcement provided at mid-span in the middle strip shall extend in the lower part of the slab to within $0.25 l$ of a continuous edge, or $0.15 l$ of a discontinuous edge.

D-1.5 Over the continuous edges of a middle strip, the tension reinforcement shall extend in the upper part of the slab a distance of $0.15 l$ from the support, and at least 50 percent shall extend a distance of $0.3 l$.

D-1.6 At a discontinuous edge, negative moments may arise. They depend on the degree of fixity at the edge of the slab but, in general, tension reinforcement equal to 50 percent of that provided at mid-span extending $0.1 l$ into the span will be sufficient.

D-1.7 Reinforcement in edge strip, parallel to that edge, shall comply with the minimum given in Section 3 and the requirements for torsion given in D-1.8 to D-1.10.

D-1.8 Torsion reinforcement shall be provided at any corner where the slab is simply supported on both edges meeting at that corner. It shall consist of top and bottom reinforcement, each with layers of bars placed parallel to the sides of the slab and extending from the edges a minimum distance of one-fifth of the shorter span. The area of reinforcement in each of these four layers shall be three-quarters of the area required for the maximum mid-span moment in the slab.

D-1.9 Torsion reinforcement equal to half that described in D-1.8 shall be provided at a corner contained by edges over only one of which the slab is continuous.

D-1.10 Torsion reinforcements need not be provided at any corner contained by edges over both of which the slab is continuous.

D-1.11 Torsion l_y/l_x is greater than 2, the slabs shall be designed as spanning one way.

D-2 SIMPLY SUPPORTED SLABS

D-2.1 When simply supported slabs do not have adequate provision to resist torsion at corners and to prevent the corners from lifting, the maximum

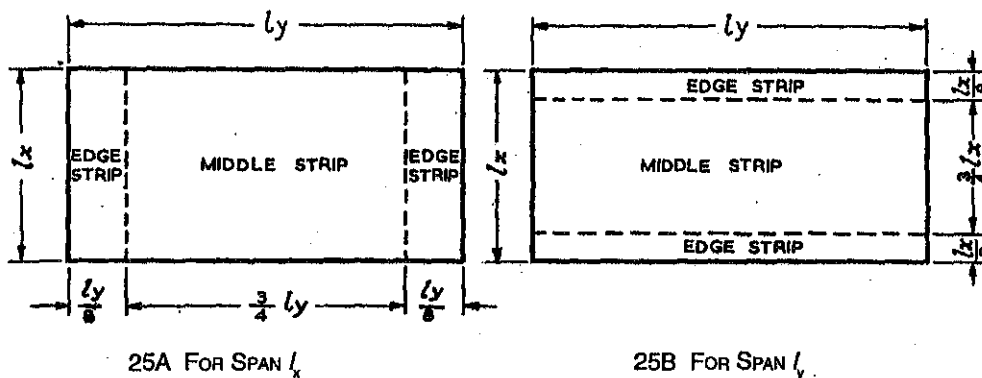

FIG. 25 DIVISION OF SLAB INTO MIDDLE AND EDGE STRIPS

Table 26 Bending Moment Coefficients for Rectangular Panels Supported on Four Sides with Provision for Torsion at Corners

(Clauses D-1.1 and 24.4.1)

Case No.	Type of Panel and Moments Considered	Short Span Coefficients α_x (Values of l_y/l_x)								Long Span Coefficients α_y for All Values of l_y/l_x
		1.0	1.1	1.2	1.3	1.4	1.5	1.75	2.0	
(1)	(2)	(3)	(4)	(5)	(6)	(7)	(8)	(9)	(10)	(11)
1	<i>Interior Panels:</i>									
	Negative moment at continuous edge	0.032	0.037	0.043	0.047	0.051	0.053	0.060	0.065	0.032
	Positive moment at mid-span	0.024	0.028	0.032	0.036	0.039	0.041	0.045	0.049	0.024
2	<i>One Short Edge Continuous:</i>									
	Negative moment at continuous edge	0.037	0.043	0.048	0.051	0.055	0.057	0.064	0.068	0.037
	Positive moment at mid-span	0.028	0.032	0.036	0.039	0.041	0.044	0.048	0.052	0.028
3	<i>One Long Edge Discontinuous:</i>									
	Negative moment at continuous edge	0.037	0.044	0.052	0.057	0.063	0.067	0.077	0.085	0.037
	Positive moment at mid-span	0.028	0.033	0.039	0.044	0.047	0.051	0.059	0.065	0.028
4	<i>Two Adjacent Edges Discontinuous:</i>									
	Negative moment at continuous edge	0.047	0.053	0.060	0.065	0.071	0.075	0.084	0.091	0.047
	Positive moment at mid-span	0.035	0.040	0.045	0.049	0.053	0.056	0.063	0.069	0.035
5	<i>Two Short Edges Discontinuous:</i>									
	Negative moment at continuous edge	0.045	0.049	0.052	0.056	0.059	0.060	0.065	0.069	—
	Positive moment at mid-span	0.035	0.037	0.040	0.043	0.044	0.045	0.049	0.052	0.035
6	<i>Two Long Edges Discontinuous:</i>									
	Negative moment at continuous edge	—	—	—	—	—	—	—	—	0.045
	Positive moment at mid-span	0.035	0.043	0.051	0.057	0.063	0.068	0.080	0.088	0.035
7	<i>Three Edges Discontinuous (One Long Edge Continuous):</i>									
	Negative moment at continuous edge	0.057	0.064	0.071	0.076	0.080	0.084	0.091	0.097	—
	Positive moment at mid-span	0.043	0.048	0.053	0.057	0.060	0.064	0.069	0.073	0.043
8	<i>Three Edges Discontinuous (One Short Edge Continuous):</i>									
	Negative moment at continuous edge	—	—	—	—	—	—	—	—	0.057
	Positive moment at mid-span	0.043	0.051	0.059	0.065	0.071	0.076	0.087	0.096	0.043
9	<i>Four Edges Discontinuous:</i>									
	Positive moment at mid-span	0.056	0.064	0.072	0.079	0.085	0.089	0.100	0.107	0.056

moments per unit width are given by the following equation:

$$M_x = \alpha_x w l_x^2$$

$$M_y = \alpha_y w l_y^2$$

where

M_x, M_y, w, l_x, l_y are same as those in D-1.1,

and α_x and α_y are moment coefficients given in Table 27

D-2.1.1 At least 50 percent of the tension reinforcement provided at mid-span should extend to the supports. The remaining 50 percent should extend to within 0.1 l_x or 0.1 l_y of the support, as appropriate.

Table 27 Bending Moment Coefficients for Slabs Spanning in Two Directions at Right Angles, Simply Supported on Four Sides

(Clause D-2.1)

l_y/l_x	1.0	1.1	1.2	1.3	1.4	1.5	1.75	2.0	2.5	3.0
α_x	0.062	0.074	0.084	0.093	0.099	0.104	0.113	0.118	0.122	0.124
α_y	0.062	0.061	0.059	0.055	0.051	0.046	0.037	0.029	0.020	0.014

ANNEX E

(Clause 25.2)

EFFECTIVE LENGTH OF COLUMNS

E-1 In the absence of more exact analysis, the effective length of columns in framed structures may be obtained from the ratio of effective length to unsupported length l_{ef}/l given in Fig. 26 when relative displacement of the ends of the column is prevented and in Fig. 26 when relative lateral displacement of the ends is not prevented. In the latter case, it is recommended that the effective length ratio l_{ef}/l may not be taken to be less than 1.2.

E-2 To determine whether a column is a no sway or a sway column, stability index Q may be computed as given below :

$$Q = \frac{\sum P_u \Delta_u}{H_u h_s}$$

where

$\sum P_u$ = sum of axial loads on all column in the storey,

Δ_u = elastically computed first order lateral deflection,

H_u = total lateral force acting within the storey, and

h_s = height of the storey.

NOTES

1 Figures 26 and 27 are reproduced from 'The Structural Engineer' No. 7, Volume 52, July 1974 by the permission of the Council of the Institution of Structural Engineers, U.K.

2 In Figs. 26 and 27, β_1 and β_2 are equal to $\frac{\sum K_c}{\sum K_c + \sum K_b}$

where the summation is to be done for the members framing into a joint at top and bottom respectively; and K_c and K_b being the flexural stiffness for column and beam respectively.

If $Q \leq 0.04$, then the column in the frame may be taken as no sway column, otherwise the column will be considered as sway column.

E-3 For normal usage assuming idealized conditions, the effective length l_{ef} of in a given plane may be assessed on the basis of Table 28.

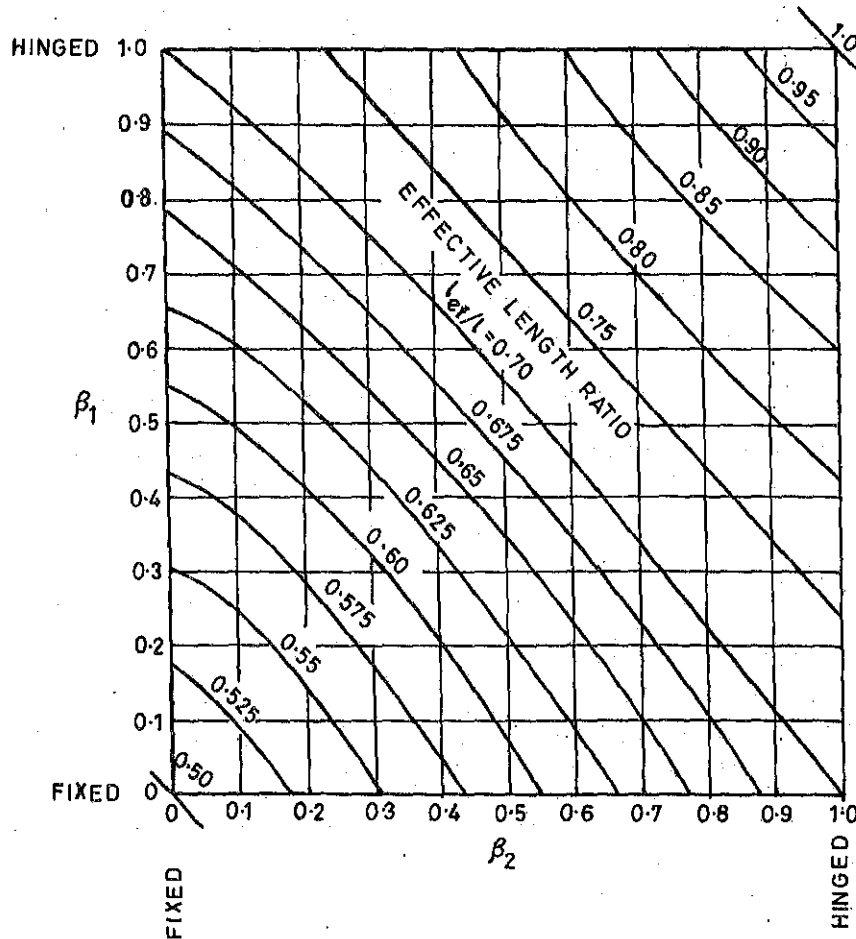

FIG. 26 EFFECTIVE LENGTH RATIOS FOR A COLUMN IN A FRAME WITH NO SWAY

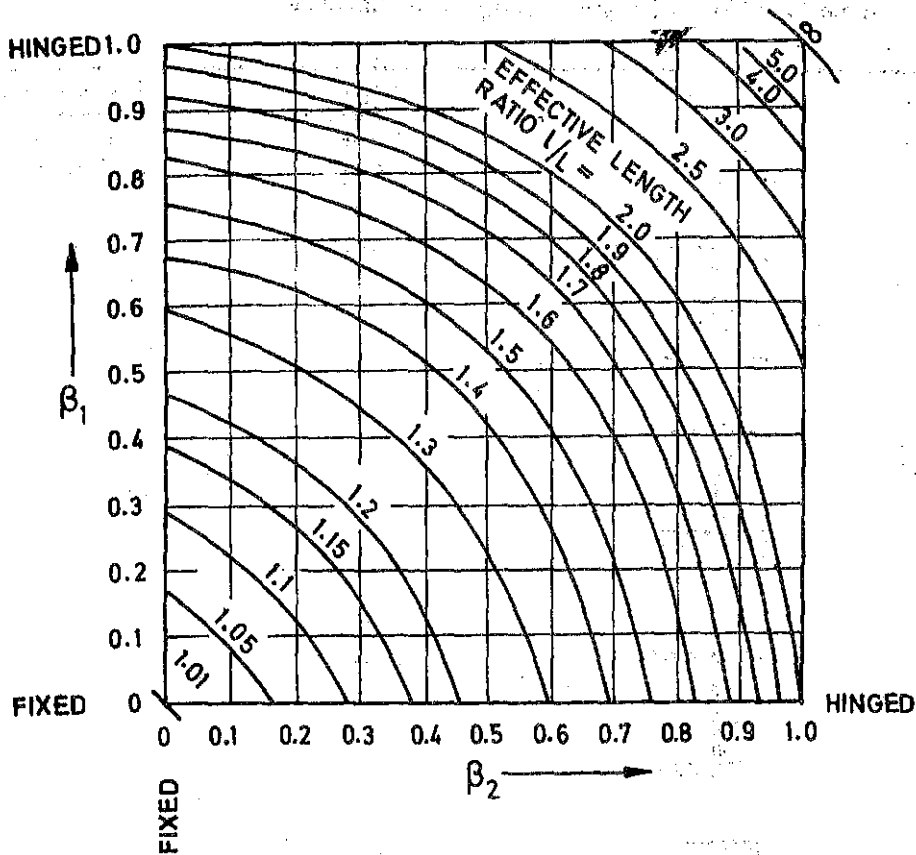
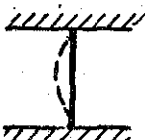
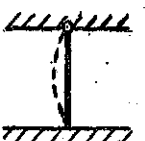
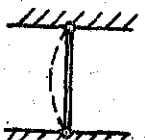

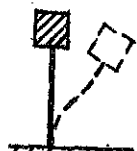
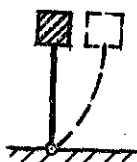
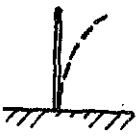

FIG. 27 EFFECTIVE LENGTH RATIOS FOR A COLUMN IN A FRAME WITHOUT RESTRAINT AGAINST SWAY

Table 28 Effective Length of Compression Members
(Clause E-3)

Degree of End Restraint of Compression Members	Symbol	Theoretical Value of Effective Length	Recommended Value of Effective Length
(1)	(2)	(3)	(4)
Effectively held in position and restrained against rotation in both ends		0.50 <i>l</i>	0.65 <i>l</i>
Effectively held in position at both ends, restrained against rotation at one end		0.70 <i>l</i>	0.80 <i>l</i>
Effectively held in position at both ends, but not restrained against rotation		1.00 <i>l</i>	1.00 <i>l</i>
Effectively held in position and restrained against rotation at one end, and at the other restrained against rotation but not held in position		1.00 <i>l</i>	1.20
Effectively held in position and restrained against rotation in one end, and at the other partially restrained against rotation but not held in position			1.50 <i>l</i>
Effectively held in position at one end but not restrained against rotation, and at the other end restrained against rotation but not held in position		2.00 <i>l</i>	2.00 <i>l</i>
Effectively held in position and restrained against rotation at one end but not held in position nor restrained against rotation at the other end		2.00 <i>l</i>	2.00 <i>l</i>

NOTE — *l* is the unsupported length of compression member.

ANNEX F

(Clauses 35.3.2 and 43.1)

CALCULATION OF CRACK WIDTH

Provided that the strain in the tension reinforcement is limited to $0.8 F_y/E_s$, the design surface crack width, which should not exceed the appropriate value given in 35.3.2 may be calculated from the following equation:

Design surface crack width

$$W_{cr} = \frac{3 a_{cr} \varepsilon_m}{1 + \frac{2(a_{cr} - C_{min})}{h - x}}$$

where

a_{cr} = distance from the point considered to the surface of the nearest longitudinal bar,

C_{min} = minimum cover to the longitudinal bar;

ε_m = average steel strain at the level considered,

h = overall depth of the member, and

x = depth of the neutral axis.

The average steel strain ε_m may be calculated on the basis of the following assumption:

The concrete and the steel are both considered to be fully elastic in tension and in compression. The elastic modulus of the steel may be taken as 200 kN/mm² and the elastic modulus of the concrete is as derived from the equation given in 6.2.3.1 both in compression and in tension.

These assumptions are illustrated in Fig. 28,

where

h = the overall depth of the section,

x = the depth from the compression face to the neutral axis,

f_c = the maximum compressive stress in the concrete,

f_s = the tensile stress in the reinforcement, and

E_s = the modulus of elasticity of the reinforcement.

Alternatively, as an approximation, it will normally be satisfactory to calculate the steel stress on the basis of a cracked section and then reduce this by an amount equal to the tensile force generated by the triangular distributions, having a value of zero at the neutral axis and a value at the centroid of the tension steel of 1N/mm² instantaneously, reducing to 0.55 N/mm² in the long-term, acting over the tension zone divided by the steel area. For a rectangular tension zone, this gives

$$\varepsilon_m = \varepsilon_1 - \frac{b (h-x)(a-x)}{3 E_s A_s (d-x)}$$

where

A_s = area of tension reinforcement,

b = width of the section at the centroid of the tension steel,

ε_1 = strain at the level considered, calculated ignoring the stiffening of the concrete in the tension zone,

a = distance from the compression face to the point at which the crack width is being calculated, and

d = effective depth.

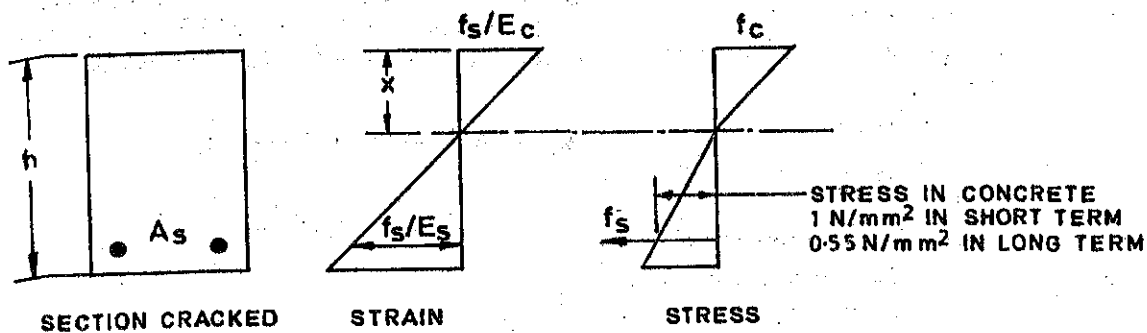

FIG. 28

ANNEX G

(Clause 38.1)

MOMENTS OF RESISTANCE FOR RECTANGULAR AND T-SECTIONS

G-0 The moments of resistance of rectangular and T-sections based on the assumptions of 38.1 are given in this annex.

G-1 RECTANGULAR SECTIONS**G-1.1 Sections Without Compression Reinforcement**

The moment of resistance of rectangular sections without compression reinforcement should be obtained as follows :

- a) Determine the depth of neutral axis from the following equation :

$$\frac{x_u}{d} = \frac{0.87 f_y A_{st}}{0.36 f_{ck} b d}$$

- b) If the value of x_u/d is less than the limiting value (see Note below 38.1), calculate the moment of resistance by the following expression :

$$M_u = 0.87 f_y A_{st} d \left(1 - \frac{A_{st} f_y}{b d f_{ck}} \right)$$

- c) If the value of x_u/d is equal to the limiting value, the moment of resistance of the section is given by the following expression :

$$M_{u,lim} = 0.36 \frac{x_{u,max}}{d} \left(1 - 0.42 \frac{x_{u,max}}{d} \right) b d^2 f_{ck}$$

- d) If x_u/d is greater than the limiting value, the section should be redesigned.

In the above equations,

- x_u = depth of neutral axis,
 d = effective depth,
 f_y = characteristic strength of reinforcement,
 A_{st} = area of tension reinforcement,
 f_{ck} = characteristic compressive strength of concrete,
 b = width of the compression face,
 $M_{u,lim}$ = limiting moment of resistance of a section without compression reinforcement, and
 $x_{u,max}$ = limiting value of x_u from 39.1.

G-1.2 Section with Compression Reinforcement

Where the ultimate moment of resistance of section

exceeds the limiting value, $M_{u,lim}$ compression reinforcement may be obtained from the following equation :

$$M_u - M_{u,lim} = f_{sc} A_{sc} (d - d')$$

where

$M_u, M_{u,lim}, d$ are same as in G-1.1,

f_{sc} = design stress in compression reinforcement corresponding to a strain of

$$0.0035 \frac{(x_{u,max} - d')}{x_{u,max}}$$

where

$x_{u,max}$ = the limiting value of x_u from 38.1,

A_{sc} = area of compression reinforcement, and

d' = depth of compression reinforcement from compression face.

The total area of tension reinforcement shall be obtained from the following equation :

$$A_{st} = A_{st1} + A_{st2}$$

where

A_{st} = area of the total tensile reinforcement,

A_{st1} = area of the tensile reinforcement for a singly reinforced section for $M_{u,lim}$, and

$$A_{st2} = A_{sc} f_{sc} / 0.87 f_y$$

G-2 FLANGED SECTION

G-2.1 For $x_u < D_f$, the moment of resistance may be calculated from the equation given in G-1.1.

G-2.2 The limiting value of the moment of resistance of the section may be obtained by the following equation when the ratio D_f/d does not exceed 0.2 :

$$M_u = 0.36 \frac{x_{u,max}}{d} \left(1 - 0.42 \frac{x_{u,max}}{d} \right) f_{ck} b_w d^2 + 0.45 f_{ck} (b_f - b_w) D_f \left(d - \frac{D_f}{2} \right)$$

where

$M_u, x_{u,max}, d$ and f_{ck} are same as in G-1.1,

b_f = breadth of the compression face/flange,

b_w = breadth of the web, and

D_f = thickness of the flange.

G-2.2.1 When the ratio D_f/d exceeds 0.2, the moment of resistance of the section may be calculated by the following equation :

$$M_u = 0.36 \frac{x_{u,\max}}{d} \left(1 - 0.42 \frac{x_{u,\max}}{d} \right) f_{ck} b_w d^2 + 0.45 f_{ck} (b_f - b_w) y_f \left(d - \frac{y_f}{2} \right)$$

where $y_f = (0.15 x_u + 0.65 D_f)$, but not greater than D_f , and the other symbols are same as in **G-1.1** and **G-2.2**.

G-2.3 For $x_{u,\max} > x_u > D_f$, the moment of resistance may be calculated by the equations given in **G-2.2** when D_f/x_u does not exceed 0.43 and **G-2.2.1** when D_f/x_u exceeds 0.43; in both cases substituting $x_{u,\max}$ by x_u .

Civil Junction

ANNEX H

(Foreword)

COMMITTEE COMPOSITION

Cement and Concrete Sectional Committee, CED 2

Chairman

DR H. C. VISVESVARAYA
 'Chandrika', at 15th Cross,
 63-64, Malleswaram, Bangalore 560 003

<i>Members</i>	<i>Representing</i>
DR S. C. AHLUWALIA	OCL India, New Delhi
SHRI G. R. BHARTIKAR	B. G. Shirke & Construction Technology Ltd, Pune
SHRI T. N. TIWARI	The Associated Cement Companies Ltd, Mumbai
DR D. GHOSH (<i>Alternate</i>)	Central Public Works Department, New Delhi
CHIEF ENGINEER (DESIGN)	Sardar Sarovar Narman Nigam Ltd, Gandhinagar
SUPERINTENDING ENGINEER (S&S) (<i>Alternate</i>)	
CHIEF ENGINEER, NAVAGAM DAM	
SUPERINTENDING ENGINEER (QCC) (<i>Alternate</i>)	
CHIEF ENGINEER (RESEARCH-CUM-DIRECTOR)	Irrigation and Power Research Institute, Amritsar
RESEARCH OFFICER (CONCRETE TECHNOLOGY) (<i>Alternate</i>)	
DIRECTOR	A.P. Engineering Research Laboratories, Hyderabad
JOINT DIRECTOR (<i>Alternate</i>)	
DIRECTOR (CMDD) (N&W)	Central Water Commission, New Delhi
DEPUTY DIRECTOR (CMDD) (NW&S) (<i>Alternate</i>)	
SHRI K. H. GANGWAL	Hyderabad Industries Ltd, Hyderabad
SHRI V. PATTABHI (<i>Alternate</i>)	
SHRI V. K. GHANEKAR	Structural Engineering Research Centre (CSIR), Ghaziabad
SHRI S. GOPINATH	The India Cements Ltd, Chennai
SHRI R. TAMBAKARAN (<i>Alternate</i>)	
SHRI S. K. GUHA THAKURTA	Gannon Dunkerley & Co Ltd, Mumbai
SHRI S. P. SANKARANARAYANAN (<i>Alternate</i>)	
SHRI N. S. BHAL	Central Building Research Institute (CSIR), Roorkee
DR IRSHAD MASOOD (<i>Alternate</i>)	
SHRI N. C. JAIN	Cement Corporation of India, New Delhi
JOINT DIRECTOR STANDARDS (B&S) (CB-I)	Research, Designs & Standards Organization (Ministry of Railway),
JOINT DIRECTOR STANDARDS (B&S) (CB-II) (<i>Alternate</i>)	Lucknow
SHRI N. G. JOSHI	Indian Hume Pipes Co Ltd, Mumbai
SHRI P. D. KELKAR (<i>Alternate</i>)	
SHRI D. K. KANUNGO	National Test House, Calcutta
SHRI B.R. MEENA (<i>Alternate</i>)	
SHRI P. KRISHNAMURTHY	Larsen and Toubro Limited, Mumbai
SHRI S. CHAKRAVARTHY (<i>Alternate</i>)	
DR A. G. MADHAVA RAO	Structural Engineering Research Centre (CSIR), Chennai
SHRI K. MANI (<i>Alternate</i>)	
SHRI J. SARUP	Hospital Services Consultancy Corporation (India) Ltd, New Delhi
SHRI PRAFULLA KUMAR	Ministry of Surface Transport, Department of Surface Transport
SHRI P. P. NAIR (<i>Alternate</i>)	(Roads Wing), New Delhi

(Continued on page 99)

(Continued from page 98)

<i>Members</i>	<i>Representing</i>
MEMBER SECRETARY DIRECTOR (CIVIL) (<i>Alternate</i>)	Central Board of Irrigation and Power, New Delhi
SHRI S. K. NATHANI, SO I DR A. S. GOEL, EE (<i>Alternate</i>)	Engineer-in-Chief's Branch, Army Headquarters, New Delhi
SHRI S. S. SEBHRA SHRI SATANDER KUMAR (<i>Alternate</i>)	Central Road Research Institute (CSIR), New Delhi
SHRI Y. R. PHULL SHRI A. K. SHARMA (<i>Alternate</i>)	Indian Roads Congress, New Delhi
DR C. RAJKUMAR DR K. MOHAN (<i>Alternate</i>)	National Council for Cement and Building Materials, New Delhi
SHRI G. RAMDAS SHRI R. C. SHARMA (<i>Alternate</i>)	Directorate General of Supplies and Disposals, New Delhi
SHRI S. A. REDDI	Gammon India Ltd, Mumbai
SHRI J. S. SANGANERIA SHRI L. N. AGARWAL (<i>Alternate</i>)	Geological Survey of India, Calcutta
SHRI VENKATACHALAM SHRI N. CHANDRASEKARAN (<i>Alternate</i>)	Central Soil and Materials Research Station, New Delhi
SUPERINTENDING ENGINEER (DESIGN) EXECUTIVE ENGINEER (S.M.R.DIVISION) (<i>Alternate</i>)	Public Works Department, Government of Tamil Nadu, Chennai
SHRI A. K. CHADHA SHRI J. R. SIL (<i>Alternate</i>)	Hindustan Prefab Ltd, New Delhi
DR H. C. VISVESVARAYA SHRI D. C. CHATURVEDI (<i>Alternate</i>)	The Institution of Engineers (India), Calcutta
SHRI VINOD KUMAR Director (Civ Engg)	Director General, BIS (<i>Ex-officio Member</i>)

Member-Secretaries

SHRI J. K. PRASAD
Addl Director (Civ Engg), BIS
SHRI SANJAY PANT
Deputy Director (Civ Engg), BIS

Panel for Revision of Design Codes

<i>Convener</i>	
DR C. RAJKUMAR	National Council for Cement and Building Materials, Ballabgarh
<i>Members</i>	
SHRI V. K. GHANEKAR	Structural Engineering Research Centre, Ghaziabad
SHRI S. A. REDDI	Gammon India Ltd, Mumbai
SHRI JOSE KURIAN	Central Public Works Department, New Delhi
DR A. K. MITTAL	Central Public Works Department, New Delhi
DR S. C. MAITI	National Council for Cement and Building Materials, Ballabgarh
DR ANIL KUMAR (<i>Alternate</i>)	
PROF A.K. JAIN	University of Roorkee, Roorkee
DR V. THIRUVENGDM	School of Planning and Architecture, New Delhi

(Continued on page 100)

Special Ad-Hoc Group for Revision of IS 456

Convener

DR. H.C. VISVESVARAYA
'Chandrika' at 15th Cross,
63-64, Malleswaram, Bangalore 560 003

Members

SHRI S.A. REDDI

DR. C. RAJKUMAR

Representing

Gammon India Ltd, Mumbai

National Council for Cement and Building Materials, Ballabgarh

Bureau of Indian Standards

BIS is a statutory institution established under the *Bureau of Indian Standards Act, 1986* to promote harmonious development of the activities of standardization, marking and quality certification of goods and attending to connected matters in the country.

Copyright

BIS has the copyright of all its publications. No part of these publications may be reproduced in any form without the prior permission in writing of BIS. This does not preclude the free use, in the course of implementing the standard, of necessary details, such as symbols and sizes, type or grade designations. Enquiries relating to copyright be addressed to the Director (Publications), BIS.

Review of Indian Standards

Amendments are issued to standards as the need arises on the basis of comments. Standards are also reviewed periodically; a standard along with amendments is reaffirmed when such review indicates that no changes are needed; if the review indicates that changes are needed, it is taken up for revision. Users of Indian Standards should ascertain that they are in possession of the latest amendments or edition by referring to the latest issue of 'BIS Catalogue' and 'Standards : Monthly Additions'.

This Indian Standard has been developed from Doc No.: CED 2(5525).

Amendments Issued Since Publication

Amend No.	Date of Issue	Text Affected

BUREAU OF INDIAN STANDARDS

Headquarters:

Manak Bhavan, 9 Bahadur Shah Zafar Marg, New Delhi 110002
Telephones : 2323 0131, 2323 3375, 2323 9402 Website: www.bis.org.in

Regional Offices:

	Telephones
Central : Manak Bhavan, 9 Bahadur Shah Zafar Marg NEW DELHI 110002	{ 2323 7617 2323 3841
Eastern : 1/14 C.I.T. Scheme VII M, V. I. P. Road, Kankurgachi KOLKATA 700054	{ 2337 8499, 2337 8561 2337 8626, 2337 9120
Northern : SCO 335-336, Sector 34-A, CHANDIGARH 160022	{ 60 3843 60 9285
Southern : C.I.T. Campus, IV Cross Road, CHENNAI 600113	{ 2254 1216, 2254 1442 2254 2519, 2254 2315
Western : Manakalaya, E9 MIDC, Marol, Andheri (East) MUMBAI 400093	{ 2832 9295, 2832 7858 2832 7891, 2832 7892

Branches: AHMEDABAD. BANGALORE. BHOPAL. BHUBANESHWAR. COIMBATORE. DEHRADUN.
FARIDABAD. GHAZIABAD. GUWAHATI. HYDERABAD. JAIPUR. KOCHI. LUCKNOW.
NAGPUR. PARWANOO. PATNA. PUNE. RAJKOT. VISAKHAPATNAM.

Published by BIS, New Delhi

AMENDMENT NO. 1 JUNE 2001
TO
IS 456 : 2000 PLAIN AND REINFORCED CONCRETE — CODE OF PRACTICE
(Fourth Revision)

(Page 2, Foreword, last but one line) — Substitute 'ACI 318 : 1995' for 'ACI 319 : 1989'.

(Page 11, clause 4) — Delete the matter ' L_w — Horizontal distance between centres of lateral restraint'.

(Page 15, clause 5.5, Title) — Substitute 'Chemical Admixtures' for 'Admixtures'.

(Page 17, clause 7.1) — Substitute the following for the existing informal table:

<i>Placing Conditions</i>	<i>Degree of Workability</i>	<i>Slump (mm)</i>
(1)	(2)	(3)
Blinding concrete; Shallow sections; Pavements using pavers	Very low	See 7.1.1
Mass concrete; Lightly reinforced sections in slabs, beams, walls, columns; Floors; Hand placed pavements; Canal lining; Strip footings	Low	25-75
Heavily reinforced sections in slabs, beams, walls, columns;	Medium	50-100
Slipform work; Pumped concrete	Medium	75-100
Trench fill; <i>In-situ</i> piling	High	100 -150
Tremie concrete	Very high	See 7.1.2

NOTE — For most of the placing conditions, internal vibrators (needle vibrators) are suitable. The diameter of the needle shall be determined based on the density and spacing of reinforcement bars and thickness of sections. For tremie concrete, vibrators are not required to be used (see also 13.3).

(Page 19, Table 4, column 8, sub-heading) — Substitute 'Free' for 'Face'.

(Page 27, clause 13.5.3) — Delete.

(Page 29, clause 15.3):

a) Substitute 'specimens' for 'samples' in lines 2, 6 and 7.

b) Substitute 'IS 9013' for 'IS 9103'.

(Page 29, clause 16.1) — Substitute 'conditions' for 'condition' in line 3 and the following matter for the existing matter against 'a)':

'a) The mean strength determined from any group of four non-overlapping consecutive test results complies with the appropriate limits in column 2 of Table 11.'

(Page 29, clause 16.3, para 2) — Substitute 'col 3' for 'col 2'.

(Page 29, clause 16.4, line 2) — Substitute '16.1 or 16.2 as the case may be' for '16.3'.

(Page 30, Table 11, column 3) — Substitute ' $\geq f_{ck} - 3$ ' for ' $\geq f_{ck}^{-3}$ ', and ' $\geq f_{ck} - 4$ ' for ' $\geq f_{ck}^{-4}$ '.

(Page 33, clause 21.3, line 2) — Substitute 'action' for 'section'.

[Page 37, clause 23.1.2(c)] — Substitute ' b_t ' for ' b_t ', ' l_0 ' for ' l_0 ', ' b ' for ' b ' and ' b_w ' for ' b_w ' in the formulae.

(Page 46, clause 26.4.2) — Substitute '8.2.2' for '8.2.3'.

[Page 49, clause 26.5.3.2 (c) (2), last line] — Substitute '6 mm' for '16 mm'.

(Page 62, clause 32.2.5) — Substitute ' H_{we}^2 ' for ' H_{we} ' in the explanation of e_s .

(Page 62, clause 32.3.1, line 4) — Substitute '32.4' for '32.3'.

[Page 62, clause 32.4.3 (b), line 6] — Insert ' τ_{sw} ' between the words 'but' and 'shall'.

[Page 65, clause 34.2.4.1(a), last line] — Insert the following after the words 'depth of footing' :

'in case of footings on soils, and at a distance equal to half the effective depth of footing'.

(Page 68, Table 18, col 4) — Substitute '-' for '1.0' against the Load Combination $DL + IL$.

(Page 72, clause 40.1) — Substitute ' bd ' for ' b_d ' in the formula.

(Page 83, clause B-4.3, line 2) — Delete the word 'and' .

(Page 85, clause B-5.5.1, para 2, line 6) — Substitute 'Table 24' for 'Table 23'.

(Page 85, clause B-5.5.2) — Substitute the following for the existing formula:

$$A_s = a_v b (\tau_c - 2d \tau_c / a_v) / \sigma_{sv} \geq 0.4 a_v b / 0.87 f_y$$

(Page 90, clause D-1.11, line 1) — Substitute 'Where' for 'Torsion'.

(Page 93, Fig. 27) — Substitute ' l_e/l ' for ' l/L '.

(Page 95, Annex F):

- a) The reference to Fig. 28 given in column 1 of the text along with the explanation of the symbols used in the Fig. 28 given thereafter may be read just before the formula given for the rectangular tension zone.
- b) Substitute 'compression' for 'campression' in the explanation of symbol 'a' .

(Pages 98 to 100, Annex H) — Substitute the following for the existing Annex :

ANNEX H

(Foreword)

COMMITTEE COMPOSITION

Cement and Concrete Sectional Committee, CED 2

Chairman

DR H. C. VISVESVARAYA
'Chandrika', at 15th Cross, 63-64 East Park Road,
Malleswaram, Bangalore-560 003

Members

DR S. C. AHLUWALIA

SHRI V. BALASUBRAMANIAN
SHRI R. P. SINGH (Alternate)

SHRI G. R. BHARTIKAR

SHRI A. K. CHADHA
SHRI J. R. SIL (Alternate)

CHIEF ENGINEER (DESIGN)
SUPERINTENDING ENGINEER (S&S) (Alternate)

CHIEF ENGINEER (NAVGAM DAM)
SUPERINTENDING ENGINEER (QCC) (Alternate)

CHIEF ENGINEER (RESEARCH)-CUM-DIRECTOR
RESEARCH OFFICER (CONCRETE TECHNOLOGY)
(Alternate)

Representing

OCL India Ltd, New Delhi

Directorate General of Supplies and Disposals, New Delhi

B. G. Shirke Construction Technology Ltd, Pune

Hindustan Prefab Limited, New Delhi

Central Public Works Department, New Delhi

Sardar Sarovar Narmada Nigam Ltd, Gandhinagar

Irrigation and Power Research Institute, Amritsar

(Continued from page 2)

<i>Members</i>	<i>Representing</i>
SHRI J. P. DESAI SHRI B. K. JAGTIA (Alternate)	Gujarat Ambuja Cements Ltd, Ahmedabad
DIRECTOR JOINT DIRECTOR (Alternate)	A.P. Engineering Research Laboratories, Hyderabad
DIRECTOR (CMDD) (N&W) DEPUTY DIRECTOR (CMDD) (NW&S) (Alternate)	Central Water Commission, New Delhi
SHRI K. H. GANGWAL SHRI V. PATTABHI (Alternate)	Hyderabad Industries Ltd, Hyderabad
SHRI V. K. GHANEKAR	Structural Engineering Research Centre (CSIR), Ghaziabad
SHRI S. GOPINATH SHRI R. TAMILAKARAN (Alternate)	The India Cements Ltd, Chennai
SHRI S. K. GUHA THAKURTA SHRI S. SANKARANARAYANAN (Alternate)	Gannon Dunkerley and Company Ltd, Mumbai
SHRI N. S. BHAL DR IRSHAD MASOOD (Alternate)	Central Building Research Institute (CSIR), Roorkee
PROF A. K. JAIN	University of Roorkee, Roorkee
SHRI N. C. JAIN	Cement Corporation of India Ltd, New Delhi
JOINT DIRECTOR (STANDARDS) (B&S) (CB-I) JOINT DIRECTOR (STANDARDS) (B&S) (CB-II) (Alternate)	Research, Designs & Standards Organization (Ministry of Railways), Lucknow
SHRI N. G. JOSHI SHRI P. D. KELKAR (Alternate)	The Indian Hume Pipe Company Ltd, Mumbai
SHRI D. K. KANUNGO SHRI B. R. MEENA (Alternate)	National Test House, Calcutta
SHRI P. KRISHNAMURTHY SHRI S. CHOWDHURY (Alternate)	Larsen & Tubro Ltd, Mumbai
DR A. G. MADHAVA RAO SHRI K. MANI (Alternate)	Structural Engineering Research Centre (CSIR), Chennai
SHRI J. SARUP	Hospital Services Consultancy Corporation (India) Ltd, New Delhi
SHRI V. SURESH SHRI D. P. SINGH (Alternate)	Housing and Urban Development Corporation Ltd, New Delhi
SHRI PRAFFULA KUMAR SHRI P. P. NAIR (Alternate)	Ministry of Surface Transport, Department of Surface Transport (Roads Wing), New Delhi
MEMBER SECRETARY DIRECTOR (CIVIL) (Alternate)	Central Board of Irrigation & Power, New Delhi
SHRI S. K. NATHANI DR A. S. GOEL (Alternate)	Engineer-in-Chief's Branch, Army Headquarters, New Delhi
SHRI S. S. SEEHRA SHRI SATANDER KUMAR (Alternate)	Central Road Research Institute (CSIR), New Delhi
SHRI Y. R. PHULL SHRI A. K. SHARMA (Alternate)	Indian Roads Congress, New Delhi
DR C. RAJKUMAR DR K. MOHAN (Alternate)	National Council for Cement and Building Materials, Ballabgarh
SHRI S. A. REDDI	Gammon India Ltd, Mumbai
REPRESENTATIVE	Builder's Association of India, Mumbai
SHRI J. S. SANGANERIA SHRI L. N. AGARWAL (Alternate)	Geological Survey of India, Calcutta
SUPERINTENDING ENGINEER (DESIGN) EXECUTIVE ENGINEER (SMR DIVISION) (Alternate)	Public Works Department, Government of Tamil Nadu, Chennai
SHRI K. K. TAPARIA SHRI A. K. JAIN (Alternate)	Indian Rayon and Industries Ltd, Pune
SHRI T. N. TIWARI DR D. GHOSH (Alternate)	The Associated Cement Companies Ltd, Mumbai
DR K. VENKATACHALAM SHRI N. CHANDRASEKARAN (Alternate)	Central Soil and Materials Research Station, New Delhi

(Continued from page 3)

Members

DR H. C. VISVESVARAYA
SHRI D. C. CHATURVEDI (Alternate)
SHRI VINOD KUMAR
Director (Civ Engg)

Representing

The Institution of Engineers (India), Calcutta
Director General, BIS (Ex-officio Member)

Member-Secretaries

SHRI J. K. PRASAD
Additional Director (Civ Engg), BIS
SHRI SANJAY PANT
Deputy Director (Civ Engg), BIS

Concrete Subcommittee, CED 2:2

Convener

DR A. K. MULLICK

Representing

National Council for Cement and Building Materials, Ballabgarh

Members

SHRI C. R. ALIMCHANDANI
SHRI S. RANGARAJAN (Alternate)

Stup Consultants Ltd, Mumbai

DR P. C. CHOWDHURY
DR C. S. VISHWANATHA (Alternate)

Torsteel Research Foundation in India, Calcutta

SHRI J. P. DESAI
SHRI B. K. JAGTIA (Alternate)

Gujarat Ambuja Cements Ltd, Ahmedabad

DIRECTOR
SHRI N. CHANDRASEKARAN (Alternate)

Central Soil and Materials Research Station, New Delhi

DIRECTOR (C&MDD)
DEPUTY DIRECTOR (C&MDD) (Alternate)

Central Water Commission, New Delhi

JOINT DIRECTOR STANDARDS (B&S)/CB-II
JOINT DIRECTOR STANDARDS (B&S)/CB-I
(Alternate)

Research, Designs and Standards Organization (Ministry of Railways), Lucknow

SUPERINTENDING ENGINEER (DESIGNS)
EXECUTIVE ENGINEER (DESIGNS)-III (Alternate)

Central Public Works Department, New Delhi

SHRI V. K. GHANEKAR
SHRI D. S. PRAKASH RAO (Alternate)

Structural Engineering Research Centre (CSIR), Ghaziabad

SHRI S. K. GUHA THAKURTA
SHRI S. P. SANKARANARAYANAN (Alternate)

Gannon Dunkerley and Co Ltd, Mumbai

SHRI J. S. HINGORANI

Associated Consulting Services, Mumbai

SHRI L. K. JAIN

In personal capacity

SHRI M. P. JAISINGH
DR B. KAMESWARA RAO (Alternate)

Central Building Research Institute (CSIR), Roorkee

CHIEF ENGINEER & JOINT SECRETARY
SUPERINTENDING ENGINEER (Alternate)

Public Works Department, Mumbai

PROF S. KRISHNA MOORTHY
SHRI K. K. NAYAR (Alternate)

Indian Institute of Technology, New Delhi

DR S. C. MAITI

National Council for Cement and Building Materials, Ballabgarh

MANAGING DIRECTOR
SHRI M. KUNDU (Alternate)

Hindustan Prefab Limited, New Delhi

SHRI S. K. NATHANI
LT-COL K. S. CHARAK (Alternate)

Engineer-in-Chief's Branch, Army Headquarters, New Delhi

SHRI B. V. B. PAI
SHRI M. G. DANDVATE (Alternate)

The Associated Cement Companies Ltd, Mumbai

SHRI A. B. PHADKE
SHRI D. M. SAVUR (Alternate)

The Hindustan Construction Co Ltd, Mumbai

SHRI Y. R. PHULL
SHRI S. S. SEBHRA (Alternate I)
SHRI SATANDER KUMAR (Alternate II)

Central Road Research Institute (CSIR), New Delhi

(Continued from page 4)

Members

SHRI A. S. PRASAD RAO
SHRI K. MANI (Alternate)

SHRI K. L. PRUTHI
SHRI J. R. GABRIEL (Alternate)

SHRI B. D. RAHALKER
SHRI U. S. P. VERMA (Alternate)

SHRI HANUMANTHA RAO
SHRI G. RAMAKRISHNAN (Alternate)

SHRI S. A. REDDI
DR N. K. NAYAK (Alternate)

SHRI S. C. SAWHNEY
SHRI R. P. MEHROTRA (Alternate)

PROF M. S. SHETTY

SHRI N. K. SINHA

SHRI B. T. UNWALLA

Representing

Structural Engineering Research Centre (CSIR), Chennai

National Building Construction Corporation Ltd, New Delhi

Nuclear Power Corporation, Mumbai

A.P. Engineering Research Laboratories, Hyderabad

Gammon India Ltd, Mumbai

Engineers India Ltd, New Delhi

Indian Concrete Institute, Chennai

Ministry of Surface Transport (Roads Wing), New Delhi

In personal capacity

Panel for Revision of IS 456, CED 2:2/P

Convener

DR C. RAJKUMAR

Members

DR ANIL KUMAR

SHRI V. K. GHANEKAR

PROF A. K. JAIN

SHRI L. K. JAIN

SHRI JOSE KURIAN

DR S. C. MITTAL

DR A. K. MITTAL

SHRI S. A. REDDI

DR V. THIRUVENG DAM

Representing

National Council for Cement and Building Materials, Ballabgarh

National Council for Cement and Building Materials, Ballabgarh

Structural Engineering Research Centre (CSIR), Ghaziabad

University of Roorkee, Roorkee

In personal capacity

Central Public Works Department, New Delhi

National Council for Cement and Building Materials, Ballabgarh

Central Public Works Department, New Delhi

Gammon India Ltd, Mumbai

School of Planning and Architecture, New Delhi

Special Ad-Hoc Group for Revision of IS 456

Convener

DR H. C. VISVESVARAYA
'Chandrika', at 15th Cross, 63-64 East Park Road,
Malleswaram, Bangalore-560 003

Members

DR C. RAJKUMAR

SHRI S. A. REDDI

Representing

National Council for Cement and Building Materials, Ballabgarh

Gammon India Ltd, Mumbai

(CED 2)

AMENDMENT NO. 2 SEPTEMBER 2005
TO
IS 456 : 2000 PLAIN AND REINFORCED CONCRETE —
CODE OF PRACTICE
(Fourth Revision)

(Page 13, clause 5.2.1.1, line 1) — Substitute 'IS 3812 (Part 1)' for 'Grade 1 of IS 3812'.

(Page 13, clause 5.2.1.2 and corresponding Note) — Substitute the following for the existing:

'Silica fume conforming to IS 15388 may be used as part replacement of cement provided uniform blending with the cement is ensured.'

NOTE — Silica fume is usually used in proportion of 5 to 10 percent of the cement content of a mix.'

(Page 13, Note under clause 5.2.1.3, line 5) — Substitute 'be' for 'range from being'.

(Page 25, clause 10.3.3, line 4) — Delete the word 'and'.

(Page 65, clause 34.2.4.2, line 1) — Substitute 'on' for 'or'.

[Page 65, clause 34.3.1(a), line 2] — Delete the words 'extending in each direction'.

(Page 66, clause 34.4.3, line 5) — Substitute 'not' for 'no'.

(Page 78, Annex A) — Substitute the following for the existing entries for IS 3812 : 1981:

<i>'IS No.</i>	<i>Title</i>
IS 3812 (Part 1) : 2003	Specification for pulverized fuel ash : Part 1 For use as pozzolana in cement, cement mortar and concrete (<i>second revision</i>)'

(Page 79, Annex A) — Add the following at the end:

<i>'IS No.</i>	<i>Title</i>
IS 15388 : 2003	Specification for silica fume'

Amend No. 2 to IS 456 : 2000

(Page 80, B-2.1.1, informal table) — Insert the following in the table:

M55
5.6

(Page 81, Table 21) — Insert the following row after the last row:

(1)	(2)	(3)	(4)
M55	17.5	13.0	1.5'

(Page 91, Table 26, Case No. 2, col 2) — Substitute 'One Short Edge Discontinuous' for 'One Short Edge Continuous'.

[Page 96, G-1.1(c), formula] — Substitute ' $M_{u,lim}$ ' for ' M_u^{lim} '.

[Page 96, G-1.1(d), last line] — Substitute '38.1' for '39.1'.

(CED 2)

AMENDMENT NO. 3 AUGUST 2007
TO
IS 456 : 2000 PLAIN AND REINFORCED
CONCRETE — CODE OF PRACTICE

(Fourth Revision)

(Page 2, Foreword) — Insert the following after para 8:

‘The provisions for Self Compacting Concrete have been included for guidance (see Annex J).’

(Page 10) — Add the following at the end:

‘ANNEX J SELF COMPACTING CONCRETE’

(Page 15, clause 5.4.4, last sentence) — Delete.

(Page 15, clause 5.6.2) — Add the following at the end:

‘Reduction in design bond strength of coated bars shall be looked into.’

(Page 15, clause 5.6.3) — Add the following after the clause and renumber the existing clause ‘5.7’ as ‘5.8’.

‘5.7 Fibres

Fibres may be added to concrete for special applications to enhance properties, for which specialist literature may be referred to.’

(Page 15, clause 6.1.3) — Substitute the following for the existing clause:

‘Concrete of grades lower than those given in Table 5 may be used for lean concrete, foundation for masonry walls or temporary reinforced concrete construction.’

[Page 17, clause 7.1 (see also Amendment No. 1)] — In the informal table, delete the words ‘In-situ piling’ in column 1.

Amend No. 3 to IS 456 : 2000

(Page 23, Table 9) — Number the existing note as 'NOTE 1' and add the following 'NOTE 2':

'NOTE 2 — Quantity of water required from durability point of view may be less than the value given above.'

(Page 29, clause 15.1.1, last line) — Add 'in accordance with 16' at the end.

(Page 30, Table 11, col 2) — Substitute ' $f_{ck} + 3 \text{ N/mm}^2$ ' for ' $f_{ck} + 4 \text{ N/mm}^2$ ' against 'M 20 or above'.

(Page 30, Table 11, col 3 (see also Amendment No. 1)) — Substitute ' $f_{ck} - 3 \text{ N/mm}^2$ ' for ' $f_{ck} - 4 \text{ N/mm}^2$ ' against 'M 20 or above'.

(Page 42, clause 26.1.1) — Add the following at the end:

'Congestion of reinforcement should be avoided during detailing. Various methods such as choosing the diameter and grade of steel carefully and bundling of reinforcement, if required, are available.'

[Page 45, clause 26.2.5.1(a)] — Substitute the following for the existing:

'Lap splices shall not be used for bars larger than 32 mm. Bars larger than 32 mm shall be welded (see 12.4) or mechanically spliced.'

[Page 46, clause 26.3.3(b)(2), last line] — Substitute '300 mm' for '450 mm'.

[Page 47, clause 26.5.1.1(b)] — Add the following note at the end:

'NOTE — The use of 4 percent reinforcement may involve practical difficulty in placing and compacting concrete; hence lower percentage is recommended.'

(Page 47, clause 26.5.1.2) — Add the following note at the end:

'NOTE — The use of 4 percent reinforcement may involve practical difficulty in placing and compacting of concrete; hence lower percentage is recommended.'

(Page 52, clause 29.3.4, last line) — Substitute '32.5' for '32.4'.

(Page 100, Annex H) — Add the following annex:

ANNEX J

(Foreword)

SELF COMPACTING CONCRETE

J-1 GENERAL

Self compacting concrete is a concrete that fills uniformly and completely every corner of formwork by its own weight without application of any vibration, without segregation, whilst maintaining homogeneity.

J-2 APPLICATION AREA

Self compacting concrete may be used in precast concrete applications or for concrete placed on site. It may be manufactured in a site batching plant or in a ready-mixed concrete plant and delivered to site by truck mixer. It may then be placed either by pumping or pouring into horizontal or vertical forms.

J-3 FEATURES OF FRESH SELF COMPACTING CONCRETE

The following are some of the features of self compacting concrete:

- a) Slump flow: 600 mm, *Min.*
- b) Sufficient amount of fines (< 0.125 mm) preferably in the range of 400 kg/m³ to 600 kg/m³. This can be achieved by having sand content more than 38 percent and using mineral admixture to the order of 25 percent to 50 percent by mass of cementitious materials.
- c) Use of high range water reducing (HRWR) admixture and viscosity modifying agent (VMA) in appropriate dosages.

(CED 2)

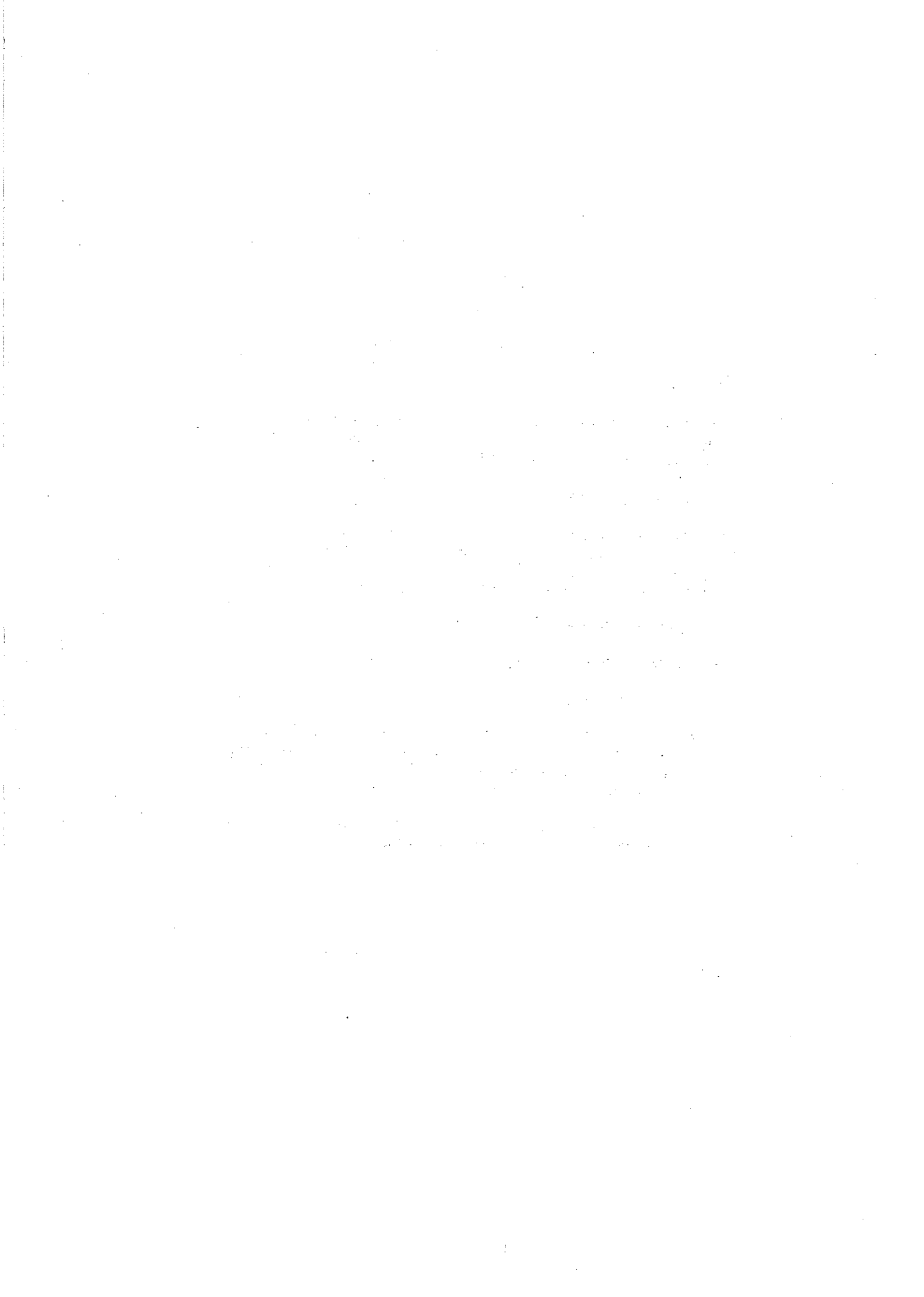

AMENDMENT NO. 4 MAY 2013
TO
IS 456 : 2000 PLAIN AND REINFORCED CONCRETE — CODE OF PRACTICE

(Fourth Revision)

(Page 14, clause 5.3, second sentence) — Delete.

(Page 14, clause 5.3.4, second sentence) — Delete.

(Page 14, clause 5.4, line 1) — Substitute 'Water, natural or treated,' for 'Water'.

(Page 14, clause 5.4.3, first sentence) — Substitute the following for the existing sentence:

'Sea water shall not be used for mixing or curing of concrete because of presence of harmful salts.'

(Page 15, clause 5.5.6) — Insert the following new clause:

'5.5.7 The amount of admixture added to a mix shall be recorded in the production record. Redosing of admixtures is not normally permitted. In special circumstances, if necessary, additional dose of admixture may be added at project site and mixed adequately in mixer itself to regain the workability of concrete with the mutual agreement between the producer/supplier and the purchaser/user of concrete. However, the producer/supplier shall assure the ultimate quality of concrete supplied by him and maintain record of quantity and time of addition.'

(Page 16, Table 2) — Substitute the following table for the existing table:

Table 2 Grades of Concrete
(Clauses 6.1, 9.2.2, 15.1.1 and 36.1)

Group	Grade Designation	Specified Characteristic Compressive Strength of 150 mm Cube at 28 days N/mm ²
(1)	(2)	(3)
Ordinary Concrete	M 10	10
	M 15	15
	M 20	20
Standard Concrete	M 25	25
	M 30	30
	M 35	35
	M 40	40
	M 45	45
	M 50	50
	M 55	55
	M 60	60
High Strength Concrete	M 65	65
	M 70	70
	M 75	75
	M 80	80
	M 85	85
	M 90	90
	M 95	95
	M 100	100

NOTES

1 In the designation of concrete mix M refers to the mix and the number to the specified characteristic compressive strength of 150 mm size cube at 28 days, expressed, in N/mm².

2 For concrete of grades above M 60, design parameters given in the standard may not be applicable and the values may be obtained from specialized literatures and experimental results.

Amendment No. 4 to IS 456 : 2000

(Page 17, clause 8.1, line 3) — Insert the word 'life' after 'service'.

(Page 20, Table 5, Note 1) — Substitute the following for the existing note:

'1 Cement content prescribed in this table is irrespective of grades and types of cement and is inclusive of mineral admixtures mentioned in 5.2. The mineral admixtures such as fly ash or ground granulated blast furnace slag shall be taken into account in the concrete composition with respect to the cement content and water-cement ratio not exceeding the limit of fly ash and slag specified in IS 1489 (Part 1) and IS 455 respectively, beyond which these additions, though permitted, shall not be considered for these purposes.'

(Page 20, Table 5, Note 2) — Insert the following new note:

'3 The minimum cement content, maximum free water-cement ratio and minimum grade of concrete are individually related to exposure.'

[Page 21, clause 8.2.5.4 (b), para 2] — Substitute 'fly ash conforming to IS 3812 (Part 1) or ground granulated' for 'fly ash (Grade 1) conforming to IS 3812 or granulated' and '25 percent' for '20 percent'.

(Page 21, clause 8.2.6.2, para 2) — Substitute the following for the existing para:

'Additional protection may be obtained by the use of suitable impermeable barriers.'

(Page 22, clause 9.2.1) — Insert the following at the end:

'If so desired, the employer shall be provided with supporting data including graphs showing strength *versus* water-cement ratio for range of proportions, complete trial mix proportioning details to substantiate the choice of cement content, fine and coarse aggregate content, water, mineral admixtures, chemical admixtures, etc.'

(Page 22, clause 9.2.2, first sentence) — Insert the following after first sentence:

'Proportion/grading of aggregates shall be made by trial in such a way as to make densest possible concrete.'

(Page 23, Table 8) — Substitute the following for the existing table:

Table 8 Assumed Standard Deviation
(Clause 9.2.4.2 and Table 11)

Grade of Concrete	Assumed Standard Deviation N/mm ²
M 10 } M 15 }	3.5
M 20 } M 25 }	4.0
M 30 } M 35 } M 40 } M 45 } M 50 } M 55 } M 60 }	5.0

NOTES

1 The above values correspond to the site control having proper storage of cement; weigh batching of all materials; controlled addition of water; regular checking of all materials, aggregate grading and moisture content; and periodical checking of workability and strength. Where there is deviation from the above, the values given in the above table shall be increased by 1 N/mm².

2 For grades above M 60, the standard deviation shall be established by actual trials based on assumed proportions, before finalizing the mix.

(Page 24, clause 10.2, para 2) — Substitute the following for the existing para:

‘For large and medium project sites, the concrete shall be sourced from ready-mixed concrete plants or from captive on-site or off-site automatic batching and mixing plants. The concrete produced and supplied by ready-mixed concrete plants shall be in accordance with IS 4926. In case of concrete from captive on-site or off-site automatic batching and mixing plants, similar quality control shall be followed.’

(Page 24, clause 10.2.1, first sentence) — Substitute the following for the existing sentence:

‘The grading of aggregate shall be controlled by obtaining the coarse aggregate in different sizes and blending them in right proportions, the different sizes being stocked in separate stock-piles.’

(Page 24, clause 10.2.2) — Substitute the following for the existing clause:

‘10.2.2 The accuracy of the measuring equipment shall be within ± 2 percent of the quantity of cement and mineral admixtures being measured and within ± 3 percent of the quantity of aggregate, chemical admixtures and water being measured. In a batching plant, the concrete production equipment shall be calibrated initially at the time of installation or reconditioning of the equipment and subsequently at the following intervals:

- a) Mechanical/ knife edge systems : At least once every two months
- b) Electrical/ load cell systems : At least once every three months’.

(Page 24, clause 10.2.3) — Substitute the following for the existing clause:

‘10.2.3 All ingredients of concrete shall be used by mass except water and chemical admixtures, which may be by volume.’

(Page 24, clause 10.2.5, fourth sentence) — Insert the following after fourth sentence:

‘Where batching plants are used, it is recommended to determine moisture content by moisture probes fitted to the batching plants.’

(Page 24, clause 10.3, first and second sentence) — Substitute the following for the existing sentences:

‘Concrete shall be mixed in a mechanical mixer (*see also* IS 1791 and IS 12119). It shall be ensured that stationary or central mixers and truck mixers shall comply with the performance criteria of mixing efficiency as per IS 4634. Mixing efficiency test shall be performed at least once in a year.’

(Page 25, clause 10.3.1) — Substitute the following for the existing clause:

‘10.3.1 As a guidance, the mixing time shall be at least 2 min for conventional free fall (drum) batch type concrete mixers. For other types of more efficient mixers, manufacturers’ recommendations shall be followed.’

(Page 25, clause 10.3.3) — Substitute the following for the existing clause:

‘10.3.3 Dosages of retarders, plasticizers and superplasticizers shall be restricted to 0.5, 1.0 and 2.0 percent respectively by mass of cementitious materials; however, the dosages of polycarboxylate based admixtures shall not exceed 1.0 percent. A higher value of above admixtures may be used, if agreed upon between the manufacturer and the constructor based on performance tests relating to workability, setting time and early age strength.’

(Page 25, clause 11.1, informal table) — Substitute the following for the existing table:

a) Deviation from specified dimensions of cross-section of columns and beams	+10 -5 mm
b) Deviation from dimensions of footings:	
1) Dimensions in plan	+50 -10 mm
2) Eccentricity	0.02 times the width of the footing in the direction of deviation but not more than 50 mm
3) Thickness	+50 -10 mm or ± 0.05 times the specified thickness, whichever is less

(Page 27, clause 13.4, para 1, fourth sentence) — Delete.

[Page 30, Table 11 (see also Amendments No. 1 and 3)] — Substitute the following for the existing Table 11:

Table 11 Characteristic Compressive Strength Compliance Requirement
(Clauses 16.1 and 16.3)

Specified Grade	Mean of the Group of 4 Non-Overlapping Consecutive Test Results in N/mm^2 <i>Min</i>	Individual Test Results in N/mm^2 <i>Min</i>
(1)	(2)	(3)
M 15 and above	$\geq f_{ck} + 0.825 \times$ established standard deviation (rounded off to nearest $0.5 N/mm^2$) or $f_{ck} + 3 N/mm^2$, whichever is greater	$\geq f_{ck} - 3 N/mm^2$

NOTES

1. In the absence of established value of standard deviation, the values given in Table 8 may be assumed, and attempt should be made to obtain results of 30 samples as early as possible to establish the value of standard deviation.

2. For concrete of quantity up to $30 m^3$ (where the number of samples to be taken is less than four as per the frequency of sampling given in 15.2.2), the mean of test results of all such samples shall be $f_{ck} + 4 N/mm^2$, minimum and the requirement of minimum individual test results shall be $f_{ck} - 2 N/mm^2$, minimum. However, when the number of sample is only one as per 15.2.2, the requirement shall be $f_{ck} + 4 N/mm^2$, minimum.

[Page 41, clause 24.4.1 (a)] — Substitute the following for the existing:

'a) Calculate the sum of the midspan moment and the average of the support moments (neglecting signs) for each panel.'

(Page 42, clause 26.2.1, Note 2) — Insert the following new note:

'3 For plain cement concrete of M15 grade with nominal reinforcement, the design bond stress may be taken as $1.0 N/mm^2$.'

(Page 43, clause 26.2.1.1, para 2) — Insert the following at the end of para:

‘For fusion bonded epoxy coated deformed bars, design bond stress values shall be taken as 80 percent of the values given in the above table.’

(Page 67, clause 35.3.2, last para, third sentence) — Substitute the following for the existing sentence:

‘For particularly aggressive environment, such as ‘very severe’ and ‘extreme’ categories given in Table 3, the assessed surface width of cracks should not in general, exceed 0.1 mm.’

(Page 74, clause 40.5.2, formula) — Substitute, ‘ ΣA_{sv} ’ for ‘ A_s ’ in the formula.

[Page 80, clause B-2.1.1, informal table (see also Amendment No. 2)] — Substitute

M 50 and above	for	M 50 M 55
5.2		5.2 5.6

[Page 81, Table 21 (see also Amendment No.2)] — Substitute the entries against M 55 and insert new row for M 60, as follows:

Grade of Concrete	Permissible Stress in Compression		Permissible Stress in Bond (Average) for Plain Bars in Tension
	Bending	Direct	
(1)	(2)	(3)	(4)
M 55	18.0	13.5	1.5
M 60	20.0	15.0	1.6

(Page 92, clause E-1, line 5) — Substitute ‘Fig. 27’ for ‘Fig. 26’.

AMENDMENT NO. 5 JULY 2019
TO
IS 456 : 2000 PLAIN AND REINFORCED CONCRETE —
CODE OF PRACTICE

(Fourth Revision)

[Page 13, *clause 5.1* (a)] — Substitute the following for the existing:

‘a) Ordinary Portland Cement conforming to IS 269’

[Page 13, *clause 5.1* (b) and (c)] — Delete.

(Page 13, *clause 5.2*) — Insert the following after the title:

‘Mineral admixtures listed below may be used along with ordinary Portland cement. Uniform blending of the mineral admixtures with the cement should be ensured.’

(Page 13, *clause 5.2.1*) — Substitute the following for the existing clause:

‘5.2.1 Pozzolanas

Pozzolanic materials, as given below, may be used.’

(Page 13, *clause 5.2.1.1, line 3*) — Delete the following:

‘provided uniform blending with cement is ensured’

[Page 13, *clause 5.2.1.2 (see also Amendment No. 2)*] — Delete the following:

‘provided uniform blending with the cement is ensured’

(Page 13, *clause 5.2.1.4*) — Substitute the following for the existing clause:

Price Group 2

Amendment No. 5 to IS 456 : 2000

‘5.2.1.4 Metakaolin

Metakaolin conforming to IS 16354 may be used as part replacement of ordinary Portland cement.’

(Page 13, clause 5.2.2) — Substitute the following for the existing clause:

‘5.2.2 Ground Granulated Blast Furnace Slag

Ground granulated blast furnace slag conforming to IS 16714 may be used as part replacement of ordinary Portland cement.’

(Page 14, clause 5.2.2) — Insert the following new clause:

‘5.2.3 Precautions

5.2.3.1 For concrete made with mineral admixtures, the setting time and rate of gain of strength may be different from those of concrete made with ordinary Portland cement alone. Cognizance of such modified properties shall be taken into account in deciding de-shuttering time, rate of movement of formwork in slipform construction, initial time of prestressing, longer curing period and for early age loading. The compatibility of chemical admixtures and cementitious materials should be ensured by trials.

5.2.3.2 Concrete containing mineral admixtures may exhibit an increase in plastic shrinkage cracking because of its low bleeding characteristics. The problem may be avoided by ensuring that such concrete is protected against drying, both during and after finishing.

5.2.3.3 Some other properties of concrete such as modulus of elasticity, tensile strength, creep and shrinkage are not likely to be significantly different. For design purposes, it will be sufficiently accurate to adopt the same values as those used for concrete made with ordinary Portland cement alone.

5.2.3.4 Mixes that contain very fine mineral admixtures such as silica fume, can be sticky and difficult to finish.

5.2.3.5 Concrete made using blended cements such as Portland pozzolana cement and Portland slag cement shall also adhere to **5.2.3.1, 5.2.3.2** and **5.2.3.3.**’

Amendment No. 5 to IS 456 : 2000

(Page 14, clause 5.3, line 1) — Insert, ‘derived from natural sources and from other than natural sources,’ after ‘Aggregates’.

(Page 17, clause 8.1.1, para 3, first sentence) — Insert the following after first sentence:

‘Maintenance plays an important role in sustained durability of concrete (see also 10.1).’

(Page 19, Table 4, Note 4) — Substitute the following for the existing:

‘4 The cement contents given in col 7 of this table are the minimum recommended. For SO₃ contents near the upper limit of any class, cement contents above these minimum are advised. For the purpose of calculation of SO₃ content (if the test results are in the form of SO₄, the following relation shall be used: SO₃ = 0.833 SO₄.’

(Page 20, clause 8.2.5.3, line 6) — Insert ‘(where SO₃ = 0.833 SO₄)’ after ‘SO₃’.

[Page 20, clause 8.2.5.4, para 2, (b)] — Substitute the following for the existing:

- ‘b) Use of low alkali ordinary Portland cement having total alkali content not more than 0.6 percent [as Na₂O equivalent (expressed as Na₂O + 0.658 K₂O)].

Further advantage can be obtained by use of fly ash conforming to IS 3812 (Part 1) or ground granulated blast furnace slag conforming to IS 16714 as part replacement of ordinary Portland cement [having total alkali content as Na₂O equivalent (expressed as Na₂O + 0.658 K₂O) not more than 0.6 percent], provided fly ash content is at least 25 percent or slag content is at least 50 percent.’

(Page 25, clause 11.3.1, line 4) — Delete the following:

‘and where ordinary Portland cement is used and adequate curing is done’

Amendment No. 5 to IS 456 : 2000

(Page 25, clause 11.3.1, informal table) — Substitute the following for the existing table:

Sl No.	Type of Formwork	Minimum Period Before Striking Formwork	
		For Concrete Made Using OPC	For Concrete Made Using Cement Other than OPC or Using Mineral Admixtures Like Fly Ash and Slag
(1)	(2)	(3)	(4)
i)	Vertical formwork to columns, walls, beams	16-24 h	16-24 h
ii)	Soffit formwork to slabs (Props to be refixed immediately after removal of formwork)	3 days	7 days
iii)	Soffit formwork to beams (Props to be refixed immediately after removal of formwork)	7 days	10 days
iv)	Props to slabs: 1) Spanning up to 4.5 m 2) Spanning over 4.5 m	7 days 14 days	10 days 14 days
v)	Props to beams and arches: 1) Spanning up to 6 m 2) Spanning over 6 m	14 days 21 days	14 days 21 days
NOTE — Utmost care shall be taken to provide props. The props shall be provided immediately after stripping each shuttering panel and not after stripping all the panels of the entire slab.			

(Page 25, clause 11.3.1, last sentence) — Delete the words ‘other cements and’.

(Page 25, clause 11.3.1) — Insert the following new clause:

11.3.1.1 In case of use of cements other than OPC or in case of use of mineral admixtures like fly ash and slag, *in lieu* of the minimum period specified in 11.3.1 col 3, the stripping of formwork may be done in accordance with the provisions of 11.3.1 col 2, provided concrete cube testing is done to ensure that the following minimum strength is achieved:

Amendment No. 5 to IS 456 : 2000

- a) 3 days : 45 percent of specified strength
- b) 7 days : 60 percent of specified strength
- c) 14 days : 85 percent of specified strength

(Page 26, clause **13.3.1**, sentence one) — Substitute the following for the existing:

‘Concrete shall be compacted using mechanical vibrators complying with IS 2505, IS 2506 and IS 2514.’

(Page 33, clause **21.1**, sentence four) — Substitute the following for the existing sentence:

‘Essential requirements of fire safety of buildings with respect to details of construction are given in IS 1642.’

[Page 45, clause **26.2.5.1** (g)] — Insert the following para at the end:

‘Reinforcement couplers for mechanical splices of bars for concrete reinforcement, used, shall be in accordance with IS 16172.’

(Page 72, clause **40.2.3.1**) — Substitute the following for the existing:

40.2.3.1 For solid slabs, the nominal shear stress shall not exceed half the appropriate values given in Table 20.

Maximum shear stress, $\tau_{c \max}$ given in Table 20 is valid for all load cases including earthquake except the following:

- a) For coupling beams in coupled shear walls, under earthquake forces, the limiting value of $\tau_{c \max}$ given in Table 20 shall be superseded by **10** of IS 13920 : 2016.
- b) Coupled shear walls shall be connected by ductile coupling beams. If the earthquake induced shear stress in the coupling beam exceeds,

$$\frac{0.1\ell_s\sqrt{f_{ck}}}{D}$$

Amendment No. 5 to IS 456 : 2000

where ℓ_s is the clear span of the coupling beam and D is its overall depth, the entire earth quake induced shear and flexure shall, preferably, be resisted by diagonal reinforcement.

The area of reinforcement to be provided along each diagonal in a diagonally reinforced coupling beam shall be,

$$A_{sd} = \frac{V_u}{1.74f_y \sin \alpha}$$

where V_u is the factored shear force and α is the angle made by the diagonal reinforcement with the horizontal. At least 4 bars of 8mm diameter shall be provided along each diagonal. The reinforcement along each diagonal shall be enclosed by special confining reinforcement, as per 8 of IS 13920 : 2016. The pitch of spiral or spacing of ties shall not exceed 100 mm.

The diagonal or horizontal bars of a coupling beam shall be anchored in the adjacent walls with an anchorage length of 1.5 times the development length in tension.'

(Page 77, Annex A) — Substitute the following for the existing entries against concerned Indian Standards:

<i>IS No.</i>	<i>Title</i>
269 : 2015	Ordinary Portland cement — Specification (<i>sixth revision</i>)
383 : 2016	Coarse and fine aggregate for concrete — Specification (<i>third revision</i>)
455 : 2015	Portland slag cement — Specification (<i>fifth revision</i>)
875 (Part 3) : 2015	Wind loads (<i>third revision</i>)
1489	Portland Pozzolana cement — Specification
(Part 1) : 2015	Fly ash based (<i>fourth revision</i>)
(Part 2) : 2015	Calcined clay based (<i>fourth revision</i>)
1641 : 2013	Code of Practice for fire safety of buildings (general) : General principles of fire grading and classification (<i>second revision</i>)

Amendment No. 5 to IS 456 : 2000

<i>IS No.</i>	<i>Title</i>
1642 : 2013	Fire safety of buildings (general) : Details of construction — Code of Practice (<i>second revision</i>)
1786 : 2008	High strength deformed steel bars and wires for concrete reinforcement — Specification (<i>fourth revision</i>)
3812 (Part 1) : 2013	Pulverized fuel ash: Part 1 For use as pozzolana in cement, cement mortar and concrete (<i>third revision</i>)
6006 : 2014	Uncoated stress relieved strand for Prestressed concrete — Specification (<i>second revision</i>)
13920 : 2016	Ductile design and detailing of reinforced concrete structures subjected to seismic forces — Code of Practice (<i>first revision</i>)
14268 : 2017	Uncoated stress relieved low relaxation seven-wire (Ply) strand for prestressed concrete — Specification (<i>first revision</i>)'

[Page 78, Annex A, entries pertaining to 'IS 4656 : 1968', 'IS 8112 : 1989', 'IS 12089 : 1987' and 'IS 12269 : 1987'] — Delete.

(Page 79, Annex A) — Insert the following new entries at the end:

<i>'IS No.</i>	<i>Title</i>
16172 : 2014	Reinforcement couplers for mechanical splices of bars for concrete reinforcement — Specification
16354 : 2015	Metakaolin for use in cement, cement mortar and concrete — Specification
16714 : 2018	Ground granulated blast furnace slag for use in cement, mortar and concrete — Specification'